

PARTSLIST

PRIDE IN QUALITY



MODEL GX-221



MODEL GX-225D

STEREO TAPE DECK

MODEL GX-225D

ALSO APPLICABLE TO MODEL GX-221 STEREO TAPE
RECORDER AND GX-221D STEREO TAPE DECK

SECTION 1	SERVICE MANUAL	3
SECTION 2	PARTS LIST	29
SECTION 3	SCHEMATIC DIAGRAM	60

SECTION 1

SERVICE MANUAL

TABLE OF CONTENTS

I.	SPECIFICATIONS	4
II.	MEASURING METHOD	6
	1. TAPE SPEED DEVIATION	6
	2. WOW AND FLUTTER	6
	3. FREQUENCY RESPONSE	6
	4. SIGNAL TO NOISE RATIO	6
	5. TOTAL HARMONIC DISTORTION FACTOR	7
	6. CROSS TALK (Cross talk between the channels)	7
	7. ERASE RATIO	7
	8. POWER OUTPUT	7
III.	DISMANTLING OF UNIT	8
IV.	TRANSPORT MECHANISM	10
	1. FORWARD PLAYBACK RECORDING MODE	11
	2. FAST FORWARD/REWIND MODE	11
	3. BLOCK DIAGRAM OF VOLTAGE SUPPLY CIRCUIT TO MOTOR AT EACH MODE	11
	4. SYSTEM CONTROL CIRCUIT OPERATION	13
V.	MECHANISM ADJUSTMENTS	14
	1. REEL TABLE HEIGHT ADJUSTMENT	14
	2. PINCH WHEEL PRESSURE MEASURING METHOD	14
	3. BRAKE TENSION ADJUSTMENT	15
	4. SUPPLY VOLTAGE AND TENSION AT VARIOUS OPERATING MODES	15
VI.	HEAD ADJUSTMENTS	16
	1. HEAD HEIGHT ADJUSTMENT	16
	2. HEAD AZIMUTH ALIGNMENT ADJUSTMENT	17
VII.	AMPLIFIER ADJUSTMENTS	18
	1. PLAYBACK OUTPUT LEVEL ADJUSTMENT	18
	2. VU METER SENSITIVITY ADJUSTMENT	18
	3. HIGH RANGE VARIATION CHECK	18
	4. RECORDING LEVEL ADJUSTMENT	21
	5. RECORDING BIAS FREQUENCY MEASURING METHOD	21
	6. RECORDING BIAS VOLTAGE ADJUSTMENT (Frequency Response Adjustment)	21
VIII.	AUTOMATIC NOISE REDUCTION AMPLIFIER ADJUSTMENTS (GX-225D)	22
	1. A.N.R. AMP. ADJUSTMENT	22
	2. A.N.R. OPERATION AND CHARACTERISTICS	23
IX.	COMPOSITE VIEWS OF COMPONENTS	24

I. SPECIFICATIONS

An asterisk next to a figure indicates the minimum guaranteed performance.

TRACK SYSTEM	4 track 2 channel stereo/monaural system	
REEL CAPACITY	Up to 7" reel	
TAPE SPEED	7-1/2 ips (19 cm/sec.) $\pm 0.7\%$ (* $\pm 0.8\%$) 3-3/4 ips (9.5 cm/sec.) $\pm 0.7\%$ (* $\pm 0.8\%$) 1-7/8 ips (4.75 cm/sec.) $\pm 0.7\%$ (* $\pm 0.8\%$)	
WOW AND FLUTTER	Less than 0.08% (*0.12%) R.M.S. at 7-1/2 ips Less than 0.12% (*0.25%) R.M.S. at 3-3/4 ips Less than 0.20% (*0.4%) R.M.S. at 1-7/8 ips	
FREQUENCY RESPONSE	AKAI S.R.T. Tape	30 to 25,000 Hz ± 3 dB at 7-1/2 ips 30 to 20,000 Hz ± 3 dB at 3-3/4 ips 30 to 10,000 Hz ± 3 dB at 1-7/8 ips
	Regular Tape	30 to 23,000 Hz (*30 to 22,000 Hz) ± 3 dB at 7-1/2 ips 30 to 19,000 Hz (*30 to 18,000 Hz) ± 3 dB at 3-3/4 ips 30 to 9,000 Hz (*40 to 9,000 Hz) ± 3 dB at 1-7/8 ips
SIGNAL TO NOISE RATIO	Better than 50 dB (53 dB with N.R. process) * Better than 48 dB at 7-1/2 ips * Better than 47 dB at 3-3/4 ips * Better than 45 dB at 1-7/8 ips * Better than 44 dB at Reverse Mode	
HUM AND NOISE	5 mV Tone Control and Main Volume: Min. (Model GX-221 only)	
DISTORTION FACTOR	Less than 1.5% (*3%) at 1,000 Hz "0" VU Recording	
TONE CONTROLS	Treble	12 ± 2 dB (Max.) and -14 ± 2 dB (Min.) at 10 kHz
	Bass	12 ± 2 dB (Max.) and -10 ± 2 dB (Min.) at 100 Hz (Model GX-221 only)
CROSS TALK	Better than 65 dB (*58 dB) monaural Better than 50 dB (*43 dB) stereo	
ERASE RATIO	Better than 70 dB	
BIAS FREQUENCY	100 kHz $\pm 5\%$	
BIAS LEAK	Less than -20 VU	
HIGH FREQUENCY DEVIATION	Between Channels	Within 2 dB, using an 8,000 Hz 3-3/4 ips recorded tape at 7-1/2 ips
	Between FWD/REV	Within 3 dB, using an 8,000 Hz 3-3/4 ips recorded tape at 7-1/2 ips
REC./P.B. LEVEL	4 ± 1.5 dB	
INPUTS	Mic Input	0.2 mV (*0.4 mV) Impedance: 10 k Ω
	Line Input	50 mV (*60 mV) Impedance: 150 k Ω
	Din Input	2 mV (low) and 50 mV (*60 mV) (high)
OUTPUTS	Line Output	1.228V (4 ± 1 dB) Impedance: 20 k Ω
	Din Output	0.4V
	Speaker Output	30 W total music power at 8 Ω (GX-221 only) 20 W continuous power at 8 Ω (GX-221 only)
HEAD PHONE OUTPUT	30 to 40 mV at 8 Ω	
REVERSING TIME	2 to 6 sec.	
FAST FORWARD AND REWIND TIME	85/65 sec., using a 1,200 ft. tape at 50/60 Hz	
MOTORS	Main Motor	3 speed hysteresis synchronous motor Type: HC-16X Revolutions: 3,000/1,500/750 r.p.m. (50 Hz) 3,600/1,800/900 r.p.m. (60 Hz)
	Reel Motor	Two 6-pole eddy current outer rotor motors Type: 24XO-MR Revolutions: 930 r.p.m. (50 Hz) 1,120 r.p.m. (60 Hz)
HEADS	Erase Head	Type: E4-250 Gap: 0.6 mm Impedance: 195 Ω $\pm 10\%$ at 100 kHz D.C. Resistance: 3.5 Ω

	Recording Head	Type: R4-200 Gap: $4\mu \pm 15\%$ Impedance: 1.870Ω at 100 kHz D.C. Resistance: 8Ω	
	Playback Head	Type: P4-200 Gap: $1.75\mu \pm 15\%$ Impedance: $3 \pm 1\text{ k}\Omega$ at 1 kHz D.C. Resistance: 500Ω	
	I.C.	LD3141 ... 2	STR015 ... 2(GX-221 only)
	TRANSISTORS	2SC372(Y) ... 1 2SC871(F) ... 12 2SC945(Q)(R) ... 6 2SC968(3)(4) ... 3 2SC458LG(C) ... 6 (N.R. Amp.)	2SC971(2)(3) RED ... 2 2SC1211(C)(D) ... 1 2SD223(G)(Y) ... 1 2SC711(E) ... 4 (N.R. Amp.)
	DIODES	1N34A ... 7 10D1 ... 3 10D4 ... 1 WG-599 ... 4(N.R. Amp.)	5B2 ... 1(GX-221 only) WZ-340 ... 1
	POWER SUPPLY	100 to 240 V A.C. 50/60 Hz	
	POWER CONSUMPTION	90W Models GX-225D, GX-221D 135W Model GX-221	
	INSULATION RESISTANCE	More than 50 M Ω	
	INSULATION DURABILITY	500V D.C. for more than 1 min. duration.	
	DIMENSIONS	430(W) x 425(H) x 230(D) mm (17.2" x 17" x 9.2")	
	WEIGHT	20.5 kg(45.1 lbs.) Models GX-225D, GX-221D 22.5 kg(49.5 lbs.) Model GX-221	

NOTE: Specifications subject to change without notice.

II. MEASURING METHOD

1. TAPE SPEED DEVIATION

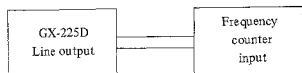

Fig. 1

As shown in Fig. 1, connect a Frequency Counter to the Line output. Playback a 1,000 Hz pre-recorded test tape. Take a frequency counter reading at the beginning, middle, and end of tape winding during playback. The maximum value of these respective readings will represent tape speed deviation.

2. WOW AND FLUTTER

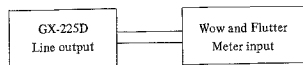

Fig. 2

Method A

As shown in Fig. 2, connect the Line output to the input of a Wow and Flutter Meter. Playback a 3,000 Hz pre-recorded test tape and take a wow and flutter meter reading at the beginning, middle, and end of tape winding. The maximum value of these respective readings will represent the wow and flutter.

Method B

Supply a 3,000 Hz sine wave signal from an Audio Frequency Oscillator and make a recording on a blank tape at the beginning, middle, and end of tape winding. Rewind and playback the resultant signal. Measure wow and flutter with a Wow and Flutter Meter. (The wow and flutter value of Method B will be close to twice that of Method A.)

3. FREQUENCY RESPONSE

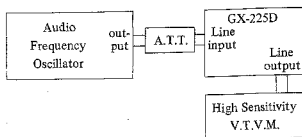

Fig. 3

For measuring frequency response, connect instruments as shown in Fig. 3 and proceed as follows:

- 1) Supply a 1,000 Hz sine wave to the Line input from an Audio Frequency Oscillator through an Attenuator.
- 2) Set recorder to recording mode and turn recording level control volume and line output level control volume to maximum. Adjust attenuator to obtain a +4 dB V.T.V.M. reading.
- 3) Under conditions described in 2) above, re-adjust attenuator so that the Line Output is -16 dB, and record 30 to 22,000 Hz at 7-1/2 ips spot frequencies.
- 4) Rewind the tape and playback from the beginning. Take V.T.V.M. spot frequency readings and plot values on a graph.

NOTE: When measuring frequency response, new tape should be used.

4. SIGNAL TO NOISE RATIO



Fig. 4

As shown in Fig. 4, connect a High Sensitivity V.T.V.M. to the Line output. Playback a 250 Hz "0" VU pre-recorded test tape and measure the output. Then remove the tape and measure the noise level under the same condition. Convert each of the measured values into decibels.

5. TOTAL HARMONIC DISTORTION FACTOR

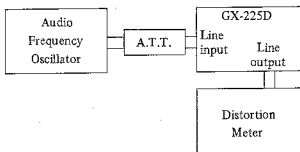

Fig. 5

Connect the measuring instruments as shown in Fig. 5 and record a 1,000 Hz sine wave signal at "0" VU. Playback the resultant signal and measure the overall distortion factor. Measure the noise level of the tape recorder without the tape. Connect the audio frequency oscillator directly to the distortion meter for measurement of the distortion factor of the oscillator. The required distortion factor can be obtained from the results of the above measurement by the following formula:

$$d_0 = d - d_1 - d_2$$

where, d_0 = Required distortion factor
 d = Overall distortion factor
 d_1 = Noise level
 d_2 = Distortion factor of the oscillator

NOTE: When measuring the distortion factor, new tape should be used.

6. CROSS TALK (Cross talk between the channels)

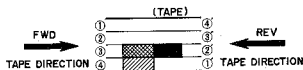

Fig. 6

As shown in Fig. 6, first record a 1,000 Hz sine wave signal on Track No. 3 at +3 VU level. Next, record under a non-input condition. Then, playback the tape on Tracks No. 3 and 4 (reversed condition of tape) through the B.P.F. (band pass filter sensitivity ... 1:1) and obtain a ratio between the two from the following formula:

$$C = 20 \log \frac{E_0}{E_2 - E_1} \text{ (dB)}$$

where, C = Desired cross talk ratio (dB)
 E_0 = 1,000 Hz signal output level (represented by solid black shading)
 E_2 = 1,000 Hz cross talk level (represented by diagonal line shading)
 E_1 = Non-input signal recorded level (represented by cross-hatch shading)

Fig. 7

7. ERASE RATIO

As shown in Fig. 4, connect a High Sensitivity V.T.V.M. to the Line output. Playback a virgin tape and take a V.T.V.M. reading of the output level. Next, record a 1,000 Hz sine wave signal at +3 VU, then playback this recorded signal and take a V.T.V.M. reading of the output level. Next, using this pre-recorded tape, record under a non-input condition and take a reading of the noise level output of the erased signal and obtain a ratio between the two from the following formula:

$$E_r = 20 \log \frac{E_0}{E_2 - E_1} \text{ (dB)}$$

where, E_r = Desired erase ratio (dB)
 E_0 = 1,000 Hz signal output level
 E_2 = Non-input signal recorded level
 E_1 = Virgin tape noise output level

8. POWER OUTPUT (GX-221 only)

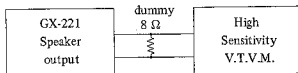

Fig. 8

As shown in Fig. 7, connect an 8Ω dummy load resistor to the speaker output and connect this terminal to a High Sensitivity V.T.V.M. Playback a 250 Hz "0" VU pre-recorded test tape and take a V.T.V.M. reading of the output level. The resultant output can be obtained from the above measurement by using the following formula:

$$P = \frac{E^2}{R} \text{ (W)}$$

where, P = Desired power output (watts)
 E = Measured voltage (R.M.S.)
 R = 8Ω

III. DISMANTLING OF UNIT

In case of trouble, etc. necessitating disassembly, please disassemble in the order shown in photographs. Reassemble in reverse order.

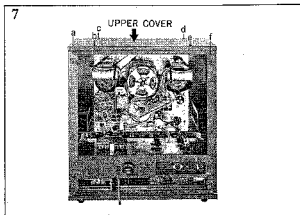
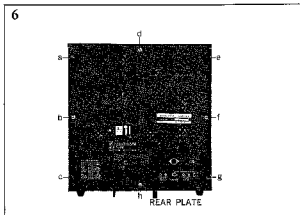
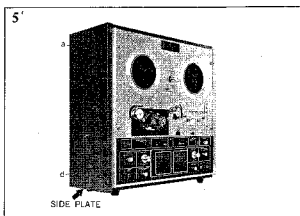
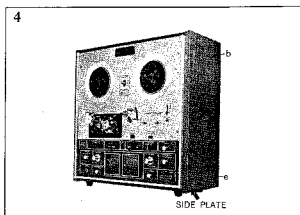
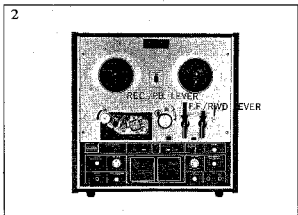
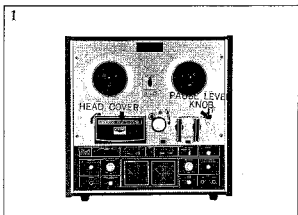

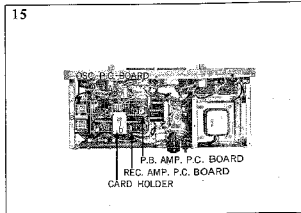
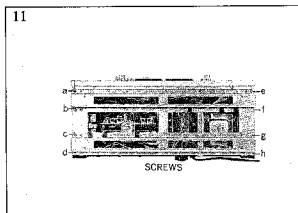
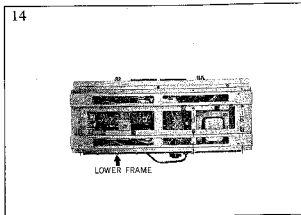
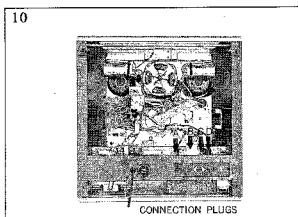
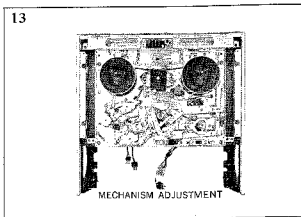
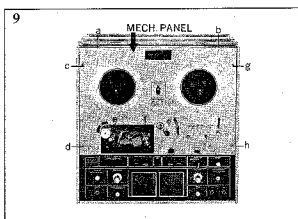
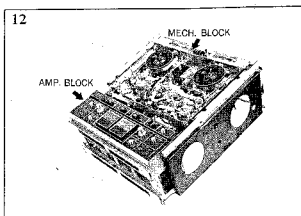
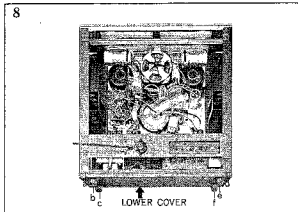

IV. TRANSPORT MECHANISM

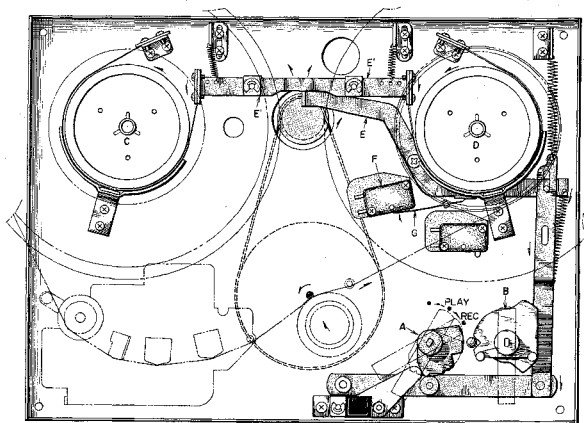

Fig. 9 FWD P.B./RECORDING REVERSE MODE

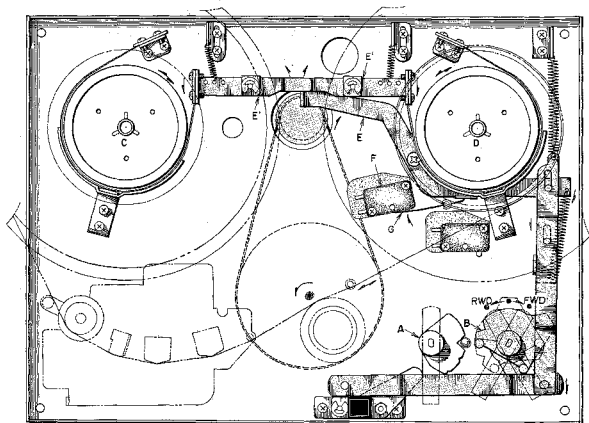

Fig. 10 F.FWD/RWD MODE

1. FORWARD PLAYBACK RECORDING MODE (Refer to Fig. 9)

Setting Recording/Playback lever (A) to playback position causes brake lever (E') to move in the direction of the arrow and release the brake of both torque motors, and at the same time, operation micro switch (SW-006) is turned ON by lever (G), and the torque motors begin to rotate in the direction of the arrows. Also the capstan contacts the pinch roller and the tape is transported at constant speed.

2. FAST FORWARD/REWIND MODE (Refer to Fig. 10)

- 1) Setting Fast Forward/Rewind lever (B) to Fast Forward or Rewind position causes brake lever (E') to move in the direction of the arrow, and release the brake of both torque motors, and at the same time, operation micro switch (SW-006) is turned ON by lever (G) and the torque motors begin to rotate in the direction of the arrows.
- 2) For fast forward or rewind, the mechanical operation is the same, but the voltage supply is different at each mode. (Refer to Chart 2)

3. BLOCK DIAGRAM OF VOLTAGE SUPPLY CIRCUIT TO MOTOR AT EACH MODE

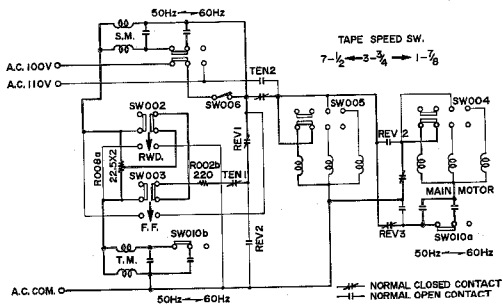

Fig. 11 NORMAL PLAYBACK MODE

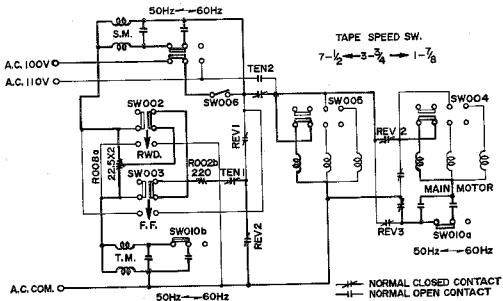

Fig. 12 REVERSE PLAYBACK MODE

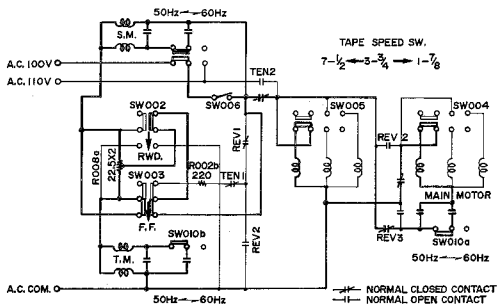

Fig. 13 F.FWD MODE

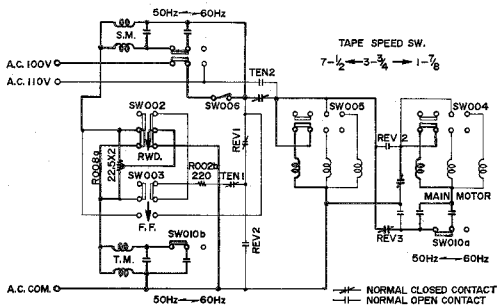
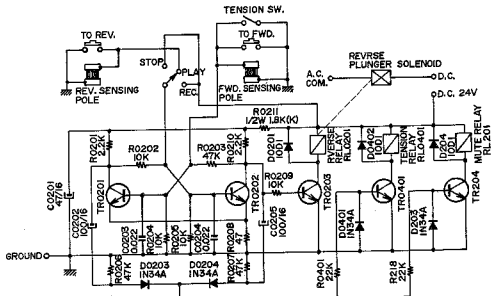

Fig. 14 RWD MODE



Schematic 1

Transistor Mode	TR0201	TR0202	TR0203	TR0401	TR204
Normal P.B.	OFF	ON	OFF	OFF	OFF
Reverse P.B.	ON	OFF	ON	ON	ON

Chart 1

4. SYSTEM CONTROL CIRCUIT OPERATION

1) Tension Relay Operation

The tension relay functions to switch the supply voltage only when the main motor is first started or at reverse time when the starting torque changes until stability is obtained. The tension relay also prevents strong tension from being applied to the tape when tape direction is changed by supplying uniform voltage to both torque motors.

2) Mute Relay Operation

Because tape travel is slow when the machine is first switched to or from Forward and Reverse, the mute relay mutes the line output signal until proper main motor revolutions are reached.

3) System Control Operation

In Schematic 1, at Forward Playback time, because transistor TR0202 base bias is high when compared with transistor TR0201, TR0202 is held at ON condition. Consequently, the collector voltage of TR0202 is low, and transistor TR0203 is OFF. Also because the condenser C0202 is charged by the collector voltage of transistor TR0201, the base bias of transistor TR0401 as well as TR204 is low and is held at OFF condition. When the Reverse Button is depressed, or the sensing tape passes the reverse sensing pole, the base of transistor TR0202 is grounded, the collector voltage of TR0202 increases and TR0203 is turned ON, and because Rev. Relay RL0201 operates, main motor reverse revolutions begin.

Also because of the TR0202 collector voltage increase, the charge current which has passed diode DO204 as well as resistors R0401 and R218 and also the internal impedance of transistors TR0401 and TR204 flows to condenser C0205, and while this current is flowing, TR0401 and TR204 is maintained at ON condition, and Tension Relay RL0401 as well as Mute Relay RL201 operates.

When the main motor begins reverse revolutions and proper tape speed is reached, the charge of condenser C0205 will be stopped, TR0401 and TR204 base bias will disappear and these two transistors are turned off, the tension relay as well as the Mute Relay is turned off, and proper reverse mode operation begins. During reverse playback when the FWD Button is depressed or the sensing tape passes the FWD sensing pole, the base of transistor TR0201 is grounded, TR0201 is turned off and the collector voltage increases.

Accordingly, transistor TR0202 base bias becomes high, TR0202 is turned ON and the collector voltage decreases. At this time, TR0203 is turned OFF, and Rev. Relay RL0201 is also turned OFF. Thus, main motor revolutions are switched to normal playback direction. Also because of the TR0201 collector voltage increase, as at reverse time, charge current flows to condenser C0202, and transistor TR0401 and TR204 are turned ON. Consequently, Tension Relay RL0401 as well as Mute Relay RL201 operates. The main motor begins forward revolutions and when proper tape speed is reached, condenser C0202 charge will be stopped, the Tension Relay as well as Mute Relay is turned OFF, and proper forward mode operation begins.

At Stop or Recording mode, voltage is supplied to TR0202 base, and because Reverse Button and sensing tape is irrelevant, main motor revolutions are always in forward playback direction.

V. MECHANISM ADJUSTMENTS

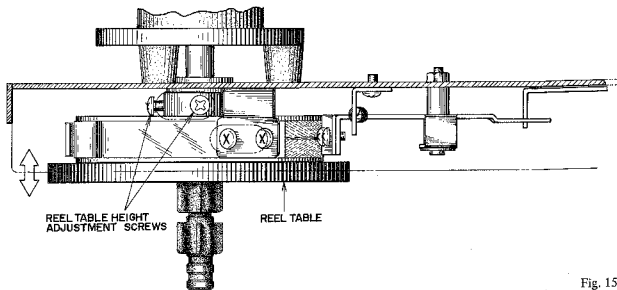

Fig. 15

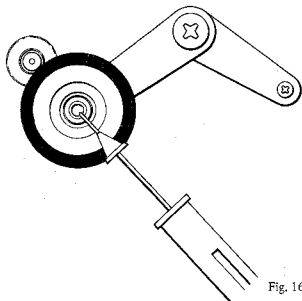

Fig. 16

1. REEL TABLE HEIGHT ADJUSTMENT

As shown in Fig. 15, loosen reel table height adjustment screws, and adjust reel table height by moving table in direction of arrow and positioning so that the tape winds in the center of the reel.

2. PINCH WHEEL PRESSURE MEASURING METHOD

Measure pinch wheel pressure with a tension gauge as shown in Fig. 16. Read the value on the tension gauge as soon as the pinch wheel separates from the tape and tape travel stops. Ideal pinch wheel pressure is 1.8 kg.

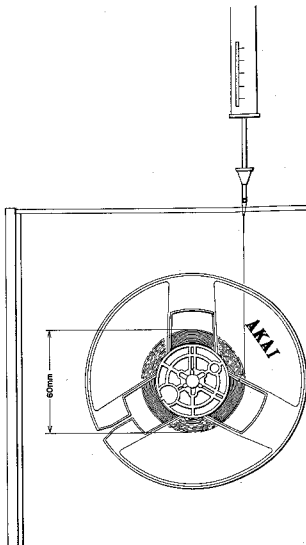

Fig. 17

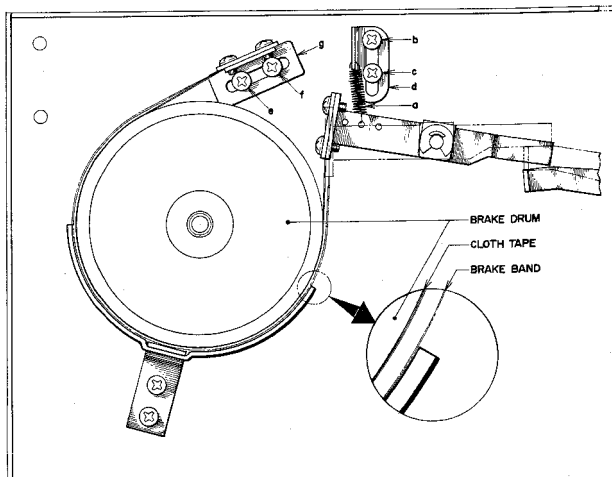

Fig. 18

3. BRAKE TENSION ADJUSTMENT

- 1) As shown in Fig. 17, use a 60 mm diameter tape wound on a 5" reel and measure the brake tension with a tension gauge. Ideal brake tension is from 300 to 370 grams.
- 2) Brake tension adjustment can be made as follows: (Refer to Fig. 18)
 - a) Change position of suspended spring (a).
 - b) Loosen screws (b) and (c) and adjust the vertical position of spring suspension metal (d).
 - c) Loosen screws (e) and (f) and adjust the horizontal position of brake band suspension metal (g).
 - d) Only the left side is shown in Fig. 18, but the right side must be adjusted in the same way.

NOTE: In making brake tension adjustment, at all modes except stop mode, confirm that the brake band completely separates from the cloth tape on the brake drum. (Refer to Fig. 18)

4. SUPPLY VOLTAGE AND TENSION AT VARIOUS OPERATING MODES

Torque Motor	Left Side	Right Side
Mode		
Normal P.B.	30 V (34 V) 60 g	60 V (68 V) 200 g
Reverse P.B.	60 V (68 V) 200 g	30 V (34 V) 60 g
F.FWD	5.8 V (6 V) 15 g	94.2 V (103 V) 460 to 480 g
RWD	94.2 V (103 V) 460 to 480 g	5.8 V (6 V) 15 g
Tension Relay at Operating Time	45 V (51 V) 100 g	45 V (51 V) 100 g

The voltage shown in parentheses are at 60 Hz.

Chart 2

VI. HEAD ADJUSTMENTS

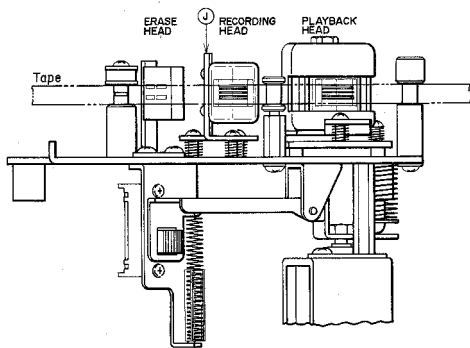
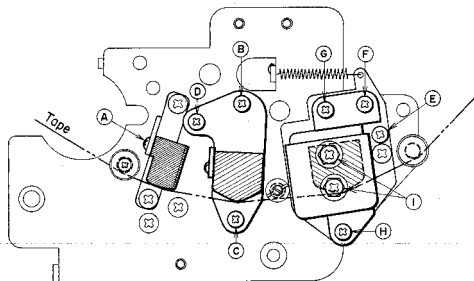

Fig. 19

1. HEAD HEIGHT ADJUSTMENT

1) Erase Head

At Playback mode, loosen screws (A) shown in Fig. 19 and adjust head height so that the upper edge of the tape is about 0.1 mm lower than the upper edge of the left channel erase head core.

2) Recording Head

At Playback mode adjust recording head height by turning screws (B) (C) and (D) shown in Fig. 19 to left and right until the upper edge of the tape is the same height as the upper edge of the left channel recording head core.

3) Playback Head

a) At Forward Playback mode, adjust playback head height by turning screws (F) (G) and (H) shown in Fig. 19 to left and right until the upper edge of the tape is the same height as the upper edge of the left channel playback head core.

b) At Reverse Playback mode, adjust playback head height by turning screw (E) shown in Fig. 19 to left and right until the lower edge of the tape is the same height as the lower edge of the right channel playback head core.

2. HEAD AZIMUTH ALIGNMENT ADJUSTMENT

1) Playback Head

- a) Connect a high sensitivity V.T.V.M. to the line output terminals.
- b) Set both the Tape Speed Switch and Equalizer Switch to 7-1/2 ips (19 cm/sec), depress STEREO Track Selector, and set the Monitor Switch to TAPE position.
- c) In case of model GX-225D, set Noise Reduction Switch to OFF position.
- d) Playback an 8,000 Hz 3-3/4 ips recorded Ampex Alignment test tape.
- e) At Forward Playback mode, turn Azimuth Alignment Screw (F) shown in Fig. 19 to obtain maximum line output level on both channels.
- f) After the adjustment in Item e) above has been completed, loosen screws (I) shown in Fig. 19 and move the head gap side of the playback head to left and right. When tension is applied to the supply reel side and the line output level of both channels do not fluctuate, (maximum allowable fluctuation within +0.5/-0 dB) fix screws (I) to maintain this condition.
- g) At reverse playback mode, make the same adjustment as outlined above until the line output level of both channels do not fluctuate.

2) Recording Head

- a) Connect an audio frequency oscillator to the line input terminals, and connect a high sensitivity V.T.V.M. to the line output terminals and load a blank tape.
- b) Set both the Tape Speed Switch and Equalizer switch to 7-1/2 ips (19 cm/sec.), depress STEREO Track Selector, and set the monitor switch to TAPE position.
- c) Record a 16,000 Hz audio frequency at -10 dB recording level.
- d) At recording mode, turn Azimuth Alignment Adjustment Screw (D) shown in Fig. 19 to left and right until the line output level of both channels is maximum and does not fluctuate.
- e) After completing adjustment in Item d) above, adjust gap side of recording head by bending installation angle (J) shown in Fig. 19 to left and right until the line output level of both channels do not fluctuate (maximum allowable fluctuation within +0.5/-0 dB) when tension is applied to the supply reel side.

3. To obtain best results, repeat adjustments outlined in paragraphs 1 and 2 above 2 or 3 times.

New blank tape should be used when making these adjustments.

VII. AMPLIFIER ADJUSTMENTS

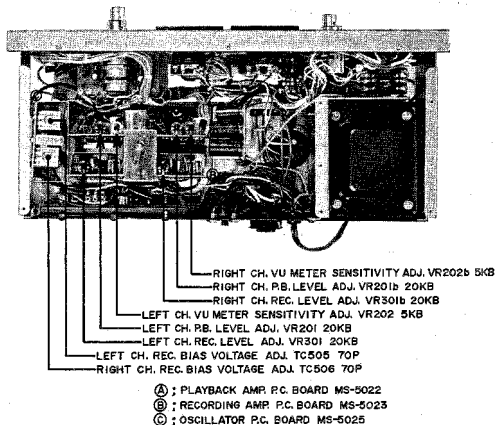

Fig. 20

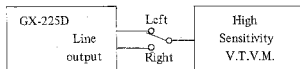

Fig. 21

1. PLAYBACK OUTPUT LEVEL ADJUSTMENT

- 1) Connect a high sensitivity V.T.V.M. to the line output terminals.
- 2) Set both the Tape Speed Switch and Equalizer Switch to 7-1/2 ips (19 cm/sec.), depress STEREO Track Selector and set the Monitor Switch to TAPE position.
- 3) In case of model GX-225D, set Noise Reduction Switch to OFF position.
- 4) Playback a 250 Hz "0" VU pre-recorded test tape.
- 5) Adjust P.B. Amp. P.C. Board playback level adjustment semi-fixed resistors VR201 20 kΩ (Left Channel) and VR201b 20 kΩ (Right Channel) shown in Fig. 20 to obtain a High Sensitivity V.T.V.M. indication of 4 dB (1.228 V)

2. VU METER SENSITIVITY ADJUSTMENT

After the playback output level adjustment has been completed, adjust P.B. Amp. P.C. Board VU meter sensitivity adjustment semi-fixed resistors VR202 5 kΩ (Left Channel) and VR202b 5 kΩ (Right Channel) shown in Fig. 20 to obtain a VU meter indication of "0" VU on both channels.

3. HIGH FREQUENCY DEVIATION CHECK

- 1) Between Channels
When an 8,000 Hz 3-3/4 ips Ampex Alignment test tape is played back, check to confirm that the difference in high range output level between the left and right channel is within 2 dB.
- 2) Between FWD and REV Playback
Playback and Alignment test tape and check to confirm that the difference in high range level output between FWD and Reverse playback mode is within 3 dB.
- 3) If Items 1) and 2) above are not within specifications, repeat Head Azimuth Alignment adjustment.

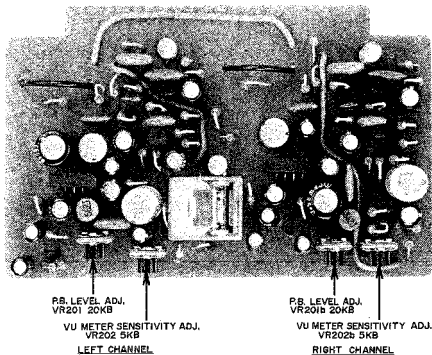
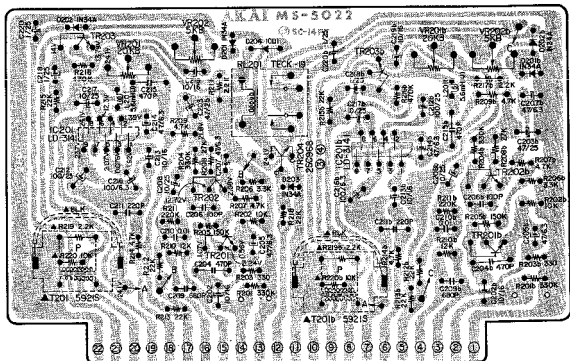

Fig. 22 P.B. AMP. P.C. BOARD (Face Side)



MODEL	T201	R21S	R22O	LEAD W/RE (BLK)
GX-221	X	○	X	○
GX-221D	○	X	X	X
GX-225D	X	○	○	X

TR201, 202 ... 25C871 (P)
 TR203 ... 25C945 (M) (C)

Fig. 23 P.B. AMP. P.C. BOARD MS-5022 (Reverse Side)

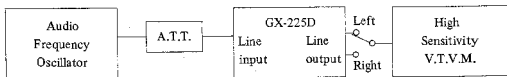
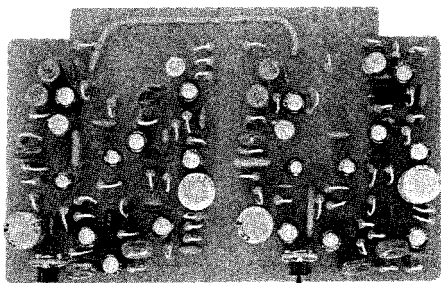

Fig. 24



LEFT CH. REC. LEVEL ADJ.
VR301 20K Ω

RIGHT CH. REC. LEVEL ADJ.
VR301b 20K Ω

Fig. 25 REC. AMP. P.C. BOARD (Face Side)

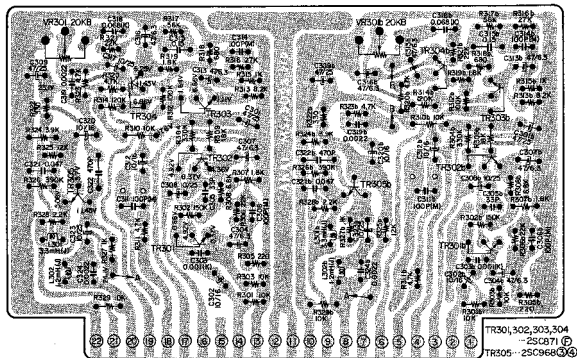

Fig. 26 REC. AMP. P.C. BOARD MS-5023 (Reverse Side)

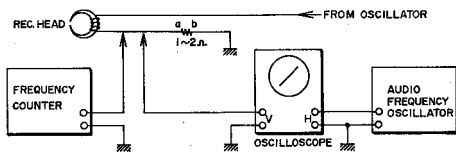

Fig. 27

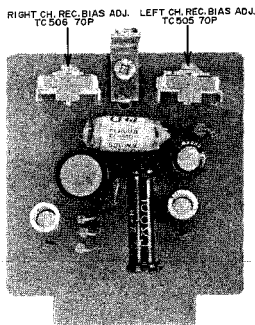

Fig. 28 OSC. P.C. BOARD (Face Side)

4. RECORDING LEVEL ADJUSTMENT

- 1) Connect an Audio Frequency Oscillator to the line input terminals through an attenuator, and connect a high sensitivity V.T.V.M. to the line output terminals.
- 2) Set both the Tape Speed Switch and the Equalizer Switch to 7-1/2 ips (19 cm/sec), depress the STEREO Track Selector, and set the Monitor Switch to TAPE position.
- 3) In case of model GX-225D, set Noise Reduction Switch to OFF position.
- 4) Set Recording Level Controls to maximum and load a blank tape (AKAI 100L Tape).
- 5) Set recorder to recording mode, and supply a 1,000 Hz signal from the Audio Frequency Oscillator. Adjust attenuator to obtain a V.T.V.M. indication of 4 dB.
- 6) Set Monitor Switch to SOURCE position, and adjust Rec. Amp. P.C. Board recording level adjustment semi-fixed resistors VR301 20 k Ω (Left Channel), and VR301b 20 k Ω (Right Channel) shown in Fig. 20 to obtain a V.T.V.M. indication of 4 dB on both channels.

5. RECORDING BIAS FREQUENCY MEASURING METHOD

Method 1

- 1) As shown in Fig. 27, install a 1 to 2 Ω resistor in series with the recording head and connect the vertical input of an oscilloscope to these terminals (a and b).
- 2) Supply a sine wave signal from an Audio Frequency Oscillator to the horizontal input of the oscilloscope.

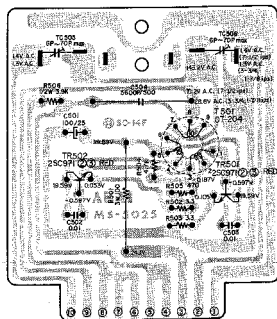

VIII. AUTOMATIC NOISE REDUCTION AMPLIFIER ADJUSTMENTS (Model GX-225D only)

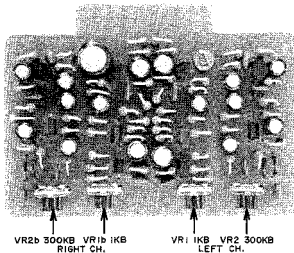
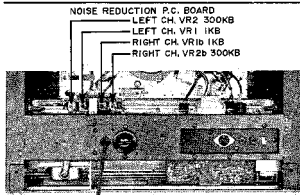

Fig. 31 AUTOMATIC NOISE REDUCTION AMP. P.C. BOARD (Face Side)

1. A.N.R. AMP. ADJUSTMENT

- 1) Connect the various measuring instruments as shown in Fig. 24.
- 2) Set recording level adjustment volumes VR1a 50 kA (Left Channel) and VR1b 50 kA (Right Channel) to maximum.
- 3) Set the Noise Reduction Switch and the S.O.S. Switch to OFF position, and set Monitor Switch to SOURCE.
- 4) Set tape deck to recording mode, and supply a 100 Hz signal to the line input terminals from the Audio Frequency Oscillator. Adjust attenuator to obtain a high sensitivity V.T.V.M. indication of 4 dB (VU meter indication "0" VU).
- 5) Adjust Noise Reduction P.C. Board semi-fixed resistors VR2 300 kB (Left Channel) and VR2b 30 kB (Right Channel) shown in Fig. 30 so that when the Noise Reduction Switch is set to ON position, a line output level of 4 dB is maintained.
- 6) Return Noise Reduction Switch to OFF position and set the oscillation frequency of the Audio Frequency Oscillator to 10 kHz. Then adjust the attenuator to obtain the same results as outlined in Item 4) above.
- 7) Set Noise Reduction Switch to ON position, and at this time, adjust Noise Reduction P.C. Board semi-fixed resistors VR1 1 kB (Left Channel) and VR1b 1 kB (Right Channel) shown in Fig. 30 to obtain a line output level decrease of 2.5 dB.
- 8) After the adjustments in Items 1) through 7) have been completed, decrease the 10 kHz signal by 30 dB and supply this signal to the line input. Confirm that the line output level is 6 ± 0.5 dB lower when the Noise Reduction Switch is at ON position than when at OFF position.

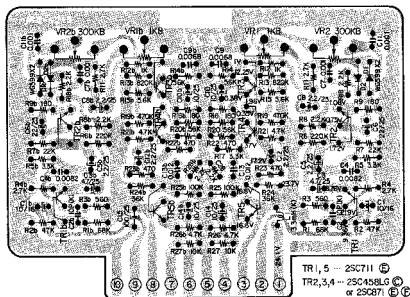

Fig. 32 AUTOMATIC NOISE REDUCTION AMP. P.C. BOARD MS-5215 (Reverse Side)

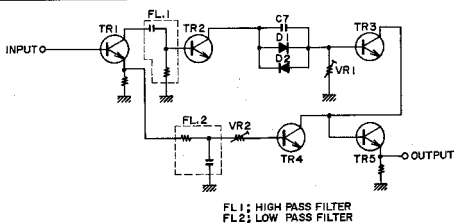

Fig. 33 A.N.R. AMP. BLOCK DIAGRAM

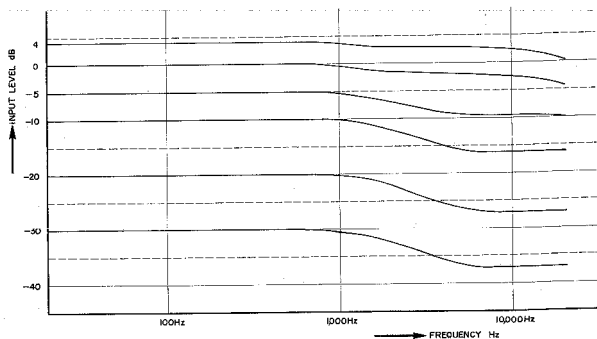
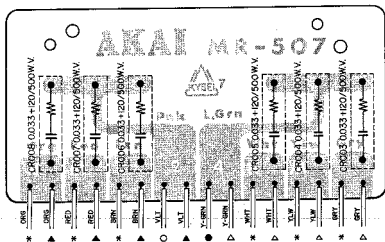

Fig. 34 AUTOMATIC NOISE REDUCTION AMP. CHARACTERISTICS

2. A.N.R. OPERATION AND CHARACTERISTICS (Refer to Fig. 33 & 34)

- 1) The TR1 output signal passes the high pass filter and the low pass filter and is supplied to TR2 and TR4 respectively.
- 2) The TR2 output passes diodes D1 and D2 as well as condenser C7 and is supplied to TR3. In case the input signal is high, D1 and D2 decreases the impedance and the signal supplied to TR3 is unchanged. Also the signal which passed FL2 is amplified at TR4 and the TR3 and TR4 signals merge at the input side of TR5 and become a composite signal.
- 3) In case the level of the signal which passed High Pass Filter FL1 is small, diodes D1 and D2 increases the impedance relative to this signal level and the signal supplied to TR3 is even smaller. The signal which passes Low Pass Filter FL2, because there are no variable impedance components such as D1 and D2, is supplied to TR4 unchanged. Consequently, both signals merge, becoming a composite signal and the output becomes a high frequency reduced signal in relation to a low level input.
- 4) The characteristics of diodes D1 and D2 increases the impedance of low level signals (the lower the level, the more the impedance is increased) so that the signal supplied to TR3 is close to zero. Consequently, the purpose of condenser C7 is to prevent decrease below a certain level.

3. SPARK QUENCHER P.C. BOARD MR-507



- NOTE
- * : TO CAPSTAN MOTOR TYPE HC-16X
 - ▲ : FROM TAPE SPEED SWITCH SW-005
 - △ : FROM TAPE SPEED SWITCH SW-004
 - : FROM TENSION RELAY P.C. BOARD MR-555
 - : FROM SYSTEM CONTROL P.C. BOARD MR-504

4. TRACK SELECTOR P.C. BOARD MS-5055

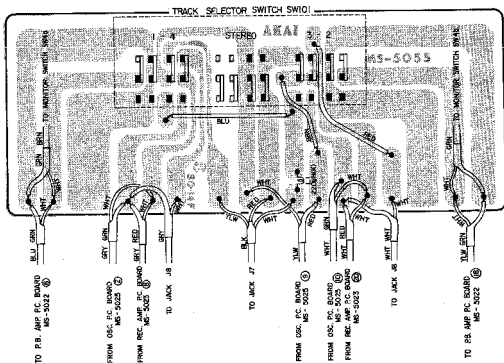

5. EQUALIZER SWITCH P.C. BOARD MS-5027

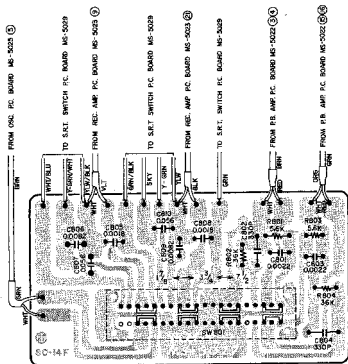

6. S.R.T. SWITCH P.C. BOARD MS-5029

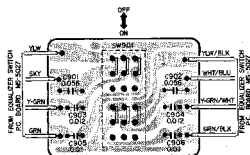

7. POWER SUPPLY P.C. BOARD MS-5030

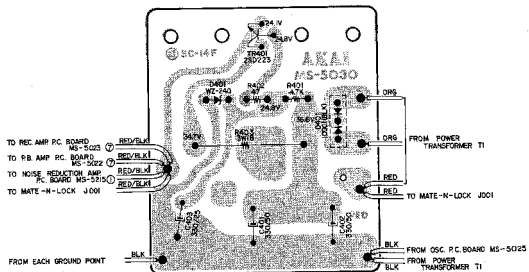

8. TONE CONTROL P.C. BOARD MS-5028

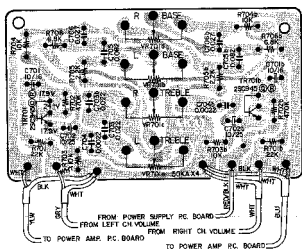

9. HEAD PHONE TRANS.

P.C. BOARD MS-5216

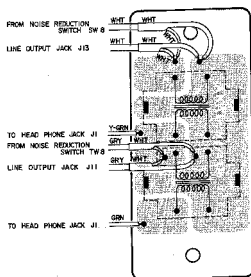

10. POWER AMP. P.C. BOARD MS-5024

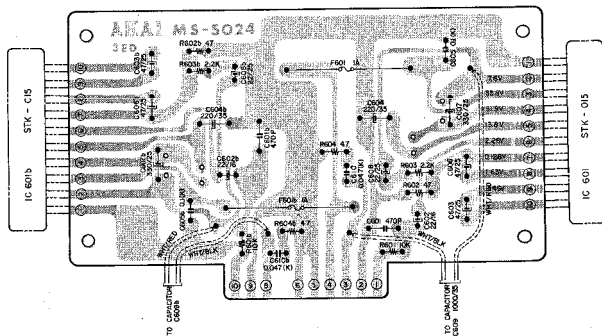

SECTION 2

PARTS LIST

TABLE OF CONTENTS

FIG. 1	MS HEAD BLOCK	33
FIG. 2	REEL MOTOR & REEL TABLE BLOCK	33
FIG. 3	MAIN MOTOR BLOCK	35
FIG. 4	FLYWHEEL BLOCK	37
FIG. 5	SWITCH BLOCK	39
FIG. 6	MECHANISM ASSEMBLY BLOCK	41
FIG. 7	TENSION RELAY P.C. BOARD (MR-558) BLOCK	42
FIG. 8	SYS. CON. P.C. BOARD (MR-504) BLOCK	43
FIG. 9	REC. AMP. P.C. BOARD (MS-5023) BLOCK	44
FIG. 10	P.B. AMP. P.C. BOARD (MS-5022) BLOCK	45
FIG. 11	NOISE REDUCTION P.C. BOARD (MS-5215) BLOCK	46
FIG. 12	TONE CONTROL P.C. BOARD (MS-5028) BLOCK	47
FIG. 13	MAIN AMP. BLOCK	48
FIG. 14	OSC. P.C. BOARD (MS-5025) BLOCK	49
FIG. 15	EQUALIZER P.C. BOARD (MS-5027) BLOCK	49
FIG. 16	SRT P.C. BOARD (MS-5029) BLOCK	50
FIG. 17	TRACK SELECTOR P.C. BOARD (MS-5055) BLOCK	50
FIG. 18	POWER SUPPLY P.C. BOARD (MS-5030) BLOCK	51
FIG. 19	AMPLIFIER ASSEMBLY BLOCK	53
FIG. 20	FINAL ASSEMBLY BLOCK	55
INDEX		56

HOW TO USE THIS PARTS LIST

1. This parts list is compiled by various individual blocks based on assembly process.
2. When ordering parts, please describe parts number, serial number, and model number in detail.
3. How to read List

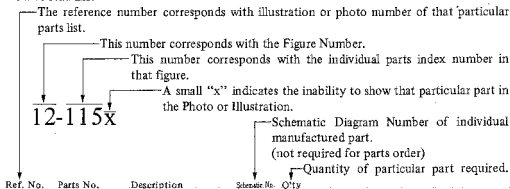

Ref. No.	Parts No.	Description	Schematic No.	Q'ty
----------	-----------	-------------	---------------	------

FLYWHEEL BLOCK #13

12-115x	806425	Flywheel Block Assy. Comp.	RDGP-12	1
12-116	244506	Flywheel Only	RD-233	1
12-117x	244754	Felt, Flywheel	RD-275	1
12-118	251324	Main Metal Case	RD-226	1
12-119	253080	Main Metal	RD-237	1

4. The symbol numbers shown on the P.C. Board list can be matched with the Composite Views of Components of the Schematic Diagram or Service Manual.
5. The indications of Resistors and Capacitors in the photos of P.C. Board are being eliminated.
6. The shape of the parts and parts name, etc. can be confirmed by comparing them with the parts shown on the Electrical Parts Table of P.C. Board.
7. Both the kind of part and installation position can be determined by the Parts Number. To determine where a parts number is listed, utilize Parts Index at end of Parts List.
It is necessary first of all to find the Parts Number. This can be accomplished by using the Reference Number listed at right of parts number in the Parts Index. (meaning of ref. no. outlined in Item 3 above).
8. Utilize separate "Price List for Parts" to determine unit price. The most simple method of finding parts Price is to utilize the reference number.

ELECTRICAL PARTS TABLE

<p>ELECTRICAL PARTS LIST TABLE Because the indications of resistors and capacitors in the P.C. Board plates are being minimized, please consider part name and shape by comparing them with the parts shown in this table.</p>	<p style="text-align: center;">1</p>  <p style="text-align: center;">Solid Resistor</p>	<p style="text-align: center;">2</p>  <p style="text-align: center;">Carbon Resistor</p>	<p style="text-align: center;">3</p>  <p style="text-align: center;">Metal Oxide Film Resistor</p>
<p style="text-align: center;">4</p>  <p style="text-align: center;">General Resistor</p>	<p style="text-align: center;">5</p>  <p style="text-align: center;">Wire-Wound Resistor</p>	<p style="text-align: center;">6</p>  <p style="text-align: center;">Thermistor</p>	<p style="text-align: center;">7</p>  <p style="text-align: center;">Electrolytic Resistor</p>
<p style="text-align: center;">1</p>  <p style="text-align: center;">MF Capacitor (Tubular Type)</p>	<p style="text-align: center;">2</p>  <p style="text-align: center;">Plastic Capacitor</p>	<p style="text-align: center;">3</p>  <p style="text-align: center;">Mica Capacitor</p>	<p style="text-align: center;">4</p>  <p style="text-align: center;">VFM (HIG) Capacitor</p>
<p style="text-align: center;">8</p>  <p style="text-align: center;">Hybrid Capacitor</p>	<p style="text-align: center;">6</p>  <p style="text-align: center;">Tantalum Capacitor</p>	<p style="text-align: center;">7</p>  <p style="text-align: center;">Oil Capacitor (Tubular Type)</p>	<p style="text-align: center;">5</p>  <p style="text-align: center;">Vertical Type Styrol Capacitor</p>
<p style="text-align: center;">9</p>  <p style="text-align: center;">Electrolytic Capacitor (Tubular Type)</p>	<p style="text-align: center;">10</p>  <p style="text-align: center;">Electrolytic Capacitor</p>	<p style="text-align: center;">11</p>  <p style="text-align: center;">Ceramic Capacitor</p>	<p style="text-align: center;">12</p>  <p style="text-align: center;">Metalized Mylar (Paper) Capacitor</p>
<p style="text-align: center;">13</p>  <p style="text-align: center;">Trimmer Condenser</p>	<p style="text-align: center;">VR</p>  <p style="text-align: center;">Variable Reactor</p>		
<p style="text-align: center;">L</p>  <p style="text-align: center;">Ferrite Inductor</p>	<p style="text-align: center;">TR</p>  <p style="text-align: center;">Transistor</p>		
<p style="text-align: center;">CR</p>  <p style="text-align: center;">Spark Oscillator</p>	<p style="text-align: center;">D</p>  <p style="text-align: center;">Diode (Silicon, Zener, Germanium)</p>		

FIG. 1 ILLUSTRATION OF MS HEAD BLOCK

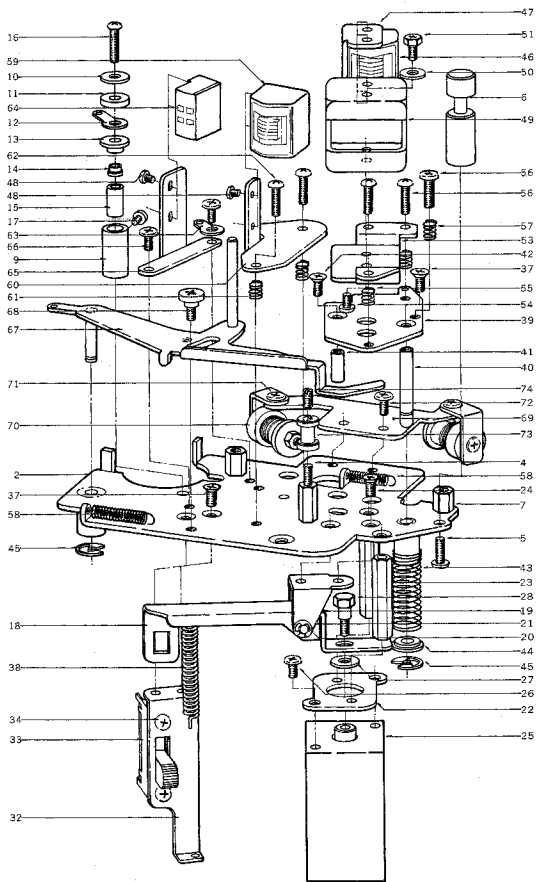

MS HEAD BLOCK

Ref. No.	Parts No.	Description	Schematic No.	Q'ty
1-1x	BH426047	MS Head Block Comp.		1
1-2	HZ425417	Head Base Plate, w/metal	MS-0061	1
1-3x	MZ303298	T Arm Cushion (Rubber)	RD-281	2
1-4	HZ425542	Tape Guide Prop B	MS-0003	1
1-5	ZW417025	Screw, binding head 3x8, w/washer		3
1-6	HZ425597	Tape Guide Prop C	MS-0011	1
1-7	HZ425586	Head Cover Post	MS-0004	1
1-8x	ZW413188	Nut, M4		2
1-9	HZ425430	Tape Guide Prop A	MS-0012	1
1-10	ZW396786	Tape Guide Washer	ED-0035	1
1-11	HZ396505	Insulator Collar	ED-0087	1
1-12	ZW273778	Earth Lug, M3		1
1-13	HZ396595	Sensing Guide B	KD-0016	1
1-14	HZ317632	Insulator Collar A	MR-34	1
1-15	HZ396797	Sensing Guide	KD-0035	1
1-16	ZW202252	Screw, round head 2.3x12		1
1-17	ZW432674	Screw, pan head 3x3		1
1-18	HL317676	Plunger Lever	MR-16	1
1-19	HZ317687	Lever Support	MR-15	1
1-20	ZW257477	Connecting Pin	RD-211	1
1-21	ZW270088	'E' Ring 1.9M	6-1-9	1
1-22	HZ317698	Plunger Base	ED-21	1
1-23	HZ317700	Plunger Retaining Prop	MR-6	2
1-24	ZW432685	Screw, countersunk head 3x6		2
1-25	EP318115	Plunger Solenoid RGA10143	44-1-25	1
1-26	ZW413223	Screw, binding head 3x5, w/washer		2
1-27	ZW450753	Washer (Nylon) D4.1x9x11		1
1-28	ZW317711	Plunger Bolt	MR-17	1
1-29x	EJ299788	6P Plug	42-1-21	1
1-30x	EJ425632	4P Plug, Consent S-15908	42-1-21	1
1-31x	MZ314403	Nylon Clip HP-2N		3
1-32	HZ317733	Slide Switch Base	MR-18	1
1-33	ES317744	Slide Switch SL-242B4V	22-3-28	1
1-34	ZW432696	Screw, round head 2.5x5		2
1-35x	ZW317801	Toothed Lock Washer, M2.6		2
1-36x	EJ308981	Mold 4P Plug	42-1-22	1
1-37	ZW200417	Screw, countersunk head 3x6		3
1-38	ZG317766	Plunger Lever Spring	MR-19	1
1-39	HZ425507	P.B. Head Hold-down Table	MS-0005	1
1-40	MS317891	PH Shaft	MR-11	1
1-41	HZ298012	4 TR Hold-down Base Guide	3A-99	1
1-42	ZW432663	Screw, countersunk head 2.3x6		1
1-43	ZG317902	PH Spring	MR-13	1
1-44	ZW317913	Spring Holder	MR-12	1
1-45	ZW290283	'U' Ring 2.85M	6-1-1	2
1-46	HP384524	P.B. HEAD P4-200		1
1-47	HZ428387	Head Angle	MS-0007	1
1-48	ZW201475	Screw, pan head 2x3		6
1-49	HZ382667	Triple-shield	RD-A3	1
1-50	ZW426622	Washer (SPC) D3.4x7.8x0.51		2
1-51x	ZW403312	Hexagon Bolt 3x4		4
1-52x	EA463206	P.C. Board, Terminal A	RD-A36	4
1-53	HZ425520	P.B. Head Adjust Table	MS-0006	1
1-54	ZW202691	Screw, round head 3x4		2
1-55	ZG425531	P.B. Head Spring	MS-0008	3
1-56	ZW345914	Screw, round head 3x10		4
1-57	ZG303300	Angle Adjust Spring B	RD-35	1
1-58	ZG315011	Brake Lever Spring	MR-112	2
1-59	HR384513	REC. HEAD R4-200		1
1-60	HZ425564	RH Angle	MS-0009	1
1-61	ZG206144	Angle Adjust Spring	RD-16	3
1-62	ZW336868	Screw, round head 3x12		3
1-63	ZW273881	Earth Lug, M4		1
1-64	HE412187	ERASE HEAD E4-250		1
1-65	HZ425575	Erase Head Base	MS-0010	1
1-66	ZW332728	Screw, binding head 3x5		2
1-67	HL425608	Shifter Lever B, w/shaft	MS-0012	1
1-68	ZW340674	XR Idler Lever Screw	XR-370	1
1-69	HZ425643	Cancel Coil Table	MS-0016	1
1-70	EO337208	Form Backing Coil 1ST	23-1-37	2
1-71	ZW413223	Screw, binding head 3x5, w/washer		2
1-72	ZW323728	Screw binding head 3x5		2

Ref. No.	Parts No.	Description	Schematic No.	Q'ty
1-73	HZ331884	Tape Guide B	RD-5	1
1-74	ZW384840	Set Screw 3x5 (cup)		1

REEL MOTOR & REEL TABLE BLOCK

Ref. No.	Parts No.	Description	Schematic No.	Q'ty
2-1	BM314741	Reel Motor Block Comp.	MS-3/C, MR-KD	1
2-2x	BR426036	Reel Table Block Comp.		1
2-3x	BR426025	Reel Table Block Comp. (Take-up) MS (Supply) MS		1
2-4	MT425970	MS Reel Table Disc	MS-2001	1
2-5	MT255420	Reel Retainer	3R-102	1
2-6	MS342000	Reel Shaft	3R-108	1
2-7	ZG255633	Reel Spring	3R-109	1
2-8	MT297663	3R.'O' Ring 2.9x1.65M	3R-159	1
2-9	ZW270088	'E' Ring 1.9M	6-1-9	1
2-10	MT397225	Reel Table Rubber	KD-2017	1
2-11	MT495606	Brake Drum (R) A (Take-up)	MR-216	1
2-12x	MT495617	Brake Drum (L) A (Supply)	MR-216	1
2-13x	ZW273778	Earth Lug, M3		2
2-14x	ZW425981	Screw, binding head 3x3		2
2-15	MT436660	Brake Cloth Comp.	MR-160	1
2-16	ZG317496	Felt Tension Spring	MR-209	1
2-17	ZW424056	Screw, pan head 4x1.0		2
2-18	ZW425992	Screw, countersunk head 3x8		3
2-19	MR426958	Counter Pulley (Take-up)	MS-4912	1
2-20	ZW516655	Screw, countersunk head 2.3x8		2
2-21	MZ317373	Brake Lever Prop	MR-102	2
2-22x	ZW413188	Nut, M4		2
2-23	ML314976	Brake Lever A (Take-up)	MR-216	1
2-24x	ML396810	Brake Lever B (Supply)	KD-1603	1
2-25	MB314987	Brake Band	MR-213	2
2-26	MZ314998	Brake Band Retaining Plate	MR-213	4
2-27x	ZW417137	Screw, binding head 3x4		8
2-28	MZ315000	Brake Band Support	MR-214	2
2-29	ZG315011	Brake Lever Spring	MR-216	2
2-30	ZW290283	'U' Ring 2.85M	6-1-1	2
2-31x	ZW323728	Screw, binding head 3x5		4
2-32	MZ317406	Brake Band Guide, w/base	MR-120	2
2-33	MB303535	Counter Belt D91x1.6	3A-411	1

When ordering parts, please describe Parts Number, Serial Number, and Model Number in detail.

FIG. 2 ILLUSTRATION OF REEL MOTOR & REEL TABLE BLOCK

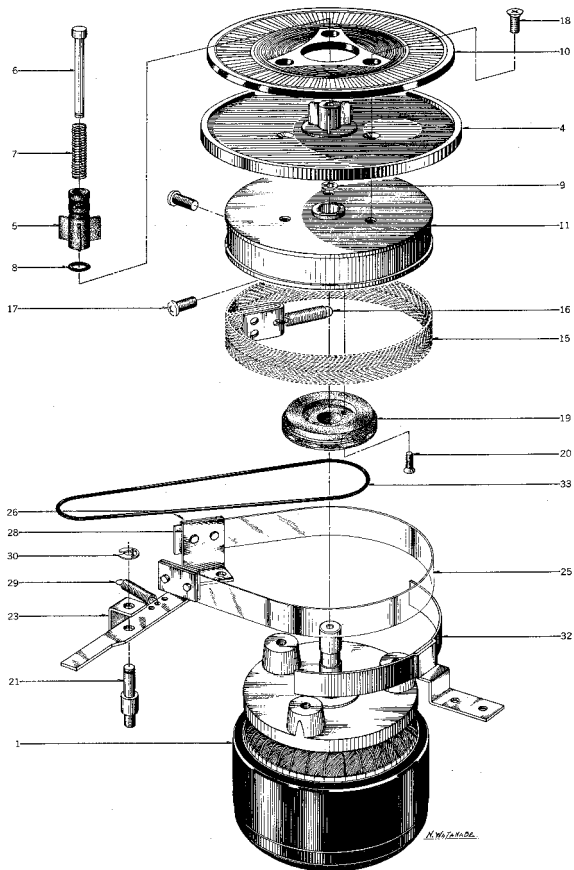
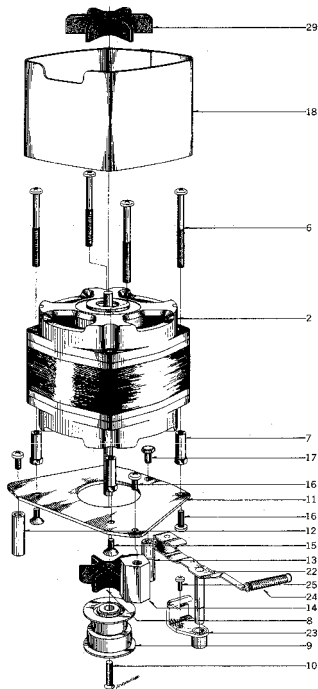

FIG. 3 ILLUSTRATION OF MAIN MOTOR BLOCK



MAIN MOTOR BLOCK

Ref. No.	Parts No.	Description	Schematic No.	Q'ty
			MS-2,3,MR	1
3-1x	BM437040	Main Motor Block Comp.		1
3-2	MZ448222	24 Motor Cover, w/metal	24X-781	2
3-3x	ZW228025	Thrust Adjust Washer A 0.11	24X-714	8
3-4x	ZW228036	Thrust Adjust Washer B 0.25t	24X-715	8
3-5x	ZW228194	Thrust Washer (Nylon) 0.5t	24X-717	2
3-6	ZW201745	Screw, pan head 4x50, w/washer		4
3-7	MZ254327	Motor Mt. Prop	16X-767	4
3-8	MZ316247	MR Motor Fan	MR-719	1
3-9	MR437602	MC Motor Pulley	MC-7002	1
3-10	ZW203016	Screw, oval countersunk head 3x15		4
3-11	MZ316293	MR Motor Mt. Plate	MR-717	1
3-12	MZ254160	Motor Prop A	24X-730	1
3-13	MZ254182	Motor Prop B	24X-731	1
3-14	MZ316304	MR Motor Prop	MR-766	1
3-15	ZW427026	Screw, countersunk head 4x10		2
3-16	ZW424056	Screw, pan head 4x10		4
3-17	ZW272395	M-7 Motor Prop Retaining Screw	14X-732	1
3-18	MZ316326	Motor Out-side Shield (large) A	16X-714	1
3-19x	MZ337724	Motor Out-side Shield (large) B	16X-716	1
3-20x	MZ292364	XR Motor Shield Plate B	XR-705	1
3-21x	BL437038	Belt Change Lever Block Comp.	D	1
3-22	ML437591	Belt Change Lever D (small), w/roller	MC-1011	1
3-23	MZ248354	Belt Guide Stop, w/metal	4TR-221	1
3-24	ZG217337	Belt Return Spring	4TR-224	1
3-25	ZW417150	Screw, pan head 4x6		1
3-26x	ZG217394	Belt Change Spring B	MR-135	1
3-27x	ZW260054	Washer (SUP) D6.1x1.0x0.25t		1
3-28x	ZW290283	'U' Ring 2.85M	6-1-1	1
3-29	MZ254441	Motor Fan (large)	RD-640	1
3-30x	MZ404820	Dust Cover Plate (Nylon)D24x1t	RD-A640	1

When ordering parts, please describe Parts Number, Serial Number, and Model Number in detail.

FIG. 4A ILLUSTRATION OF FLYWHEEL BLOCK

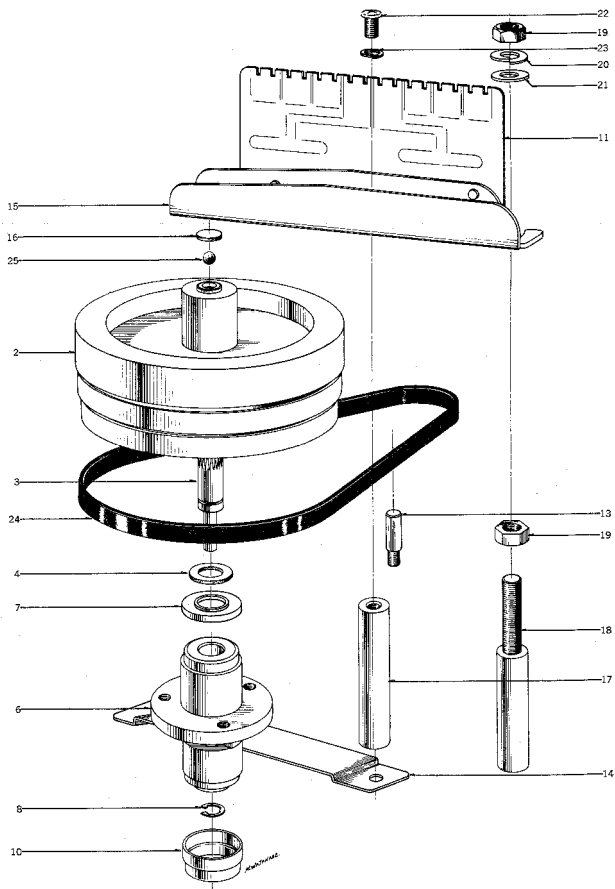
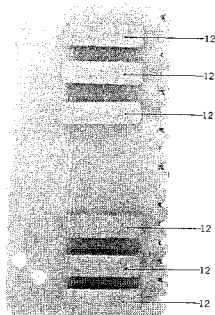

FIG. 4B PHOTO OF FLYWHEEL BLOCK



FLYWHEEL BLOCK

Ref. No.	Parts No.	Description	Schematic No.	Qty
4-1x	BF476550	Flywheel Block Comp.	MS 2.1.MR	1
4-2	MZ296245	Flywheel 24	MR-201	1
4-3	MS476572	D6 Main Shaft	MR-1905	1
4-4	ZW447208	Flywheel Thrust B		
		D7.9x13x0.5t	10025	1
4-5x	ZW373577	Set Screw, hexagon socket		
		5x6 (Flat)		2
4-6	MZ296256	Main Case A 24, w/metal	MR 206	1
4-7	MZ446635	Thrust Cap. Main Metal B2	LP-2096	1
4-8	ZW244710	Flywheel Fixing Pin	990-250	1
4-9x	MZ244113	Felt D12.5x16x2t		1
4-10	MZ253113	Main Metal Cap B	MR-208	1
4-11	BA334541	Spark Quencher P.C. Board		
		Comp. (MR-507)		1
4-12	ER450797	Spark Quencher U/L		
		0.035μ+120 400WV	41-1-34	6
4-13	MZ248313	Belt Guide Pin	478-169	1
4-14	MB439525	Flywheel Belt Holding Plate B	MS-1014	1
4-15	MZ314897	Flywheel Supporting Plate MR	MR-121	1
4-16	ZW392681	Washer, without hole		
		(Nylon) D8x1t		1
4-17	MZ273036	M9 Flywheel Prop A	MR 319	1
4-18	MZ273047	M9 Flywheel Prop B	MR-311	1
4-19	ZW413280	Inch Nut, 1/4" (P20)		2
4-20	ZW393232	Spring Washer, 1/4"		1
4-21	ZW413998	Washer (SUF) D6.8x12.7x1t		1
4-22	ZW413261	Screw, pan head 4x8		1
4-23	ZW273914	Spring Washer, M4		1
4-24	MB437703	MC Flywheel Belt	MC-1013	1
4-25	MV269965	Steel Ball D4		1
4-26x	ZW323728	Screw, binding head 3x5		2

When ordering parts, please describe Parts Number, Serial Number, and Model Number in detail.

FIG. 5 ILLUSTRATION OF SWITCH BLOCK

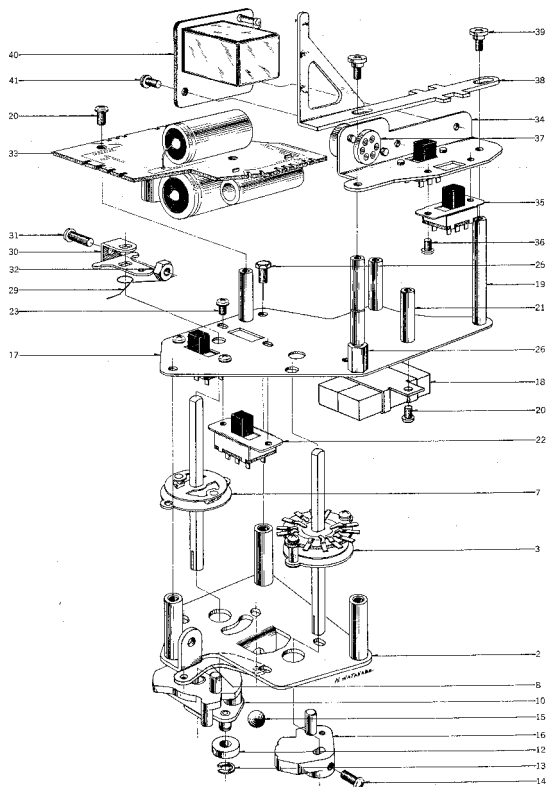

SWITCH BLOCK

Ref. No.	Parts No.	Description	Schematic No.	Q'ty
5-1x	BS433787	Switch Block Comp.	MS	1
5-2	HZ402390	Switch Table A-2 (MR), w/prop	MR-201	1
5-3	ES425924	Play Shaft (Y Type) Y-263-2	25-7-24	1
5-4x	ZW460157	Washer (SPC) D3.1x8x0.8t		2
5-5x	ZW348107	ISO Nut, M3		2
5-6x	ER345756	Carbon/R. RD1/4 68k (J)		
		(Insu. type)	25 9-5	1
5-7	ES316934	Y type Rwd Shaft	25-6-5	1
5-8	MZ316945	Nut Plate	MR-245	1
5-9x	ZW413728	Screw, binding head 3x6, w/washer		2
5-10	MZ316956	Cam A-3, w/plate	MR-242	1
5-11x	ZW259942	Washer (Fiber) D5.1x10.3x0.5t		1
5-12	MR269750	Cam Koller U12	900-213	1
5-13	ZW290283	'U' Ring 2.85M	6-1-1	1
5-14	ZW413201	Screw, pan head 4x8		2
5-15	MV270066	Steel Ball D8		1
5-16	MZ217271	Cam B, without tap	900-206	1
5-17	MZ316967	Control Chassis	MR-202	1
5-18	ER477663	Cement/R. H (15+15) H1A (22.5+22.5) K220J	35 16 33	1
5-19	MZ316978	Cycle Switch Prop	MR-207	1
5-20	ZW413223	Screw, binding head 3x5, w/washer		7
5-21	MZ364691	Sys. Con. P.C. Board Prop	MR-284	3
5-22	ES375478	Slide Switch ESD-279DU	25-3-21	2
5-23	ZW371856	ISO Screw, binding head 3x5		3
5-24x	ER376413	Spark Quencher U/L 0.033μ+120 500WV	41 1-37	1
5-25	MZ425935	Hexagon Bolt 4x8, w/washer		2
5-26	MZ317046	Rec. Lever Prop	MR-206	1
5-27x	MZ373318	Nylon Clip HP-3N		1
5-28x	ZW321298	ISO Screw, binding head 3x8		1
5-29	ZG225516	Switch Spring	MR-255	1
5-30	MZ317024	Switch Cam	MR-204	1
5-31	ZW424056	Screw, pan head 4x10		1
5-32	ZW413188	Nut, M4		1
5-33	BA324088	Sys. Con. P.C. Board Comp. (MR-504)		1
5-34	MZ425946	Frequency Switch Table	MS-1002	1
5-35	ES317531	Slide Switch ESD-271DU	25-3-24	2
5-36	ZW384131	Screw, round head 3x5		4
5-37	EJ365793	6P Socket	31-1-63	1
5-38	ML317542	Cycle Change Lever MR	MR-209	1
5-39	ZW207314	Amp. Lever Set Screw	2A-737	2
5-40	BA317081	Tension Relay P.C. Board Comp. (MR-538)		1
5-41	ZW413223	Screw, binding head 3x5, w/washer		2
5-42x	EJ293062	12P Mate-N-Lock Cap Housing 1-480278-0	52-1-1	1
5-43x	EJ373623	Pin Contact 61 116-1	52-1-1	12
5-44x	EJ317125	5P TV-Consent-Plug	42-1-6	1

When ordering parts, please describe Parts Number, Serial Number, and Model Number in detail.

Ref. No.	Parts No.	Description	Schematic No.	Q'ty
6-84x	ZW330434	Adjust Washer(U) D4x1.3x0.5t		1
6-85x	ZW330445	Adjust Washer(U) D4x1.3x0.5t		1
6-86	ML314763	MR Lever B, w/lever D	MR-122	1
6-87	MR314785	Cam Roller D9	MR-207	1
6-88	ZW290263	'U' Ring 2.85M	6-1-1	6
6-89	ZG314818	D Lever Spring	MR-114	1
6-90	ML334506	MR Lever A, w/metal	MR-126	1
6-91	ML314842	MR Lever C	MR-198	1
6-92x	ZW619826	Washer (Fiber) D6.2x10x1t		2
6-93	ML314864	IB Lever	MR-111	1
6-94	MZ260662	AS Lever Prop Base, w/prop	4TR-136	1
6-95x	ZW202116	Screw, binding head 3x5, w/lug		1
6-96	MZ218125	Gear Stopper	4TR-129	1
6-97	ZG226697	Stopper Spring	4TR-121	1
6-98	ML228868	Auto Mech. Control Lever	4TR-125	1
6-99	ZW260087	Washer (Fiber) D6.1x10x0.5t		1
6-100	ML314932	MR Pinch Roller Lever	MR-119	1
6-101	MS243404	Pinch Roller Shaft C	4TR-102	1
6-102x	ZW259975	Washer (SUP) D5.1x10.3x0.8t		3
6-103	ZW413188	Nut, M4		4
6-104	MR269763	Cam Roller D13	900-154	1
6-105	MS217192	Cam Roller Shaft A	900-170	1
6-106	ZG455692	Pinch Roller Spring (MS)	MS-1015	1
6-107	ML425790	Shifter Lever A	MS-1003	1
6-108x	ZW413223	Screw, binding head 3x5, w/washer		2
6-109	MZ425801	Shifter Stand, w/pin	MS-1004	1
6-110	ZW323728	Screw, binding head 3x5		1
6-111x	ZW314943	D8 Washer	MR-113	1
6-112	ML314976	Brake Lever A (Take-up)	MR-219	1
6-113	MB314987	Brake Band	MR-213	2
6-114x	MZ314998	Brake Band Retaining Plate	MR-212	4
6-115	ZW417137	Screw, binding head 3x4		8
6-116	MZ315000	Brake Band Support	MR-214	2
6-117	ZG315011	Brake Lever Spring	MR-116	2
6-118x	ML396810	Brake Lever B (Supply)	KD-1038	1
6-119	HZ315077	Reverse Guide Base w/prop	MR-229	1
6-120	HZ315090	Reverse Guide	RD-225	1
6-121x	ZW344463	Set Screw, hexagon socket 4x6 (cup)		1
6-122	ES488935	Tension Switch Comp. MS-2	MS-1011	1
6-123	MZ381701	Switch Angle Base	MR-262	1
6-124x	ZW273778	Earth Lug, M3		1
6-125x	ZW427048	Screw, round head 3x3		2
6-126	MZ210071	Auto. Switch Plate	MR-116	1
6-127	ES375478	Slide Switch ESD-279DU	ES-1-22	1
6-128	ZW440291	ISO Screw, countersunk head 3 x 6		2
6-129	ES438535	Micro Switch V-1A442 U/L	ES-1-18	2
6-130x	ER376435	Spark Quencher U/L 0.1µ+120 250WV	41-1-35	1
6-131x	ZW486358	Screw, round head 3x15		3
6-132x	ZW439514	Screw, binding head 3x18		1
6-133	ML316394	Operation Switch Lever	MR-112	1
6-134x	ZW270088	'E' Ring 1.9M	6-1-9	1
6-135	ZW425788	Screw, round head 3x4		3
6-136	ML316427	MR Pause Lever, w/lever B	MR-233	1
6-137	ZW217877	Pause Lever Retaining Screw	900-136	1
6-138	MZ316451	M-7 Pause Stopper	MR-116	1
6-139	ZG301061	Pause Spring 990A	4TR-138	1
6-140	ML316440	Shut-off Switch Lever	MR-234	1
6-141	ZW323728	Screw, binding head 3x5		6
6-142	ZW207314	Amp. Lever Set Screw	3A-737	1
6-143	MC399521	Counter M-470D	9-1-14	1
6-144	MB303535	Counter Belt D9x1.6	1A-617	1
6-145	MZ317406	Brake Band Guide, w/buse	MR-120	2
6-146	BL316484	AS Lever Comp.	MS,MR,MC	1
6-147	ZG260706	AS Lever Spring	4TR-118	1
6-148	ZW290294	'U' Ring 2.85M	6-1-1B	1
6-149x	MP271170	LC Pinch Roller	LC-381	1
6-150x	EJ205975	Cramp Terminal 1-SD	22-1-7	2
6-151	ZG217394	Belt Change Spring B	µB-125	1

FIG. 7 PHOTO OF TENSION RELAY P.C. BOARD (MR-558)

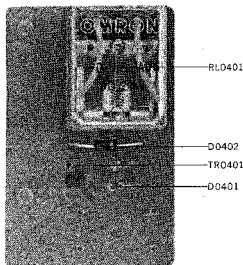

TENSION RELAY P.C. BOARD (MR-558) BLOCK

Symbol No.	Parts No.	Description	Q'ty
7-1x	BA317081	Tension Relay P.C. Board Comp. (MR-558)	1
7-TR0401	ET234808	Transistor 2SC372(Y)	1
7-D0401	E0219464	Germanium Diode IN34A	1
7-D0402	ED224526	Silicon Diode 10D1	1
7-RL0401	EP325585	Relay MY2-C-US-AD6-24V	1
7-R0401	ER212264	Carbon Resistor RD1/4 22k(J) (Stop. type)	1

FIG. 8 PHOTO OF SYS. CON. P.C. BOARD (MR-504)

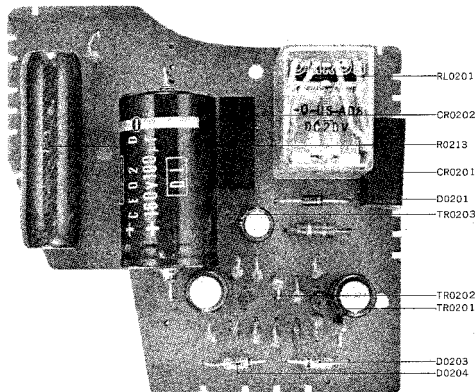

SYS. CON. P.C. BOARD (MR-504) BLOCK

Symbol No.	Parts No.	Description	Q'ty	Symbol No.	Parts No.	Description	Q'ty
8-1x	BA324088	Sys. Con. P.C. Board Comp. (MR-504)	1	Resistor, Stopper Type			
8-TR0201,2	ET398711	Transistor 2SC945(Q)(R)	2	8-R0201	ER357456	Carbon RD1/4 2.2k(J)	1
8-TR0203	ET430907	Transistor 2SC1211(C)(D)	1	8-R0202	ER336442	Carbon RD1/4 10k(J)	1
8-D0201	ED224526	Silicon Diode 10D1	1	8-R0203	ER346601	Carbon RD1/4 47k(J)	1
8-D0202	ED224550	Silicon Diode 10D4	1	8-R0204,5	ER336442	Carbon RD1/4 10k(J)	2
8-D0203,4	ED219464	Germanium Diode 1N34A	2	8-R0206,7	ER342933	Carbon RD1/4 27k(J)	2
8-CR0201	ER376424	Spark Quencher U/L	1	8-R0208	ER361642	Carbon RD1/4 47(J)	2
		0.1 μ *120 500WV	1	8-R0209	ER336442	Carbon RD1/4 10k(J)	1
8-CR0202	ER450786	Spark Quencher U/L	1	8-R0210	ER357456	Carbon RD1/4 2.2k(J)	1
		0.1 μ *120 400WV	1	8-R0211	ER316078	Solid RC1/2W 1.8k(K)	1
8-RL0201	EP316001	Relay MY4-O-US-ADR 20V	1	8-R0212	ER380711	Carbon RD1/4 220k(J)	1
				8-R0213	ER316080	Enamel RWH15G 1.5k(J)	1
Capacitor, Vertical Type							
8-C0201	EC320040	Elect. 47 μ F 16WV	1	(Term. type)			
8-C0202	EC220127	Elect. 100 μ F 16WV	1				
8-C0203,4	EC251087	Mylar 0.022 μ F(K) 50WV	2				
8-C0205	EC220127	Elect. 100 μ F 16WV	1				
8-C0206	EC316091	Elect. 100 μ F 160WV (Tub. type)	1				
8-C0207	EC316113	Elect. 47 μ F 160WV (Tub. type)	1				
8-C0208	EC308711	Mylar 0.047 μ F(K) 50WV	1				

When ordering parts, please describe Parts Number, Serial Number, and Model Number in detail.

FIG. 11 PHOTO OF NOISE REDUCTION P.C. BOARD (MS-5215)

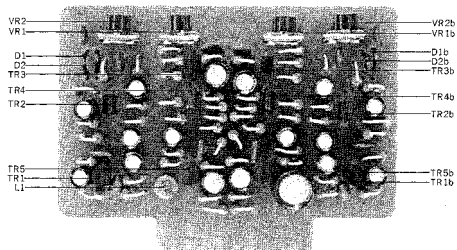

NOISE REDUCTION P.C. BOARD (MS-5215) BLOCK

Symbol No.	Parts No.	Description	Q'ty	Symbol No.	Parts No.	Description	Q'ty
11-1x	BA487405	Noise Reduction P.C. Board Comp. (MS-5215)	1			Resistor, Stopper Type	
11-TR1	ET380834	Transistor 2SC711(E)	2	11-R1	ER350100	Carbon RD1/4 68k(J)	2
11-TR1,3,4	ET234854	Transistor 2SC458LG(C)	6	11-R2	ER346601	Carbon RD1/4 47k(J)	2
11-TR5	ET380834	Transistor 2SC711(E)	2	11-R3	ER363664	Carbon RD1/4 56k(J)	2
11-D1,2	ED514721	Silicon Diode WG-59	4	11-R4	ER343078	Carbon RD1/4 2.7k(I)	2
11-L1	EO243988	Ferri Inductor FL7H 3.3MH(J)	1	11-R5	FR212477	Carbon RD1/4 3.3k(J)	2
11-VR1	EV498071	Semi-fixed Volume V10K8-1-5 1k Ω (4US)	2	11-R6	FR380711	Carbon RD1/4 220k(J)	2
				11-R7	FR212264	Carbon RD1/4 22k(J)	2
11-VR2	EV499353	Semi-fixed Volume V10K8-1-5 300k Ω	2	11-R8	ER357456	Carbon RD1/4 2.2k(J)	2
				11-R9	ER361563	Carbon RD1/4 180(J)	2
				11-R10	ER343078	Carbon RD1/4 2.7k(J)	2
				11-R11	ER211465	Carbon RD1/4 1k(J)	2
				11-R12	ER362024	Carbon RD1/4 820k(J)	2
				11-R13	ER361528	Carbon RD1/4 5.6k(J)	2
11-C1	EC320051	Elect. 10 μ F 16WV	2	11-R14	ER213030	Carbon RD1/4 5.6k(J)	2
11-C2	EC474671	VFM 10PF(K) 50WV	2	11-R15	ER361563	Carbon RD1/4 180(J)	2
11-C3	EC450527	Elect. 4.7 μ F 25WV	2	11-R16	ER212477	Carbon RD1/4 3.3k(J)	2
11-C4	EC411827	Mylar 0.0082 μ F(I) 50WV	2	11-R17	ER357456	Carbon RD1/4 2.2k(J)	2
11-C5	EC220432	Elect. 2.2 μ F 25WV	2	11-R18	ER429996	Carbon RD1/4 470k(J)	2
11-C6	EC478945	Elect. 2.2 μ F 25WV(Noiseless)	2	11-R19	FR361528	Carbon RD1/4 56k(J)	2
11-C7	EC350875	Mylar 0.001 μ F(J) 50WV	2	11-R20	ER212883	Carbon RD1/4 4.7k(I)	2
11-C8	EC220432	Elect. 2.2 μ F 25WV	2	11-R21	ER304402	Carbon RD1/4 470(J)	4
11-C9	EC380621	Mylar 0.0068 μ F(J) 50WV	2	11-R22,23	ER420322	Carbon RD1/4 36k(J)	2
11-C10	EC220994	Elect. 10 μ F 25WV	2	11-R24	ER211757	Carbon RD1/4 100k(J)	2
11-C11	EC350875	Mylar 0.001 μ F(J) 50WV	2	11-R25	ER212883	Carbon RD1/4 4.7k(J)	2
11-C12	EC220432	Elect. 2.2 μ F 25WV	2	11-R26	ER336442	Carbon RD1/4 10k(J)	2
11-C13	EC311793	Mylar 0.012 μ F(J) 50WV	2	11-R27	ER357456	Carbon RD1/4 2.2k(J)	2
11-C14	EC220994	Elect. 10 μ F 25WV	2	11-R28			
11-C15	EC220151	Elect. 100 μ F 25WV	1				

When ordering parts, please describe Parts Number, Serial Number, and Model Number in detail.

FIG. 12 PHOTO OF TONE CONTROL P.C. BOARD (MS-5028)

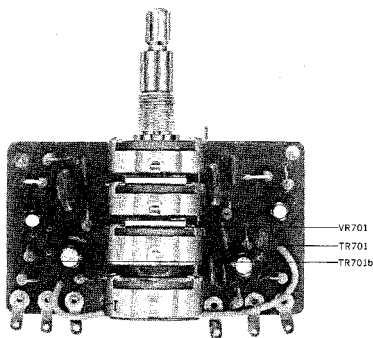

**TONE CONTROL
P.C. BOARD (MS-5028) BLOCK**

Symbol No.	Parts No.	Description	Q'ty
12-1x	BA426126	Tone Control P.C. Board Comp. (MS-5028)	1
12-TR701	ET398711	Transistor 2SC945(Q)(R)	2
12-VR701	EV424743	Dual-axial 4-throw Volume KJ-60R 50kAx4	1
Capacitor, Vertical Type			
12-C701	EC320051	Elect. 10 μ F 16WV	2
12-C702	EC220994	Elect. 10 μ F 25WV	2
12-C703	EC368335	Mylar 0.022 μ F(J) 50WV	2
12-C704	EC280683	Mylar 0.0022 μ F(J) 50WV	2
12-C705	EC438041	Mylar 0.082 μ F(J) 50WV	2
12-C706	EC329861	Mylar 0.027 μ F(J) 50WV	2
Resistor, Stopper Type			
12-R701	ER212264	Carbon RD1/4 22k(J)	2
12-R702	ER429996	Carbon RD1/4 470k(J)	2
12-R703,4	ER336442	Carbon RD1/4 10k(J)	4
12-R705	ER357456	Carbon RD1/4 2.2k(J)	2
12-R706	ER306360	Carbon RD1/4 6.8k(J)	2

FIG. 14 PHOTO OF
OSC. P.C. BOARD (MS-5025)

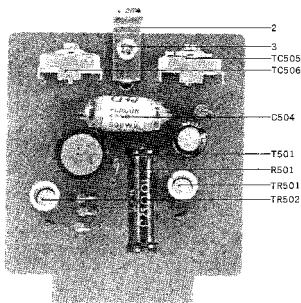
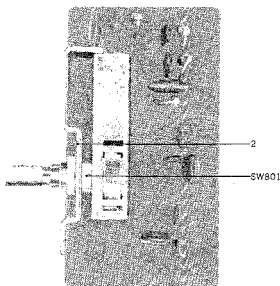

FIG. 15 PHOTO OF
EQUALIZER P.C. BOARD (MS-5027)



OSC. P.C. BOARD (MS-5025) BLOCK

Symbol No.	Parts No.	Description	Q'ty
14-1x	BA426194	OSC. P.C. Board Comp. (MS-5025)	1
14-TR501,2	ET304255	Transistor 2SC971(2)(3) (Red)	2
14-T501	EO383365	OSC. Coil OT-204	1
14-TC505,6	EC425250	Trimmer Condenser A-1F3-3	2
		70PF	
14-2	EZ425226	P.C. Board Retaining Metal	1
14-3	ZW413155	Screw, binding head 3x6	1
14-4x	ZW273756	Nut, M3	1
14-5x	ZW780401	Nut, M3	1
		Capacitor, Vertical Type	
14-C501	EC220151	Elect. 100 μ F 25WV	1
14-C502,3	EC250841	Mylar 0.01 μ F(J) 50WV	2
14-C504	EC520492	Styrol 5600PF(J) 50WV	1
		(Tab, type)	
		Resistor, Stopper Type	
14-R501	FR425237	Wire-wound 3WL 100(J) (L type)	1
14-R502,3	ER315944	Carbon RD1/4 3.3(J)	2
14-R504	ER212583	Carbon RD1/4 4.7k(J)	1
14-R505	ER304402	Carbon RD1/4 470(J)	1
14-R506	ER538536	Carbon RD1/2 3.9k(J) (Insu. type)	1

EQUALIZER P.C. BOARD (MS-5027) BLOCK

Symbol No.	Parts No.	Description	Q'ty
15-1x	BA426115	Equalizer P.C. Board Comp. (MS-5027)	1
15-SW801	ES424710	Rotary Switch SRG-R083	1
15-2	EZ424721	Equalizer Switch Base	1
		Capacitor, Vertical Type	
15-C801	EC250683	Mylar 0.0022 μ F(J) 50WV	1
15-C802	EC336216	VFM 330PF(J) 50WV	1
15-C803	EC250683	Mylar 0.0022 μ F(J) 50WV	1
15-C804	EC336216	VFM 330PF(J) 50WV	1
15-C805	EC424708	Mylar 0.0018 μ F(J) 50WV	1
15-C806	EC411827	Mylar 0.0082 μ F(J) 50WV	1
15-C807	EC368357	Mylar 0.056 μ F(J) 50WV	1
15-C808	EC424708	Mylar 0.0018 μ F(J) 50WV	1
15-C809	EC411827	Mylar 0.0082 μ F(J) 50WV	1
15-C810	EC368357	Mylar 0.056 μ F(J) 50WV	1
		Resistor, Stopper Type	
15-R801	ER213030	Carbon RD1/4 5.6k(J)	1
15-R802	ER420322	Carbon RD1/4 36k(J)	1
15-R803	ER213030	Carbon RD1/4 5.6k(J)	1
15-R804	ER420322	Carbon RD1/4 36k(J)	1

FIG. 16. PHOTO OF
SRT P.C. BOARD (MS-5029)

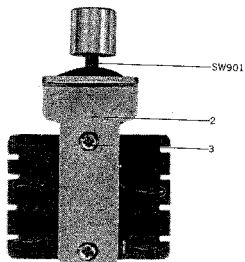

SRT P.C. BOARD (MS-5029) BLOCK

Symbol No.	Parts No.	Description	Q'ty
16-1x	BA426093	SRT P.C. Board Comp. (MS-5029)	1
16-SW901	ES426971	Push Switch UEG-62L, without Knob	1
16-2	EZ424653	SRT Holder	1
16-3	ZW375107	Screw, pan head 2.6x4	2
		Capacitor, Vertical Type	
16-C901,2	EC368357	Mylar 0.056 μ F(J) 50WV	2
16-C903,4	EC311793	Mylar 0.012 μ F(J) 50WV	2
16-C905,6	EC250841	Mylar 0.01 μ F(J) 50WV	2

FIG. 17 PHOTO OF
TRACK SELECTOR P.C. BOARD (MS-5055)

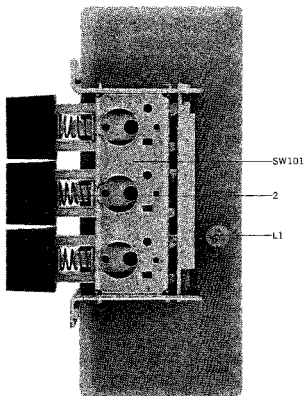

**TRACK SELECTOR
P.C. BOARD (MS-5055) BLOCK**

Symbol No.	Parts No.	Description	Q'ty
17-1x	BA426104	Track Selector P.C. Board Comp. (MS-5055)	1
17-SW101	ES448053	Push Switch SPT-034A1 3	1
17-L1	EO374681	Ferri Inductor FL7H 220 μ H(K)	1
17-2	SK383095	TUM Knob	3

When ordering parts, please describe Parts Number, Serial Number, and Model Number in detail.

FIG. 18 PHOTO OF
POWER SUPPLY P.C. BOARD (MS-5030)

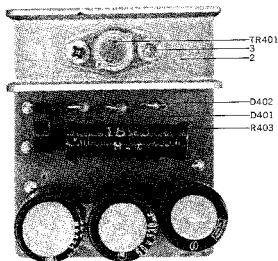

POWER SUPPLY
P.C. BOARD (MS-5030) BLOCK

Symbol No.	Parts No.	Description	Qty
18-1x	BA426150	Power Supply P.C. Board Comp. (MS-5030)	1
18-TR401	ET424833	Transistor 2SD123(Y)(G)	1
18-D401	ED329130	Silicon Diode 10DC-1 (black)	1
18-D402	ED311918	Zener Diode WZ-240	1
18-2	EZ315226	Heat-sink Plate	1
18-3	ZW413741	Screw, binding head 3x8	2
18-4x	ZW273756	Nut, M3	2
Capacitor, Vertical Type			
18-C401,2	EC403468	Elect. 330 μ F 50WV	2
18-C403	EC324538	Elect. 330 μ F 25WV	1
Resistor, Stopper Type			
18-R401	ER212883	Carbon RD1/4 4.7k(J)	1
18-R402	ER361642	Carbon RD1/4 47(J)	1
18-R403	ER413717	Wire-wound 3WL 18(J) (L type)	1

FIG. 19 PHOTO OF AMPLIFIER ASSEMBLY BLOCK

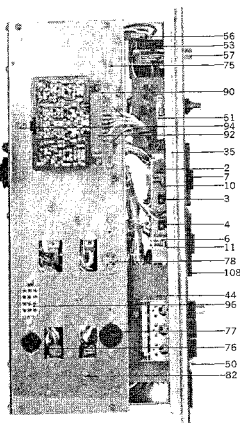
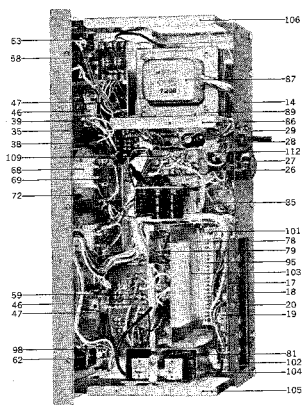

AMPLIFIER ASSEMBLY BLOCK

Ref. No.	Parts No.	Description	Schematic No.	Q'ty	Ref. No.	Parts No.	Description	Schematic No.	Q'ty
DS SWITCH BLOCK									
19-1x	BZ426082	DS Switch Block Comp.	MS	1	19-54x	MZ397394	Power Switch Table	KD-2033	1
19-2	EZ424574	DS Switch Table	MS-5002	1	19-55x	ZW371856	ISO Screw, binding head 3x5		2
19-3	ES424585	Leaf Switch A LSA-1127A (Right)	25-10-1	1	19-56	ER376413	Spark Quencher U/L 0.033u-120 500VW	41-1-37	1
19-4	ES424596	Leaf Switch B LSA-1127B (Left)	25-10-1	1	19-57	SK487697	Knob B	CG-2007	1
19-5x	ZW355601	Screw, binding head 2x5	(LF-15)	1	19-58	BA426093	SRT P.C. Board Comp. (MS-5029)		1
19-6	EZ424607	Direction Change Plate	MS-5003	2	19-59	EV487822	Volume V24N 50 kA	36-2-28	2
19-7	SB424618	Direction Change Bottom	MS-5009	2	19-60x	EV398575	Double/Vol. (FR.) DJ20A 50kZ (GX-221)	36-3-25	2
19-8x	ZW424620	Screw, pan head 3x10		2	19-61x	BA426126	Tone Control P.C. Board Comp. (MS-5028)		1
19-9x	ZG388618	Spring Washer	CS-2054	2	19-62	EJ391083	Mic. Jack 3FMJ1P	31-2-28	1
19-10	ZG388607	Function Spring B	CS-2053	2	19-63	EJ391094	Mic. Jack 2PMJ1P	31-2-27	2
19-11	ZW391206	Spring Washer B	CS-2054B	2	19-64x	EZ225180	Nylon Collar, Jack	LD-590	3
19-65x	ZW488946	Washer (Lumilar)							
REAR PANEL BLOCK									
19-12x	SP432606	Rear Panel Block Comp. (Deck)	MSD	1	19-66x	ZW375153	E Jack Nur	D9.2x18x0.25t	3
19-13x	BZ426137	Rear Panel Block Comp. (GX-221)	MSA	1	19-67x	ZW260368	Washer (Fiber) D9.2x18x0.5t		1
19-14	EZ424776	Rear Chassis B	MS-5031	1	19-68	EM487710	VU Meter KL-251A-7	(GX-225D)	46-1-38
19-15x	EZ424765	Rear Chassis A (GX-221)	MS-5031	1	19-69	EA487708	VU P.C. Board	MS-5209	2
19-16x	BZ426148	Jack Plate Block Comp.	MS	1	19-70x	EM424484	VU Meter KPM-7E (GX-221/D)	46-1-39	2
19-17	EZ373511	DPS Terminal Plate	31-1-25	1	19-71x	ZW424495	Washer (SPC) D3.1x8x1t		4
19-18	EZ424787	Jack Plate Holder	MS-5009	1	19-72	ZG290878	VU Meter Spring	DX-344	4
19-19	EJ331435	Lug Plate VB2L	33-4-4	1	19-73x	ZW348107	ISO Nut, M3		2
19-20	ZW383951	Screw, truss head 3x5(black)		5	19-74x	EL295312	No. 2 Lamp 8V 0.2A	31-5-08	1
19-21x	ZW273756	Nut, M3		5	19-75	EZ424225	Amp. Chassis	31-5-59	1
19-22x	EJ378966	Mic. Jack 2PMJ2 (GX-221)	31-2-26	2	19-76	EJ426532	4P Socket S-16303	31-1-19	1
19-23x	ZW224976	Jack Thin Washer	DX-509	2	19-77	EJ277108	5P TV-Connect-Socket	31-1-16	1
19-24x	ZW375153	E Jack Nut		2	19-78	EJ298607	4P Jack	MS-5016	1
19-25x	ES375478	Slide Switch ESD-379DU (GX-221)	25-3-25	1	19-79	EZ426576	Connector Shield		
19-26	EJ233370	Power Plug Socket S-18010	40-1-3	1	19-80x	ZW200887	Tapping Screw #2 3x6(round)		
19-27	ZW372025	ISO Screw, truss head 3x6		2	19-81	EZ411276	P.C. Board Retaining	Metal Prop	LF-5011
19-28	EZ382263	Strain Relief SR-4K-4	21-7-12	1	19-82	ZW417025	Screw, binding head 3x8, w/washer		2
19-29	EZ374894	U/L AC Cord 3M	24-3-19	1	19-83x	ED224572	Silicon Diode 5B2 (GX-221)	45-2-20	1
19-30x	EF338387	Fuse ST-2 1.5A	39-1-28	1	19-84x	EC401580	Elect., C, 2200uF 50VW (Lug type) (GX-221)	24-10-44	1
19-31x	EF424811	Fuse ST-2 2.5A (GX-221)	39-1-29	1	19-85	EJ255082	Lug Plate VB2L	33-4-16	1
19-86	EZ424260	Trans. Hanger			19-87	BT424282	Power Trans. MST-1 (Deck)	38-4-103	1
19-88x	BT424271	Power Trans. MST-3 (GX-221)			19-89	ZW200700	Tapping Screw #2 4x8 (round)		4
19-32x	BZ487214	Sub Panel Block Comp. (GX-225D)		1	19-90	EZ487080	Multi Holder (MS-2)	MS-5011	1
19-33x	BZ487236	Sub Panel Block Comp. (GX-221D)		1	19-91x	EZ424304	Multi Holder (GX-221)	MS-5017	1
19-34x	BZ487225	Sub Panel Block Comp. (GX-221)		1	19-92	EJ292961	10P Multi-Jack 500-010-005	31-4-4	2
19-35	SP487653	Sub Panel C (GX-225D)	MS-5001	1	19-93x	ZW487091	Screw, pan head 2.3x8		2
19-36x	SP424462	Sub Panel B (GX-221D)	MS-5001	1	19-94	EZ487315	NRP Holder	MS-5010	1
19-37x	SP424451	Sub Panel A (GX-221)	MS-5001	1	19-95	EJ347670	22P Multi-Jack-3 3250-022-001S	31-4-13	2
19-38	EJ331435	Lug Plate VB2L	33-4-6	1	19-96	EJ293073	12P Mate-N-Lock Plug Housing 1-480275-0	32-1-1	1
19-39	EJ255115	Lug Plate VB2L2	33-4-3	1	19-97x	EJ373634	Socket Contact 61115-1	32-1-1	12
19-40x	ER329308	Carbon/R. RDI/4 47k(J) (Insu. type)	R1.4	2	19-98	ES374051	Push Switch UEG-22CP	25-6-26	1
19-41x	ER345712	Carbon/R. RDI/4 22k(J) (Insu. type)	R1.4	2	19-99x	EZ424517	Switch Holder	MS-5006	1
19-42x	EA388674	Lamp P.C. Board (Rec.)	CS-1134	1	19-100x	ZW432843	Screw, pan head 2.6x4		1
19-43x	EL295312	No. 2 Lamp 8V 0.2A(Rec.)	24-2-8	1	19-101	ZW200665	Tapping Screw #2 3x10 (round)		4
19-44	BA426104	Track Selector P.C. Board Comp. (MS-5055)		1	19-102	EZ487203	Multi Hanger	MS-5012	1
19-45x	BZ426082	DS Switch Comp. MS		1	19-103	EZ424236	Pre-amp. Shield	MS-5014	1
19-46	ES374051	Push Switch UEG-22CP	21-5-26	2	19-104	EZ424258	OSC Shield	MS-5015	1
19-47	EZ424517	Switch Holder	MS-5006	2	19-105	EZ424326	Side Chassis A (Right)	MS-5012	1
19-48x	ZW432843	Screw, pan head 2.6x4		2	19-106	EZ424337	Side Chassis B (Left)	MS-5012	1
19-49x	ZW323728	Screw, binding head 3x5		4	19-107x	EZ411287	P.C. Board Retaining Metal	LF-5027	1
19-50	SK487675	Knob C	CG-2007	4	19-108	EZ487258	VU Meter Escutcheon A	MS-5203	2
19-51	BA426115	Equalizer P.C. Board Comp. (MS-5027)		1	19-109	EA487350	HT P.C. Board	MS-5216	1
19-52x	ZW323728	Screw, binding head 3x5		2	19-110x	BT247746	Head Phone Trans. N19-228S	38-2-11	2
19-53	ES469541	Push Switch JB-52	25-3-40	1	19-111x	ZW323728	Screw, binding head 3x5		4
19-112	MH223108	Prop						XR-226	2

When ordering Parts, please describe Parts Number, Serial Number, and Model Number in detail.

FIG. 20 PHOTO OF FINAL ASSEMBLY BLOCK

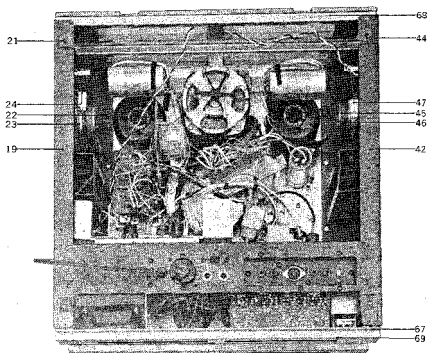

FINAL ASSEMBLY BLOCK

Ref. No.	Parts No.	Description	Schematic No.	Q'ty	Ref. No.	Parts No.	Description	Schematic No.	Q'ty
		AMP. PANEL BLOCK							
20-1x	BZ487271	Amp. Panel Block Comp. (GX-221)	1		20-49x	ZW25002	Washer (SPC) D3.1x8x0.5t		4
20-2x	BZ487282	Amp. Panel Block Comp. (GX-221D)	1		20-50x	ZW273756	Nut, M3		4
20-3x	BZ487260	Amp. Panel Block Comp. (GX-225D)	1		20-51x	MZ447996	L Metal Fitting A	MS-9039	1
20-4	SP487732	Amp. Panel D GX-221	MS-5014	1	20-52x	ZW447840	Tapping Screw #2 3x8(BR)		1
20-5x	SP487743	Amp. Panel E GX-221D	MS-5018	1	20-53	SZ424923	Side Plate A (GX-221)	MS-9060	1
20-6x	SP487721	Amp. Panel C GX-225D	MS-5018	1	20-54x	SZ424934	Side Plate B (Deck)	MS-4660	1
20-7	SM487754	Amp. Panel Name Plate	MS-5202	1	20-55x	SZ424945	Speaker Grill(GX-221)	MS-6094	1
20-8	SZ409320	Illumination Escutcheon	61-5023	1	20-56	SZ424967	Reflection Plate (GX-221)	MS-6096	1
		MECH. PANEL BLOCK			20-57x	SZ237508	Reflection Plate Retaining	Metal 1A-419	2
20-9x	BZ487462	Mech. Panel Block Comp.	MS-2-3	1	20-58x	ZW201183	Screw, truss head 3x8 (black)		2
20-10	SP487473	Mech. Panel C	MS-6094	1	20-59x	ZW425046	Screw, 3x25(truss),		1
20-11	SZ397618	Counter Escutcheon	KD-4098	1			without groove		4
20-12	SZ487440	Head Cover Table A	MS-6293	1	20-60x	ZW259593	Washer (BSP) D3.4x7.8x0.5t		4
20-13x	SZ425070	Head Cover Prop	MS-9018	2	20-61x	ZW437444	Screw, oval countersunk		5
20-14x	ZW200384	Screw, countersunk head 3x6		2	20-62x	ZW462150	Decorative Washer, M4		5
20-15	ZW425125	Screw, oval countersunk head 3x6		2					
20-16	SZ435082	Panel Ring	KD-46004	2					
		SIDE PLATE (RIGHT) BLOCK							
20-17x	BZ432461	Side Plate (Right) Block Comp. (GX-221)	1						
20-18x	BZ432527	Side Plate (Right) Block Comp. (Deck)	1						
20-19	SZ424901	Side Wall B (GX-221)	MS-6001	1					
20-20x	SZ340281	Side Wall B2 (Deck)	MS-6001	1					
20-21	ZW290250	U type Speed Nut, M4 #1 (large) 6-3-2		2					
20-22	ZW290248	U type Speed Nut, M4 #1 (small) 6-3-1		2					
20-23	SS391342	Speaker SK-2187E (GX-221) 29-5-9		1					
20-24	ER364713	Cement/R. 5W 27(K) (Wire-wound type) 35-16-1		1					
20-25x	ZW355487	Screw, binding head 3x10		4					
20-26x	ZW425002	Washer (SPC) D3.1x8x0.5t		4					
20-27x	ZW273756	Nut, M3		8					
20-28x	MZ447592	L Metal Fitting B	MS-6039	1					
20-29x	ZW447840	Tapping Screw #2 3x8(BR)		2					
20-30	SZ424923	Side Plate A (GX-221)	MS-9060	1					
20-31x	SZ424934	Side Plate B (Deck)	MS-9061	1					
20-32	SZ424945	Speaker Grill (GX-221)	MS-6094	1					
20-33	SZ424967	Reflection Plate (GX-221)	MS-6096	1					
20-34	SZ237508	Reflection Plate Retaining	Metal 1A-419	2					
20-35x	ZW201183	Screw, truss head 3x8(black)		2					
20-36	ZW425046	Screw 3x25 (truss),		4					
20-37x	ZW259593	Washer (BSP) D3.4x7.8x0.5t		4					
20-38	ZW437444	Screw, oval countersunk head 4x25		5					
20-39	ZW462150	Decorative Washer, M4		5					
		SIDE PLATE (LEFT) BLOCK							
20-40x	BZ432516	Side Plate (Left) Block Comp. (GX-221)	1						
20-41x	BZ432538	Side Plate (Left) Block Comp. (Deck)	1						
20-42	SZ424890	Side Wall A (GX-221)	MS-6001	1					
20-43x	SZ540270	Side Wall A2 (Deck)	MS-6001	1					
20-44	ZW290250	U type Speed Nut, M4 #1 (large) 6-3-2		2					
20-45	ZW290248	U type Speed Nut, M4 #1 (small) 6-3-1		2					
20-46	SS391342	Speaker SK-2187E (GX-221) 29-5-9		1					
20-47	ER364713	Cement/R. 5W 27(K) (Wire-wound type) 35-16-1		1					
20-48x	ZW355487	Screw, binding head 3x10		4					
		ASSEMBLY BLOCK							
		20-63x	SZ425024	Panel Support	MS-6008	2			
		20-64	SF487606	Sash (Right), w/pin	MS-4660	1			
		20-65	SF487528	Sash (Left), w/pin	MS-6009	1			
		20-66x	ZW323728	Screw, binding head 3x5		6			
		20-67	ZW447772	Tapping Screw #2 3x6(BR)		20			
		20-68	SZ454893	Channel A	MS-6038	1			
		20-69	SZ454904	Channel B	MS-6641	1			
		20-70x	SZ433956	Head Cover Shield	MS-6035	1			
		20-71	SC487541	Head Cover A	MS-6204	1			
		20-72	SM487563	Head Cover Name Plate	GX-221 MS-6205	1			
		20-73x	SM487574	Head Cover Name Plate	GX-221D MS-6205	1			
		20-74x	SM487552	Head Cover Name Plate	GX-225D MS-6205	1			
		20-75	SZ425160	Bottom Plate	MS-6021B	1			
		20-76	SZ377190	LM Rubber Foot	LM-404	8			
		20-77x	ZW419646	Washer (SPC) D4.5x9.8x0.5t		4			
		20-78x	ZW407772	Screw, truss head 4x1.8		8			
		20-79	ZW408418	Panel Washer	KD-6009	4			
		20-80	ZW411660	Screw, oval countersunk head 3x6		4			
		20-81	SZ425171	Upper Plate (Ceiling)	MS-6021	1			
		20-82x	ZW463037	Washer, M3 (Mountain type)		4			
		20-83x	ZW425125	Screw, oval countersunk head 3x6 (black)		4			
		20-84x	SZ425316	Change Name Plate	MS-6024	1			
		20-85x	ZW432944	Push Nut 3x10x0.3t		1			
		20-86x	ZW320265	Lock Screw	MR-646	1			
		20-87x	ZW259514	Washer (Nylon) D3.1x8x1t		1			
		20-88x	SZ488801	Back Cover A-1 (GX-221)	MS-6023	1			
		20-89x	SZ488812	Back Cover D-1 (Deck)	MS-6023	1			
		20-90x	ZW4662194	Tapping Screw #2 3x8(pan), w/washer		4			
		20-91x	ZW200643	Tapping Screw #1 4x25(truss)		4			
		20-92	SK425158	Pinch Roller Cap	MS-6020	1			
		20-93	SK487585	Mech. K ob A	MS-6095	2			
		20-94x	ZW253405	Mech. Knob Screw	7-1-46	2			
		20-95	SK476752	Pause Knob	MR-612	1			
		20-96x	ZW433001	Set Screw, hexagon socket 3x5 (cup)		1			
		20-97	SK409498	Lever Switch Knob A, B	61 5027, 6	1			
		20-98	MF271170	LC Pinch Roller	LC-333	1			
		20-99	SK487293	Equalizer Knob	MS-5206	1			
		20-100	SK487326	Volume Knob A (GX-221)	MS-5363	3			
		20-101x	ZW200766	Set Screw 3x5 (cup)		3			
		20-102	SK487337	Volume Knob B (GX-221)	MS-5364	3			
		20-103x	ZW200733	Set Screw 3x4 (cup)		3			
		20-104x	SK476111	Amp. Knob (Deck)	MR-6010	1			
		20-105	SK487697	Knob B	CG-2067	1			
		20-106	SK487675	Knob C	CG-2067	4			
		20-107	SB424618	Direction Change Botton	MS-5604	2			
		20-108	SK383095	TUM Knob	RD-A507	3			
		20-109	EZ424383	Collar, Jack	MS-9032	3			
		20-110x	EF424811	Fuse ST-2 2.5A	29-1-16	1			
		20-111x	EF394773	Fuse 2A 250V	29-1-39	1			
		20-112x	EF335387	Fuse ST-2 1.5A	29-1-26	1			
		20-113x	EF304626	Fuse ST-4 1.5A	29-1-58	1			

When ordering parts, please describe Parts Number, Serial Number, and Model Number in detail.

INDEX

Parts No.	Ref. No. & Symbol No.	Parts No.	Ref. No. & Symbol No.	Parts No.	Ref. No. & Symbol No.	Parts No.	Ref. No. & Symbol No.
BA317081	5-40	EC250683	9-C319	EC520492	14-C804	ER212681	10-R203
BA317081	7-1x	EC250683	9-C324	ED194664	7-D0401	ER212883	9-R311
BA324088	5-33	EC250683	12-C704	ED194644	8-D0203,4	ER212883	9-R320
BA324088	8-1x	EC250683	15-C801	ED219464	10-D201,2,3	ER212883	9-R320
BA334541	4-11	EC250683	15-C803	ED224526	7-D0402	ER212883	10-R207
BA426093	16-1x	EC250841	10-C210	ED224526	8-D0201	ER212883	10-R209
BA426093	19-58	EC250841	14-C502,3	ED224526	10-D204	ER212883	10-R214
BA426104	17-1x	EC250841	16-C905,6	ED224550	8-D0202	ER212883	11-R21
BA426104	19-44	EC251087	8-C0203,4	ED224572	19-R33x	ER212883	11-R26
BA426115	15-1x	EC251291	13-C605	ED329130	18-D401	ER212883	14-R204
BA426115	19-51	EC308711	8-C0208	ED511918	18-D402	ER212883	18-R401
BA426126	12-1x	EC308711	13-C610	ED514721	11-D1,2	FR113030	11-R15
BA426126	19-61x	EC311793	11-C13	EF304626	20-113x	FR113030	15-R801
BA426150	18-1x	EC311793	16-C903,4	EF338387	19-30x	FR113030	15-R801
BA426161	9-1x	EC313223	9-C318	EF363887	29-112x	FR113030	15-R801
BA426172	10-2x	EC314662	6-71	EF394773	20-111x	FR304402	11-R22,23
BA426183	13-2	EC316091	8-C0206	EF424811	19-31x	FR304402	14-R505
BA426194	14-1x	EC316113	8-C0207	EF424811	20-110x	FR306360	12-R706
BA432742	13-1x	EC320040	8-C0201	EF460653	13-F601	FR306382	9-R308
BA432760	10-3x	EC320051	9-C312	EF412413	10-C201	FR315944	14-R502,3
BA487247	10-1x	EC320051	9-C320	E1425193	13-4	ER316078	8-R0211
BA487405	11-1x	EC320051	10-C213	EJ105975	6-150x	ER316080	8-R0213
BP476550	4-1x	EC320051	10-C219	EJ323730	19-26	ER329308	19-40x
BLH26047	1-1x	EC320051	11-C1	EJ255082	19-85	FR336442	8-R202
BL136484	6-146	EC320051	12-C701	EJ255115	19-39	FR336442	8-R202,5
BL437038	3-21x	EC324538	13-C607	EJ277108	19-77	FR336442	8-R202,9
BM314741	2-1	EC324538	18-C403	EJ292981	19-92	FR336442	9-R301
BM437040	3-1x	EC329771	9-C304	EJ293062	6-42x	FR336442	9-R301
BR426075	2-3x	EC329771	9-C307	EJ293073	19-96	FR336442	9-R310
BR426036	2-2x	EC329771	9-C313	EJ298607	19-78	FR336442	9-R329
BS433787	5-1x	EC329771	9-C316	EJ299788	1-29x	ER336442	10-R202
BT247746	10-T201	EC329771	10-C205	EJ308981	1-36x	ER336442	10-R220
BT247746	19-110x	EC329771	10-C207	EJ317125	5-44x	ER336442	11-R27
BT424271	19-85x	EC329771	10-C211	EJ314335	19-19	ER336442	13-R703,4
BT424282	19-87	EC329826	10-C211	EJ314335	19-19	ER336442	13-R601
BZ248027	6-29x	EC329848	10-C206	EJ339107	6-46x	ER342933	8-R0206,7
BZ2314820	6-1x	EC329861	12-C706	FJ347670	19-95	ER342933	9-R316
BZ2426014	6-36x	EC331705	13-C602	EJ365703	5-37	ER342933	10-R208
BZ426058	6-13x	EC336216	15-C802	EJ368853	6-47x	FR343078	11-R4
BZ426082	19-1x	EC336216	15-C804	EJ373623	5-43x	FR343078	11-R11
BZ426082	19-45x	EC337487	9-C322	EJ373634	19-97x	ER345712	19-41x
BZ426137	19-13x	EC337487	13-C601	EJ378966	19-22x	ER345756	5-6x
BZ426148	19-16x	EC339377	6-67	EJ391083	19-62	ER346601	8-R0203
BZ432461	20-17x	EC350684	13-C608	EJ391094	19-63	ER346601	11-R2
BZ432516	20-40x	EC350875	11-C7	EJ425632	1-30x	ER346994	9-R309
BZ432538	20-41x	EC350875	11-C11	EM26532	19-76	ER349784	9-R309
BZ432527	20-18x	EC350840	6-68	EL295312	19-43x	ER349942	9-R313
BZ487214	19-32x	EC368335	12-C703	EL295312	19-43x	FR350100	11-R1
BZ487225	19-34x	EC368357	18-C807	EM424484	19-70x	FR352045	9-R324
BZ487236	19-33x	EC368357	18-C810	EM487710	19-68	FR357412	9-R305
BZ487260	20-3x	EC368357	16-C901,2	EO243988	9-1301	ER357456	8-R0201
BZ487271	20-1x	EC368357	9-C315	EO243988	11-L1	ER357456	8-R0210
BZ487282	20-2x	EC372148	13-C604	EO321254	10-L201	ER357456	8-R328
BZ487462	20-8x	EC379214	9-C321	EO374681	17-L1	ER357456	10-R217
EA338574	19-41x	EC379236	10-C209	EO383365	14-T501	ER357456	10-R219
EA463206	1-52x	EC380621	11-C9	EO424866	9-L302	ER357456	11-R8
EA487350	19-109	EC399690	9-C305	EO537208	1-70	ER357456	11-R18
EA487708	19-69	EC401580	19-84x	EP15461	10-LR201	ER357456	11-R28
EC220127	8-C0202	EC403468	18-C401,2	EP16601	8-RL0201	ER357456	11-R25
EC220127	8-C0205	EC404908	10-C204	EP318115	1-25	ER357456	13-R603
EC220151	10-C211	EC404908	10-C215	EP325585	7-RL0401	ER361528	9-R317
EC220151	11-C15	EC407272	9-C306	ER211465	9-R315	ER361528	11-R14
EC220151	14-C501	EC407272	9-C311	ER211465	9-R327	ER361528	11-R20
EC220364	10-C216	EC407272	9-C314	ER211465	11-R12	ER361563	11-R9
EC220432	11-C5	EC411827	11-C4	ER211757	9-R312	ER361563	11-R16
EC220432	11-C8	EC411827	15-C806	ER211757	11-R25	ER361642	8-R0208
EC220432	11-C12	EC411827	15-C809	ER211858	9-R306	ER361642	13-R602
EC220678	9-C309	EC424708	15-C805	ER211858	9-R325	ER361642	18-R402
EC220678	13-C603	EC424708	15-C808	ER211858	10-R210	ER362024	11-R13
EC220678	13-C606	EC425250	14-TC505,6	ER212264	7-R0401	ER362441	9-R307
EC220994	9-C308	EC432810	9-C302	ER212264	9-R321	ER362441	9-R319
EC220994	9-C317	EC432810	10-C202	ER212264	10-R212,13	ER363444	11-R3
EC220994	9-C323	EC438041	12-C705	ER212264	10-R215	ER364713	20-24
EC220994	10-C208	EC450055	10-C218	ER212264	10-R218	ER364713	20-47
EC220994	10-C217	EC450055	10-C220	ER212264	11-R7	ER376413	5-24x
EC220994	11-C10	EC450527	11-C3	ER212264	12-R701	ER376413	19-36
EC220994	11-C14	EC474671	11-C2	ER212477	10-R206	ER376424	8-CR0201
EC220994	12-C702	EC476945	9-C301	ER212477	11-R30	ER376435	6-69
EC233100	13-7	EC476945	10-C203	ER212477	11-R17	ER376435	6-130x
EC250604	9-C303	EC478945	11-C6	ER212681	9-R322	ER380711	8-R0212

INDEX

Parts No.	Ref. No. & Symbol No.	Parts No.	Ref. No. & Symbol No.	Parts No.	Ref. No. & Symbol No.	Parts No.	Ref. No. & Symbol No.
ER380711	10-R211	E2424653	16-2	MR437602	3-9	MZ4255755	6-48
ER380711	11-R6	E2424721	15-2	MS217192	6-105	MZ4255766	6-80
FR399723	13-R604	E2424765	19-15x	MS243404	6-101	MZ425801	6-109
ER413717	18-R403	E2424776	19-14	MS272428	6-55	MZ425902	6-81
ER420322	15-R24	E2424787	19-18	MS216721	6-4	MZ425955	5-25
ER420322	15-R802	E2425204	13-6	MS216776	6-9	MZ425946	5-34
ER420322	15-R804	E2425226	14-2	MS317362	6-51	MZ426635	4-7
ER424855	9-R302	E2426576	19-79	MS317891	1-40	MZ447592	20-28x
ER424855	10-R205	E2428700	19-90	MS342000	2-6	MZ447996	20-51x
ER425237	14-R501	E2487203	19-102	MS425373	6-40	MZ448322	3-2
ER427083	9-R304	E2487258	19-108	MS425452	6-14	SB316754	6-10
ER427083	10-R201	E2387315	19-94	MS476572	4-3	SB424618	19-7
ER427083	10-R204	HE412187	1-64	MT255420	2-5	SB424618	20-107
ER429996	10-R216	HL1317676	1-18	MT297663	2-8	SB485741	6-77
ER429996	11-R19	HL435608	1-67	MT397225	2-10	SK487541	20-71
ER429996	12-R702	HP384524	1-46	MT425970	2-4	SK383095	17-2
ER450011	9-R314	HR384513	1-59	MT386860	2-15	SK383095	20-108
ER450786	8-CR20202	HZ231884	1-73	MT495606	2-11	SK409498	20-97
ER450797	4-12	HZ298012	1-41	MT495617	2-12x	SK425158	20-92
ER477663	5-18	HZ315077	6-119	MV248117	6-24	SK476111	20-104x
ER358536	14-R506	HZ315090	6-120	MV269665	4-25	SK476752	20-95
ES316866	6-43	HZ317092	6-26	MV270066	5-15	SK487293	20-99
ES316934	5-7	HZ317632	1-14	MZ210071	6-126	SK487326	20-100
ES317531	5-35	HZ317632	6-17	MZ217271	5-16	SK487337	20-102
ES317744	1-33	HZ317687	1-19	MZ217697	6-59	SK487585	20-93
ES374051	18-166	HZ307698	4-22	MZ218125	6-96	SK487595	19-5
ES374051	19-98	HZ317700	1-23	MZ227340	6-29	SK487675	20-106
ES375478	5-22	HZ317733	1-32	MZ244113	4-9x	SK487697	19-57
ES375478	6-127	HZ318060	6-18	MZ248005	6-31	SK487697	20-105
ES375478	19-25x	HZ382667	1-49	MZ248016	6-30	SM487592	20-74x
ES424585	19-3	HZ396505	1-11	MZ248343	4-13	SM487563	20-72
ES424596	19-4	HZ396595	1-13	MZ248354	3-23	SM487574	20-73x
ES424710	15-SW801	HZ396797	1-15	MZ53113	4-10	SM487754	20-7
ES425924	5-3	HZ402390	5-2	MZ254160	3-12	SP242451	19-37x
ES426971	16-SW901	HZ425417	1-21	MZ254182	3-13	SP242462	19-36x
ES438535	6-120	HZ425430	1-9	MZ254327	3-7	SP432606	19-12x
ES448053	17-SW101	HZ425496	6-21	MZ254411	3-29	SP487473	20-10
ES469541	19-53	HZ425507	1-39	MZ256814	6-60x	SP487506	20-64
ES488935	6-122	HZ425520	1-53	MZ260662	6-94	SP487528	20-55
ET234808	7-TR0401	HZ425542	1-4	MZ273036	4-17	SP487653	19-35
ET34854	11-TR1,3,4	HZ425564	1-60	MZ273047	1-40	SP487721	20-5x
ET304255	14-TR501,2	HZ425575	1-65	MZ292364	3-20x	SP487732	20-4
ET380834	11-TR1	HZ425586	1-7	MZ296245	4-2	SP487743	20-5x
ET380834	11-TR5	HZ425597	1-6	MZ296256	4-6	SS391242	20-23
ET391138	9-TR305	HZ425643	1-69	MZ303298	1-3x	SS391342	20-46
ET391138	10-TR404	HZ425687	1-47	MZ314403	1-31x	SZ237508	20-34
ET398711	8-TR0201,2	MB303535	2-33	MZ314605	6-63	SZ237508	20-57x
ET398711	10-TR203	MB303535	6-144	MZ314673	6-65	SZ377190	20-76
ET398711	12-TR701	MB314987	2-25	MZ314897	4-15	SZ397618	10-11
ET399868	9-TR301 to 4	MB314987	6-113	MZ314998	3-26	SZ409320	20-8
ET399868	10-TR301,2	MB437703	4-24	MZ314998	6-114x	SZ424890	20-42
ET424833	18-TR401	MB439525	4-14	MZ315000	2-28	SZ424901	20-19
ET430907	8-TR0203	MC399521	6-143	MZ315000	-1-16	SZ424923	20-30
EV221850	9-VR301	MZ223108	19-112	MZ316247	3-8	SZ424933	20-53
EV221850	10-VR201	ML226258	6-76	MZ316293	3-11	SZ424934	20-31x
EV398575	19-60x	ML228868	6-98	MZ316304	3-14	SZ424934	20-54x
EV398512	10-TR302	ML314664	6-72	MZ316326	3-18	SZ424945	20-52
EV424743	2-VR701	ML314664	6-72	MZ316355	6-38	SZ424945	20-52
EV487522	19-59	ML314842	6-91	MZ316708	6-36	SZ424967	20-33
EV498071	11-VR1	ML314864	6-93	MZ316710	6-3	SZ424967	20-56
EV499353	11-VR2	ML314932	6-100	MZ316945	5-8	SZ425034	20-63x
EZ225180	19-6	ML314976	6-112	MZ316956	5-23	SZ425050	20-13x
EZ231526	18-2	ML314976	6-112	MZ316967	-1-7	SZ425160	20-75
EZ2373511	19-17	ML316394	6-133	MZ316978	-1-9	SZ425171	20-81
EZ2374894	19-29	ML316427	6-136	MZ317025	5-30	SZ425316	20-84x
EZ382263	19-28	ML316440	6-140	MZ317046	5-26	SZ433956	20-70x
EZ411276	19-81	ML317582	5-38	MZ317373	2-21	SZ435082	20-16
EZ424287	19-107x	ML334806	6-90	MZ317373	6-54	SZ454893	20-68
EZ424225	19-75	ML396810	2-24x	MZ317466	2-32	SZ454904	20-69
EZ424236	19-103	ML396810	6-118x	MZ317466	6-145	SZ487440	20-12
EZ424258	19-104	ML425340	6-38	MZ337724	3-19x	SZ488801	20-88x
EZ424260	19-84	ML425463	6-16	MZ339388	6-66x	SZ488812	20-89x
EZ424304	19-91x	ML425790	5-107	MZ427591	6-38	SZ488811	20-83x
EZ424326	19-105	ML437591	3-22	MZ373318	5-27x	SZ500261	20-20x
EZ424337	19-106	MP271170	6-149x	MZ381701	6-123	UC250536	6-57
EZ424383	20-109	MP271170	20-95x	MZ397304	19-54x	ZG206144	1-61
EZ424517	19-9x	MR269730	5-12	MZ404820	3-30x	ZG217337	3-24
EZ424517	19-47	MR269763	6-104	MZ404820	3-37	ZG217394	3-24
EZ424574	19-22	MR314785	6-87	MZ423368	6-87	ZG217394	6-151
EZ424607	19-6	MR426958	2-19	MZ425744	6-45	ZG225516	5-29

INDEX

Parts No.	Ref. No. & Symbol No.	Parts No.	Ref. No. & Symbol No.	Parts No.	Ref. No. & Symbol No.	Parts No.	Ref. No. & Symbol No.
ZG226697	6-97	ZW273914	4-23	ZW413223	5-41		
ZG255633	2-7	ZW274026	6-52x	ZW413223	6-108x		
ZG360706	6-147	ZW290248	20-21	ZW413267	6-56x		
ZG290878	19-72	ZW290248	20-45	ZW413278	6-53x		
ZG301061	6-139	ZW290250	20-21	ZW413280	4-19		
ZG303300	1-57	ZW290250	20-44	ZW413728	5-9x		
ZG314706	6-73	ZW290283	1-45	ZW413741	18-3		
ZG314818	6-89	ZW290283	2-30	ZW413998	4-21		
ZG315011	1-58	ZW290283	3-28x	ZW414044	6-50x		
ZG315011	2-29	ZW290283	5-13	ZW417025	1-5		
ZG315011	6-117	ZW290283	6-7x	ZW417025	19-82		
ZG316732	6-5	ZW290283	6-34x	ZW417137	2-27x		
ZG316765	6-12	ZW290283	6-88	ZW417137	6-115		
ZG317114	6-28	ZW290294	6-148	ZW417150	3-25		
ZG317496	2-16	ZW314717	6-74	ZW419666	20-77x		
ZG317766	1-38	ZW314728	6-75x	ZW419826	6-92x		
ZG317902	1-43	ZW314943	6-111x	ZW424056	2-17		
ZG388607	19-10	ZW316800	6-19x	ZW424056	3-16		
ZG425531	1-55	ZW317711	1-28	ZW424056	5-31		
ZG432371	6-41	ZW317801	1-35x	ZW424495	19-71x		
ZG437253	6-35	ZW317913	1-44	ZW424620	19-8x		
ZG455692	6-106	ZW3211298	5-28x	ZW425002	20-26x		
ZW200384	20-14x	ZW322525	6-6x	ZW425002	20-49x		
ZW200417	1-37	ZW323728	1-66	ZW425046	20-36		
ZW200441	6-27	ZW323728	1-72	ZW425046	20-59x		
ZW200643	20-91x	ZW323728	2-31x	ZW425125	20-15		
ZW200665	19-101	ZW323728	4-26x	ZW425125	20-83x		
ZW200687	6-70x	ZW323728	6-44x	ZW425788	6-79		
ZW200687	13-3	ZW323728	6-62x	ZW425788	6-135		
ZW200687	19-80x	ZW323728	6-110	ZW425981	2-14x		
ZW200700	19-89	ZW323728	6-141	ZW425992	2-18		
ZW200733	20-103x	ZW323728	19-49x	ZW426622	1-50		
ZW200766	20-101x	ZW323728	19-52x	ZW427026	3-15		
ZW201183	20-55x	ZW323728	19-111x	ZW427088	6-125x		
ZW201183	20-58x	ZW323728	20-66x	ZW432347	6-75x		
ZW201475	1-48	ZW325056	13-5	ZW432663	1-42		
ZW201745	3-6	ZW330412	6-82x	ZW432674	1-17		
ZW202116	6-64x	ZW330423	6-83x	ZW432685	1-24		
ZW202116	6-95x	ZW330434	6-84x	ZW432696	1-34		
ZW202252	1-16	ZW330445	6-85x	ZW432753	6-25		
ZW202691	1-54	ZW332065	20-86x	ZW432843	19-48x		
ZW203016	3-10	ZW336868	1-62	ZW432843	19-100x		
ZW207314	5-39	ZW340672	1-68	ZW432944	6-8		
ZW207314	6-142	ZW344463	6-121x	ZW432944	20-85x		
ZW217877	6-137	ZW345914	1-56	ZW433003	20-96x		
ZW224976	19-23x	ZW348107	5-5x	ZW437444	20-38		
ZW228025	3-3x	ZW348107	19-73x	ZW437444	20-61x		
ZW228036	3-4x	ZW355487	20-25x	ZW439514	6-132x		
ZW228194	3-5x	ZW355487	20-48x	ZW440291	6-128		
ZW231805	6-22	ZW355601	19-5x	ZW447208	4-4		
ZW244710	4-8	ZW371856	5-23	ZW447772	20-67		
ZW253405	20-94x	ZW371856	19-55x	ZW447840	20-29x		
ZW257477	1-20	ZW372025	19-27	ZW447840	20-52x		
ZW259514	20-87x	ZW373577	4-5x	ZW450753	1-27		
ZW259593	20-37x	ZW375107	16-3	ZW460157	5-4x		
ZW259593	20-60x	ZW375153	19-24x	ZW462150	20-39		
ZW259630	6-11x	ZW375153	19-66x	ZW462150	20-62x		
ZW259885	6-23	ZW383343	6-20	ZW462194	20-90x		
ZW259942	5-11x	ZW383951	19-20	ZW463037	20-82x		
ZW259975	6-102x	ZW384131	5-36	ZW486358	6-131x		
ZW260054	3-27x	ZW384840	1-74	ZW487091	19-93x		
ZW260054	6-15x	ZW388618	19-9x	ZW487776	20-78x		
ZW260087	6-99	ZW391206	19-11	ZW488946	19-65x		
ZW260144	6-33x	ZW392681	4-16	ZW516655	2-20		
ZW260368	19-67x	ZW393232	4-10	ZW780401	14-5x		
ZW270088	1-21	ZW396786	1-20	ZW861344	6-32x		
ZW270088	2-9	ZW403312	1-51				
ZW270088	6-42x	ZW408418	20-79				
ZW270088	6-134x	ZW411660	20-80				
ZW272395	3-17	ZW413155	14-3				
ZW273688	6-58x	ZW413188	1-8x				
ZW273756	14-4x	ZW413188	2-22x				
ZW273756	18-4x	ZW413188	5-32				
ZW273756	19-21x	ZW413188	6-103				
ZW273756	20-27x	ZW413201	4-22				
ZW273756	20-50x	ZW413201	5-14				
ZW273778	1-12	ZW413201	6-49x				
ZW273778	2-13x	ZW413223	1-26				
ZW273778	6-124x	ZW413223	1-71				
ZW273881	1-63	ZW413223	5-20				

SECTION 3

SCHEMATIC DIAGRAM

1. GX-225D SCHEMATIC DIAGRAM
2. GX-221 SCHEMATIC DIAGRAM
3. GX-221D SCHEMATIC DIAGRAM

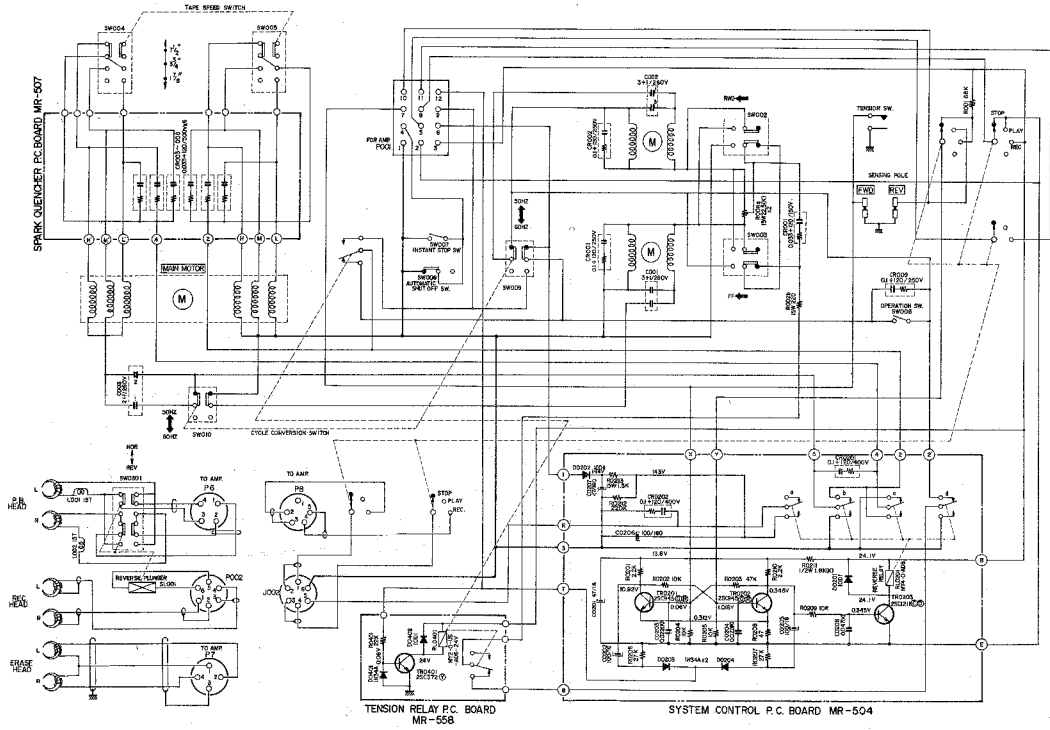

NOTE
 UNLESS OTHERWISE SPECIFIED
 ALL INDICATORS IN D. (PARTS)
 ALL CAPACITORS IN P. (SCHW.2)

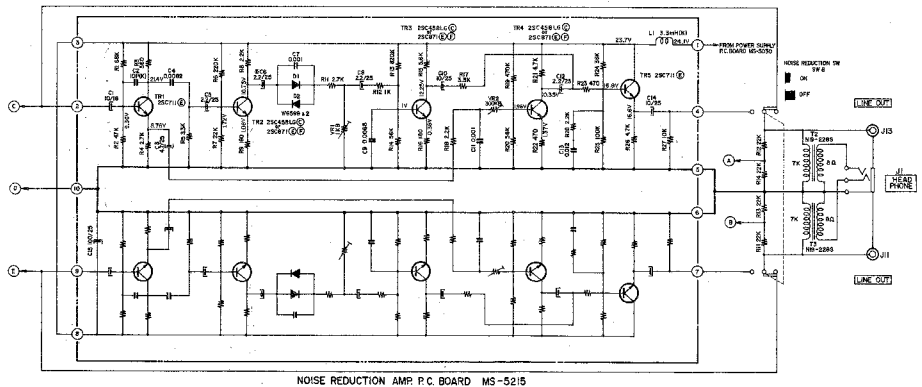
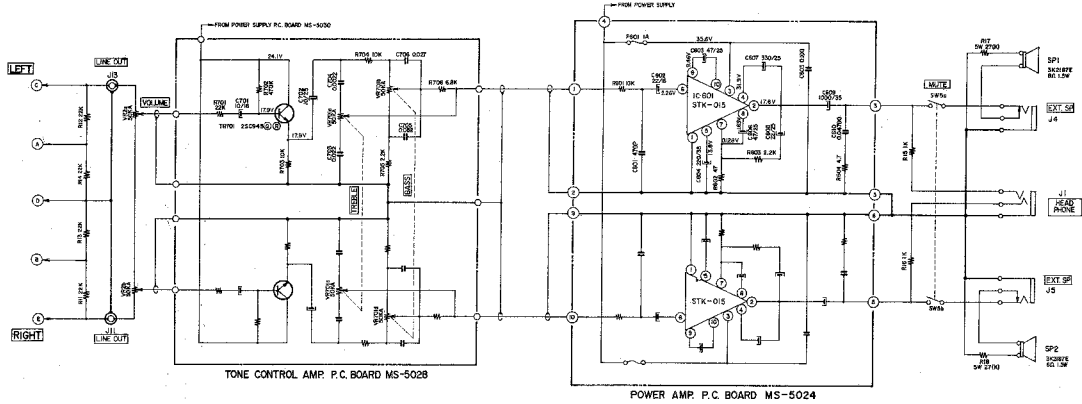

NOISE REDUCTION AMP P.C. BOARD MS-5215

NOTE
 UNLESS OTHERWISE SPECIFIED
 ALL RESISTORS IN Ω, K, M, W, UJ
 ALL CAPACITORS IN P, N, μF, V
 X MARK INDICATES LOW LEAKAGE CAPACITOR.