

SERVICE MANUAL
PARTS LIST 
AKAI STEREO TAPE DECK
MODEL GX-630D
ALSO APPLICABLE TO MODEL GX-630DB

GX-630D

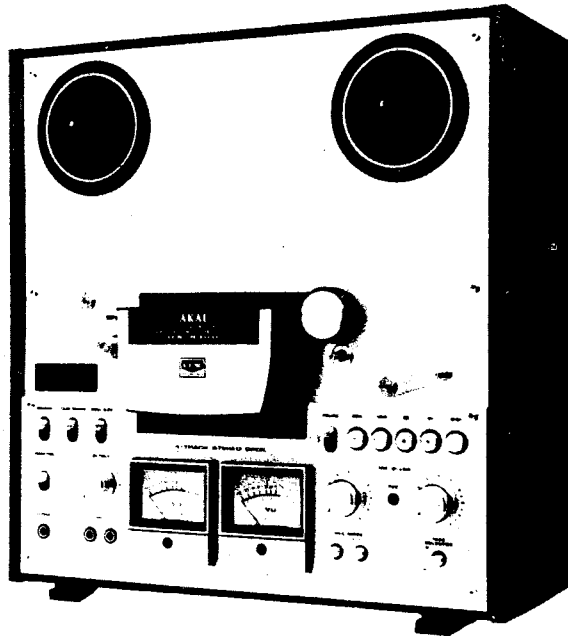

AKAI STEREO TAPE DECK

MODEL GX-630D

ALSO APPLICABLE TO MODEL GX-630DB STEREO TAPE DECK

SECTION 1	SERVICE MANUAL	1
SECTION 2	PARTS LIST	25

SECTION 1

SERVICE MANUAL

TABLE OF CONTENTS

I.	SPECIFICATIONS	2
II.	DISMANTLING OF UNIT	4
III.	ARRANGEMENT OF PRINCIPAL PARTS	5
IV.	MECHANISM ADJUSTMENT	6
	1. POSITION ADJUSTMENT OF BRAKE SOLENOID SL-2	6
	2. BRAKE TENSION ADJUSTMENT	6
	3. POSITION ADJUSTMENT OF PINCH ROLLER SOLENOID SL-1	7
	4. PINCH ROLLER PRESSURE ADJUSTMENT	7
	5. CAPSTAN SHAFT LOOSE PLAY ADJUSTMENT	7
	6. IMPEDANCE ROLLER LOOSE PLAY ADJUSTMENT	7
	7. TAPE GUIDE HEIGHT ADJUSTMENT	8
	8. REEL TABLE HEIGHT ADJUSTMENT	9
	9. INSTALLATION POSITION ADJUSTMENT OF JOINT B	9
V.	HEAD ADJUSTMENT	10
VI.	AMPLIFIER SYSTEM ADJUSTMENT	12
	1. D.C POWER SUPPLY VOLTAGE ADJUSTMENT	12
	2. TAPE SPEED ADJUSTMENT	12
	3. RECORDING AND PLAYBACK AMPLIFIER ADJUSTMENT (GX-630D)	13
	4. RECORDING AND PLAYBACK AMPLIFIER ADJUSTMENT (GX-630DB)	14
	5. DOLBY NOISE REDUCTION ADJUSTMENT (GX-630DB)	15
VII.	D.C RESISTANCE OF VARIOUS COILS	16
VIII.	CLASSIFICATIONS OF VARIOUS P.C BOARDS	17
	1. P.C BOARD INTERCHANGEABILITY CHART	17
	2. COMPOSITE VIEWS OF VARIOUS P.C BOARD	17

For basic adjustments, measuring methods, and operating principles, refer to GENERAL OPERATING PRINCIPLES AND ADJUSTMENTS.

I SPECIFICATIONS

An asterisk next to a figure indicates the minimum guaranteed performance.

TRACK SYSTEM		4 track 2 channel stereo/monaural system
TEPE SPEED		7-1/2 and 3-3/4 ips $\pm 0.7\%$ *7-1/2 and 3-3/4 ips $\pm 1.0/-1.5\%$
WOW AND FLUTTER		Less than 0.06% WRMS at 7-1/2 ips Less than 0.09% WRMS at 3-3/4 ips *Less than 0.10% RMS at 7-1/2 ips *Less than 0.15% RMS at 3-3/4 ips
TOTAL WOW AND FLUTTER		*Less than 0.12% RMS at 7-1/2 ips *Less than 0.18% RMS at 3-3/4 ips
FREQUENCY RESPONSE		30 to 25,000 Hz ± 3 dB at 7-1/2 ips 30 to 19,000 Hz ± 3 dB at 3-3/4 ips (with AKAI LN-150-7 Tape) *30 to 22,000 Hz ± 3 dB at 7-1/2 ips *30 to 18,000 Hz ± 3 dB at 3-3/4 ips
HARMONIC DISTORTION		Less than 0.5%
TOTAL HARMONIC DISTORTION		*Less than 1.5%
SIGNAL TO NOISF RATIO		Better than 50 dB
TOTAL SIGNAL TO NOISE RATIO		*Better than 47 dB
OUTPUT	LINE HEADPHONE	*0.775V (0 dBm ± 1.0 dB) 30 mV at 8 ohm At playback of a 700 Hz "0" VU pre-recorded test tape. (Output Volume at maximum)
INPUT	MIC LINE	More than 0.25 mV/10 k ohm More than 70 mV/150 k ohm At "0" VU output. (Recording Volume at maximum)
DIN INPUT/OUTPUT		0.25 mV/0.5V
RECORDING/PLAYBACK LEVEL		*0.775V (0 dBm ± 1.5 dB)
CROSS TALK		Better than 45 dB, stereo Better than 55 dB, monaural
ERASE RATIO		Better than 70 dB
RECORDING BIAS FREQUENCY		100 kHz $\pm 5\%$
BIAS LEAK		Better than -30 dB (GX-630D) Better than -50 dB (GX-630DB)
HIGH FREQUENCY DEVIATION		Within 3 dB At playback of an 8,000 Hz 3-3/4 ips pre-recorded tape at 7-1/2 ips
RECORDING TIME		180 min stereo recording at 7-1/2 ips, using a 3,600 ft tape.
F.FWD AND RWD TIME		Approximately 2 min and 40 sec at 50 Hz, using a 3,600 ft tape.
MOTOR	MAIN MOTOR REEL MOTOR	2 speed AC servo control outer rotor motor Type: SCM2-24KJ 4 pole Revolutions: 615 rpm at 7-1/2 ips (19 cm/sec) 307.5 rpm at 3-3/4 ips (9.5 cm/sec) 6 pole eddy current outer-rotor motor Type: 24XO-TD Revolutions: 930 rpm at 50 Hz 1,120 rpm at 60 Hz
HEAD	ERASE HEAD RECORDING HEAD PLAYBACK HEAD	Type: E4-260 Gap: double gap Impedance: 210 ohm $\pm 10\%$ at 100 kHz D.C Resistance: 2 ohm Type: R4-200 Gap: 4 micron Impedance: 1,870 ohm at 100 kHz D.C Resistance: 8 ohm Type: P4-202 Gap: 1.7 ± 0.5 micron Impedance: 1,400 ohm at 1 kHz D.C Resistance: 268 ohm

TRANSISTOR & FET	2SA564(Q)(R) ... 1(5) 2SC458(C) ... 0(12) 2SC458LG(C) ... 16(32) 2SC711(F)(G) ... 2(2) 2SC945L(Q)(P) ... 22(22)	2SC1247A(B)(V) ... 2(2) 2SD361(D ₁)(D ₂) ... 1(1) TIP47 ... 1(1) 2SK30A(GR) ... 0(4)
DIODE	1N34A ... 2(6) 1N4001 ... 4(4) 1N4004 ... 6(6) 1S1588 ... 1(1) 1S2473 ... 21(21) 1S2473VE ... 16(28)	10D2 ... 4(4) WZ075 ... 2(2) WZ085 ... 0(4) WZ192 ... 1(1) RD5A(M) ... 1(1)
POWER REQUIREMENT AND CONSUMPTION	100 to 240V AC 50/60 Hz, 90W (Universal Models) 220V AC 50 Hz, 100W (CEE Models) 120V AC 60 Hz, 90W (CSA Models) 100V AC 50/60 Hz, 70W (JPN Models)	
DIMENSIONS	465(H) x 440(W) x 240(D) mm (18.3" x 17.4" x 9.4") Dimensions include all protruding parts.	
WEIGHT	GX-630D: 19 kg (41.8 lbs) GX-630DB: 19.5 kg (42.9 lbs)	

- NOTES:**
1. Specifications determined with SCOTCH #211 Tape unless otherwise noted.
 2. Specifications subject to change without notice.
 3. The numbers shown in parentheses in Items TRANSISTOR & FET and DIODE are applicable to Model GX-630DB.

II DISMANTLING OF UNIT

In case of trouble, etc. necessitating disassembly, please disassemble in the order shown in photographs. Reassemble in reverse order.

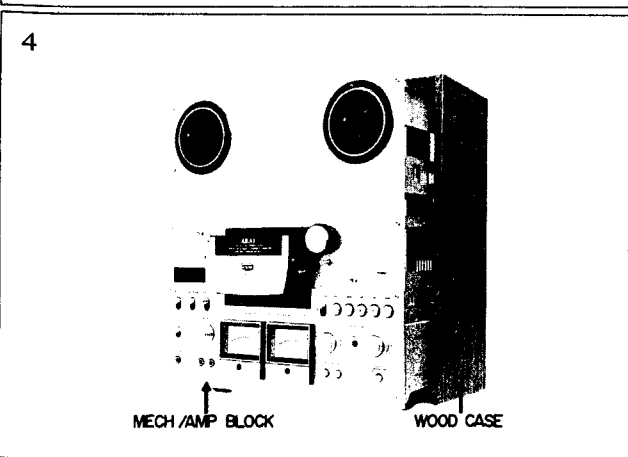
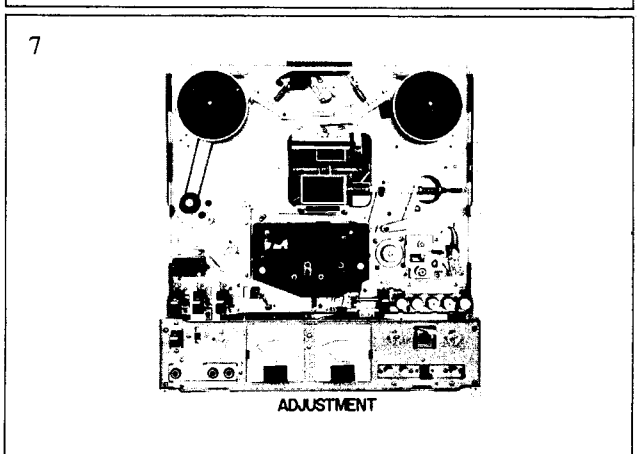
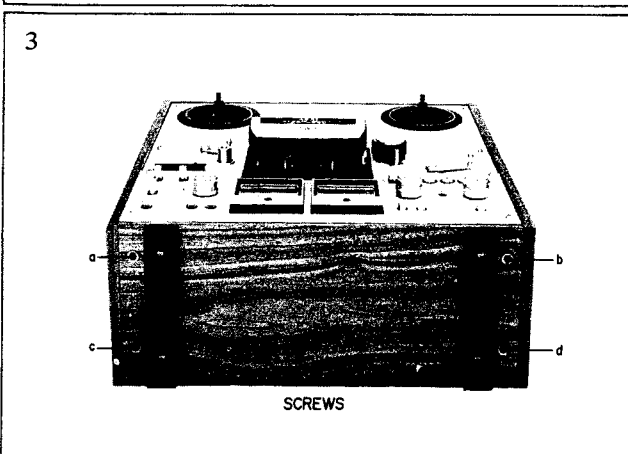
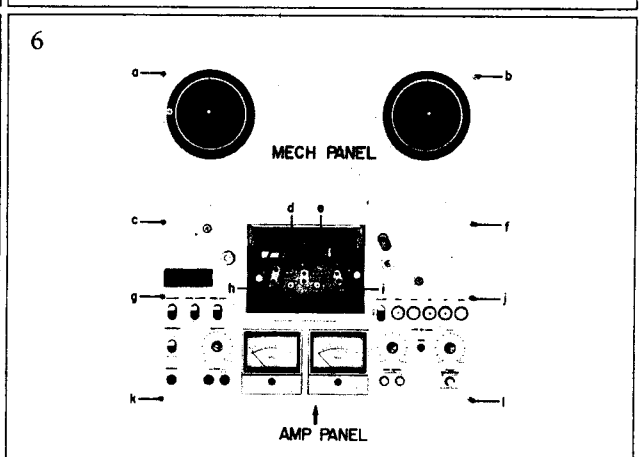
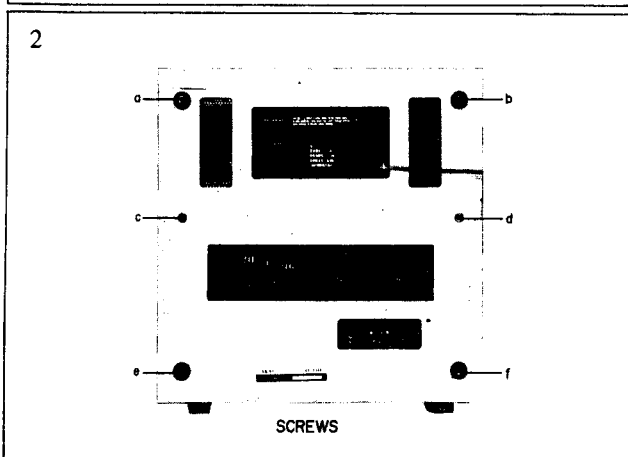
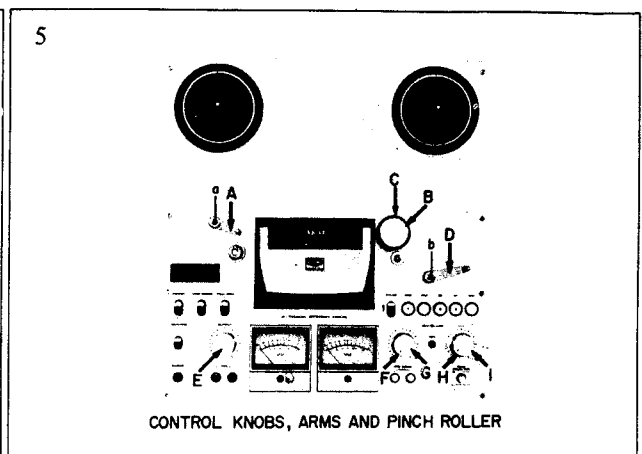
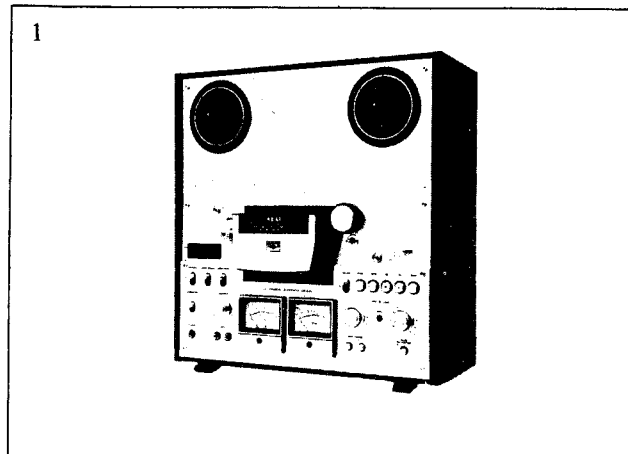

III ARRANGEMENT OF PRINCIPAL PARTS

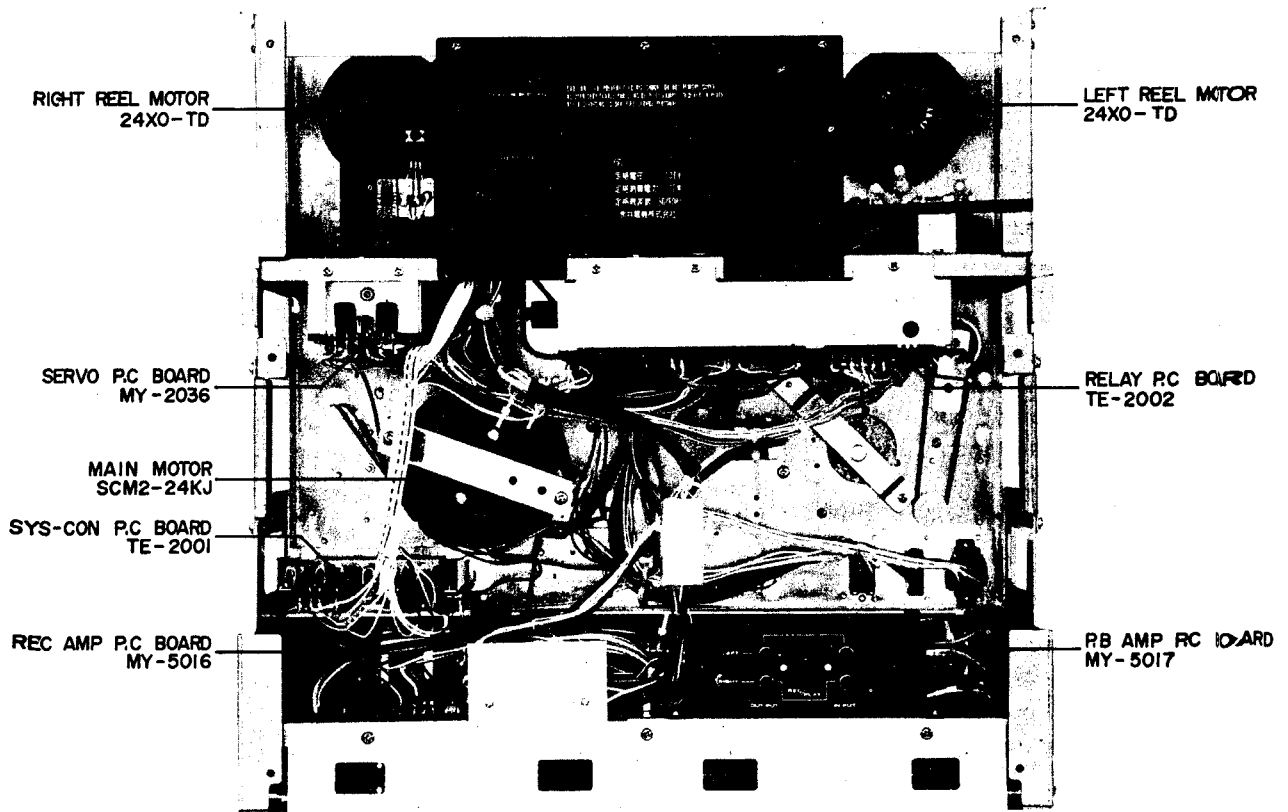
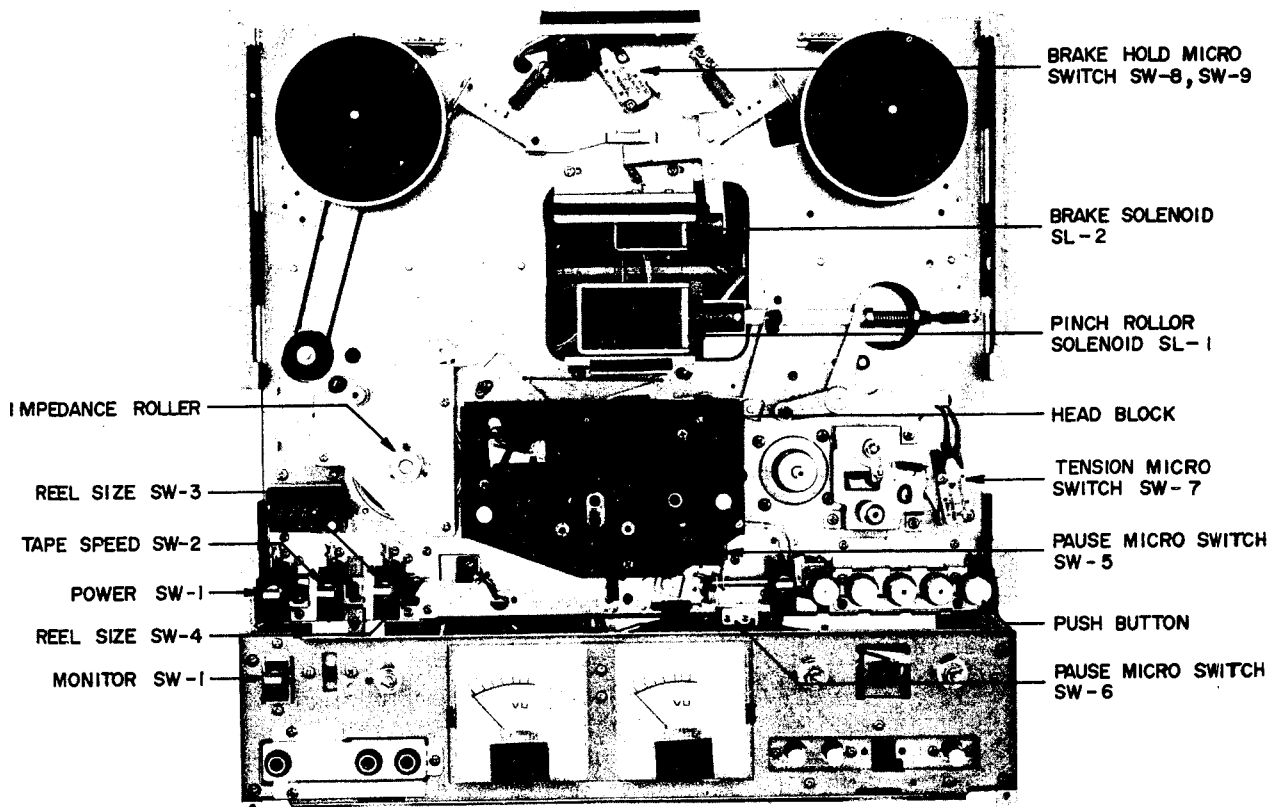

IV MECHANISM ADJUSTMENT

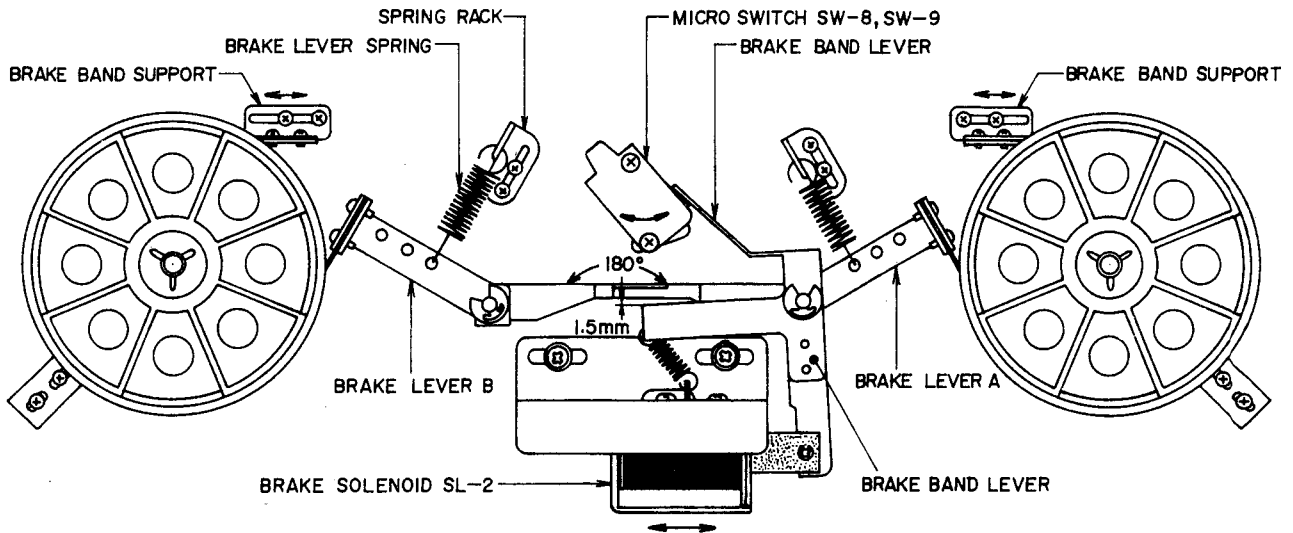

Fig. 1

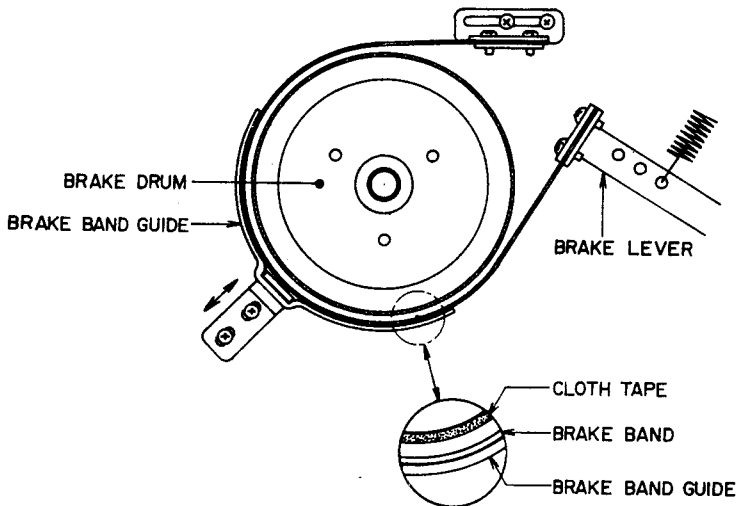

Fig. 2

1. POSITION ADJUSTMENT OF BRAKE SOLENOID SL-2 (Refer to Figs. 1, 2)

- 1) Adjust left/right Brake Band Support positions so that at stop mode, Brake Lever A and Brake Lever B display 180° angle relativity.
- 2) Under the conditions described in 1) above, adjust installation angle position of Microswitches SW-8 and SW-9 so that the clearance between the brake lever and brake band lever is 1.5 mm.
- 3) Adjust installation position of the Brake Solenoid so that at playback mode, the brake band separates from the brake drum.

2. BRAKE TENSION ADJUSTMENT (Refer to Figs. 1, 2)

- 1) Adjust installation position of the Spring Rack so that brake tension is 500g.
- 2) After brake tension adjustment, adjust installation position of the Brake Band Guide so that at all modes except stop mode, the brake band completely separates from the cloth tape on the brake drum.

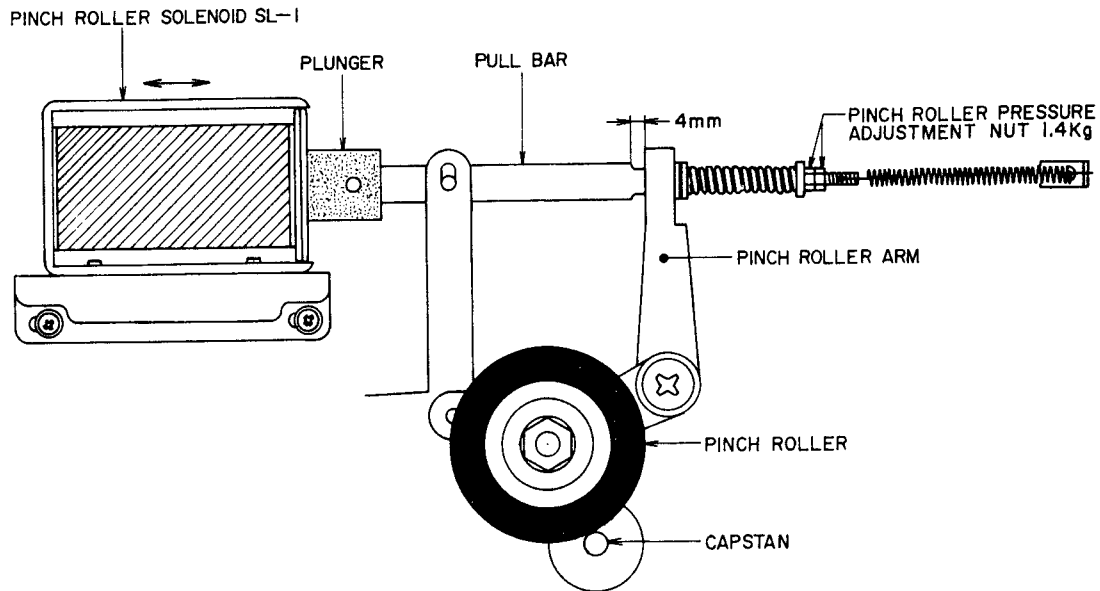

Fig. 3

3. POSITION ADJUSTMENT OF PINCH ROLLER SOLENOID SL-1 (Refer to Fig. 3)

- 1) Insert a 4 mm thickness gauge (A U type washer can be substituted) between the Pull Bar and Pinch Roller Arm.
- 2) Set the deck to playback mode, and fix Pinch Roller Solenoid at position at which pinch roller begins to rotate.

4. PINCH ROLLER PRESSURE ADJUSTMENT (Refer to Fig. 3)

Adjust Pinch Roller Pressure Adjustment Nut so that pinch roller pressure is 1.4 kg.

NOTE: To measure pinch roller pressure, pull the pinch roller away from capstan with a spring gauge and gently return. Spring Gauge indication, at the time the pinch roller contacts the capstan and the capstan begins to rotate, should be 1.4 kg.

5. CAPSTAN SHAFT LOOSE PLAY ADJUSTMENT (Refer to Fig. 4)

Adjust to obtain a clearance of 0.1 mm between the Capstan Shaft and Thrust Support Angle.

6. IMPEDANCE ROLLER LOOSE PLAY ADJUSTMENT (Refer to Fig. 5)

Adjust Screws A and B so that impedance roller loose play is 0.1 mm.

NOTE: Confirm that the screws are tight following this adjustment.

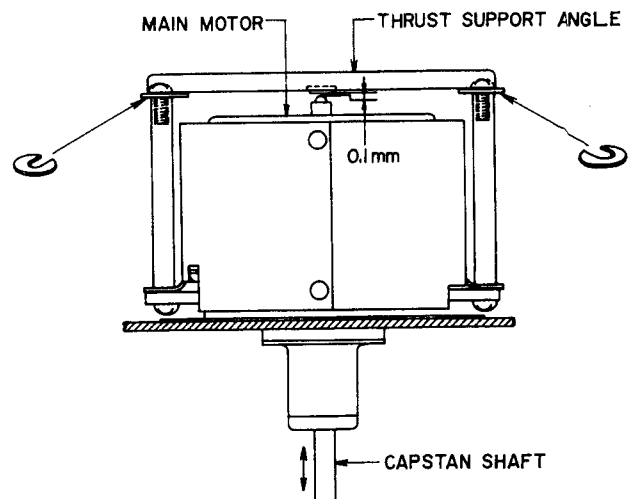

Fig. 4

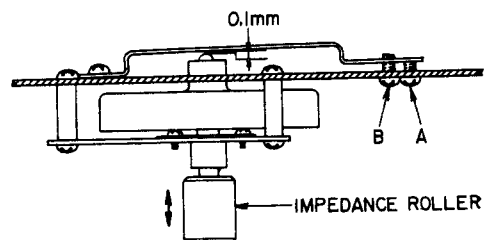
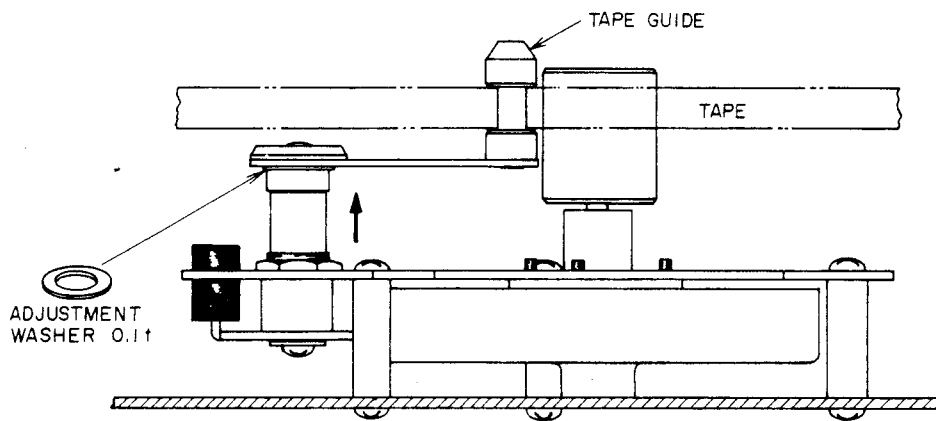
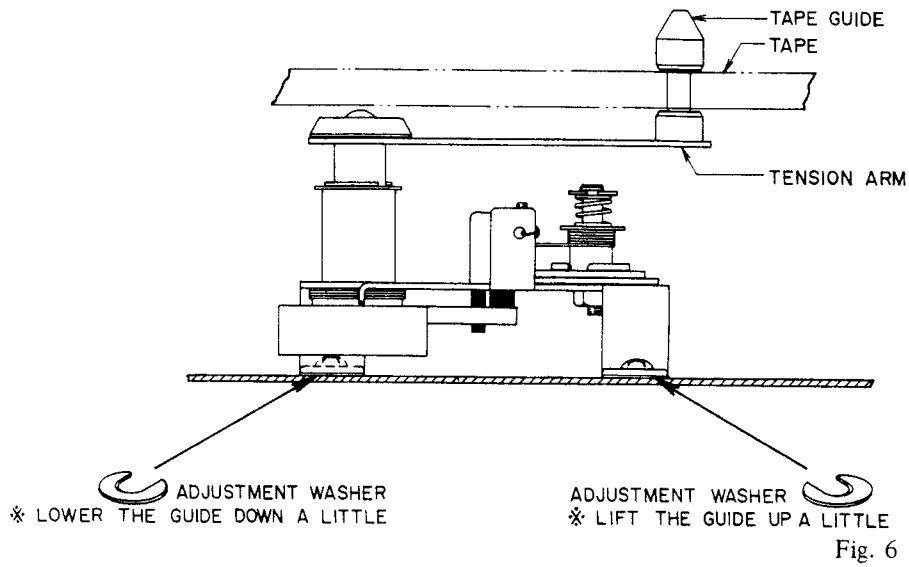

Fig. 5



7. TAPE GUIDE HEIGHT ADJUSTMENT (Refer to Figs. 6, 7)

Adjust tape guide height so that the tape does not curl between the tape guide and guides on head base.

NOTE: As left and right tape guide height adjustment methods are different, be sure to refer to Figs. 6, and 7.

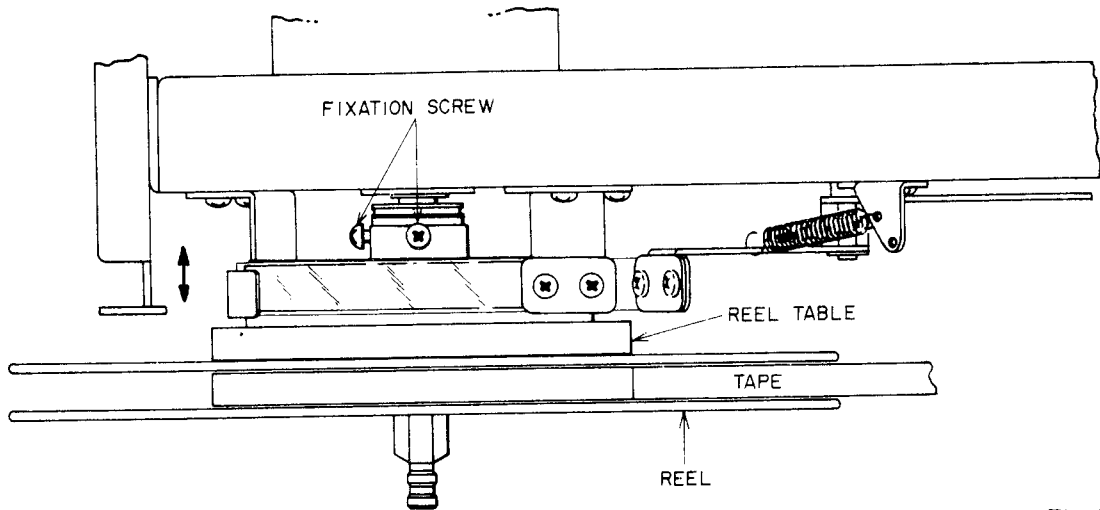

Fig. 8

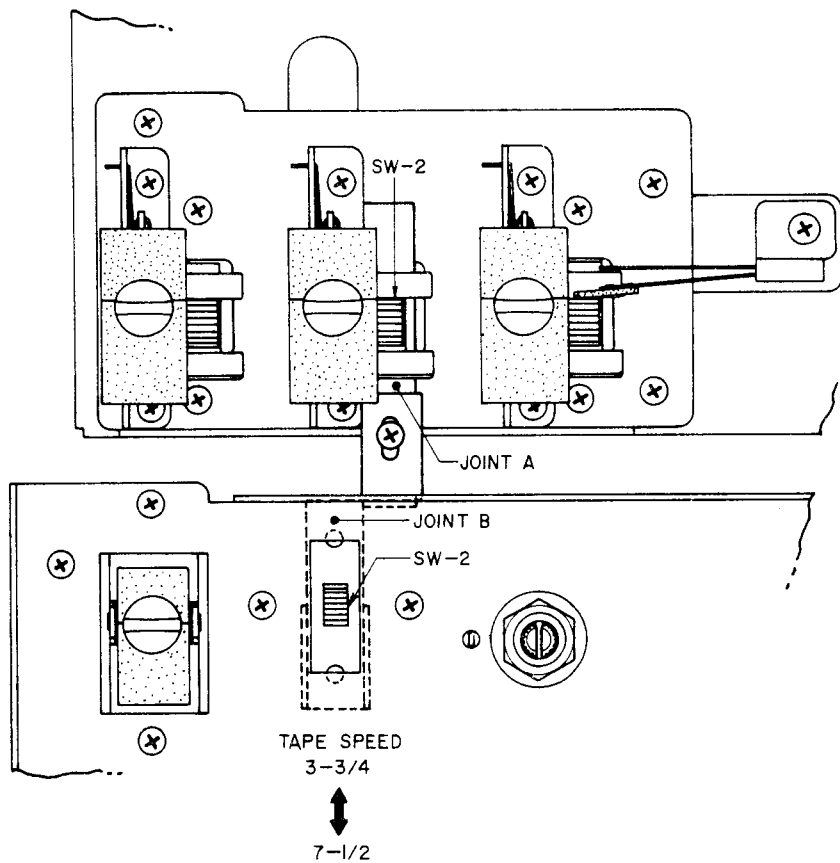

Fig. 9

8. REEL TABLE HEIGHT ADJUSTMENT (Refer to Fig. 8)

Load a tape and adjust reel table height so that at both F.FWD and RWD modes, the tape winds on the center of the reel hub.

NOTE: Tape should wind on center of reel hub regardless of type reel used.

9. INSTALLATION POSITION ADJUSTMENT OF JOINT B (Refer to Fig. 9)

Adjust installation position of Joint B so that when tape speed is changed, Slide Switch SW-2 and Equalizer Change Slide Switch SW-2 mounted on the amplifier front chassis display link-motion for proper switching.

V HEAD ADJUSTMENT

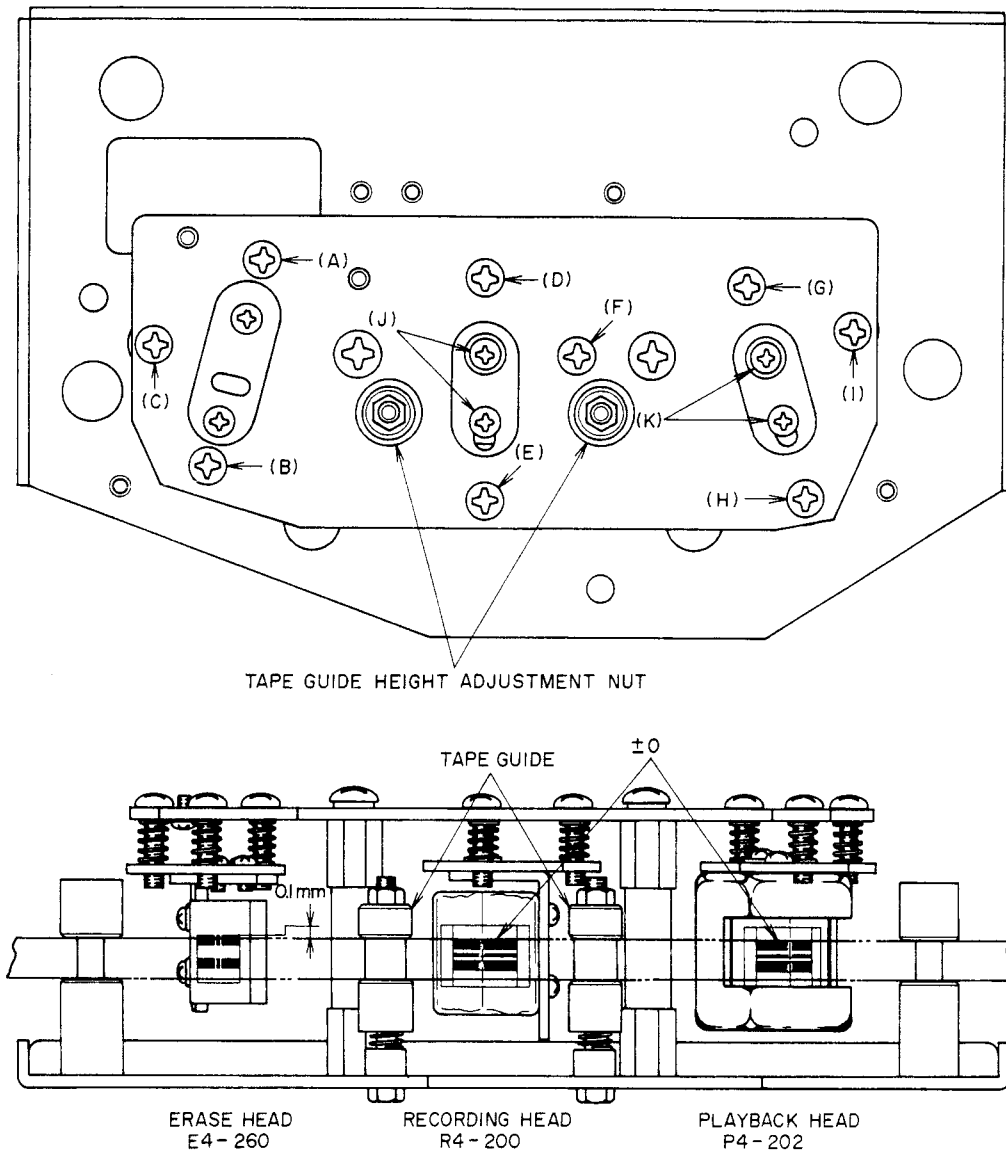

Fig. 10

- NOTES:**
1. As perfect head adjustments are vital to tape deck performance, be sure that these adjustments are carried out properly.
 2. Be careful not to use a magnetized driver or other magnetized tools in the vicinity of the heads.
 3. Use only new tape as level variation is likely to occur when using old tape.
 4. Demagnetize heads with head demagnetizer before and after head adjustment.
 5. Set tape speed to 7-1/2 ips except in steps 7 and 8.
 6. Refer to Fig. 10.

Step	Adjustment Item	Test Tape Supply Signal	MODE	Adjustment Point	Remarks
1	Tape Guide height Adjustment	Optional	PLAY	Tape Guide Height Adjustment Nut	Adjust so that tape does not twist between tape guides on head base.
2	Erase Head Height Adjustment	Optional	PLAY	(A)(B)(C)	Upper edge of channel 1 head core is 0.1 mm higher than upper edge of tape.
3	Recording Head Height Adjustment	Optional	PLAY	(D)(E)(F)	Upper edges of channel 1 head core and tape are the same height.
4	Playback Head Height Adjustment	Optional	PLAY	(G)(H)(I)	Upper edges of channel 1 head core and tape are the same height.
5	Playback Head Azimuth Alignment Adjustment	8,000 Hz 3-3/4 ips Test Tape	PLAY	(I)	Maximum output, both channels.
6	Playback Head Gap Alignment Adjustment	8,000 Hz 3-3/4 ips Test Tape	PLAY	(K)	Adjust head gap surface so that there is no change in output level when tension is applied to the supply reel side.
7	Recording Head Azimuth Alignment Adjustment	SCOTCH #211 Tape 15,000 Hz -20 dBm	REC	(F)	Maximum output, both channels.
8	Recording Head Gap Alignment Adjustment	SCOTCH #211 Tape 15,000 Hz -20 dBm	REC	(J)	Adjust head gap surface so that there is no change in output level when tension is applied to the supply reel side.

Chart 1

VI AMPLIFIER SYSTEM ADJUSTMENT

1. D.C POWER SUPPLY VOLTAGE ADJUSTMENT (Refer to Fig. 11)

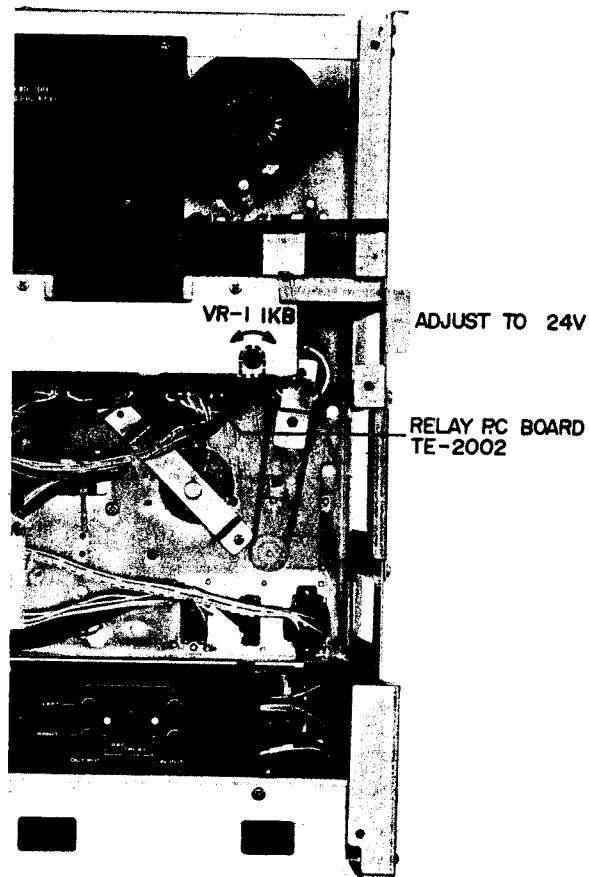

Fig. 11

2. TAPE SPEED ADJUSTMENT (Refer to Fig. 12)

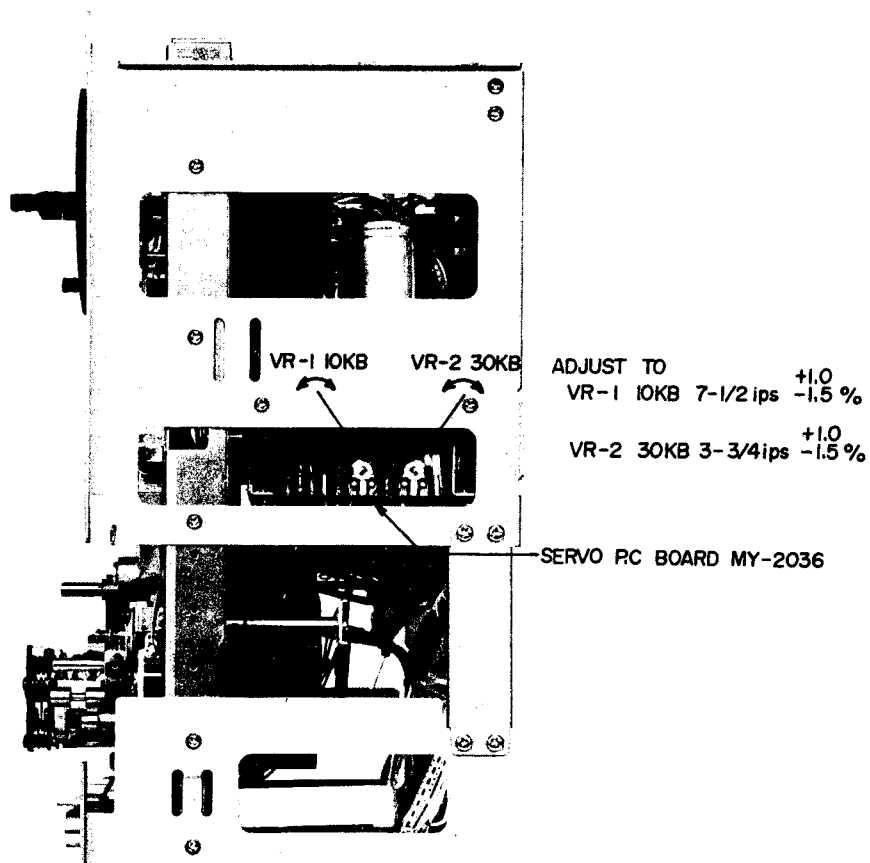

Fig. 12

3. RECORDING AND PLAYBACK AMPLIFIER ADJUSTMENT (Model GX-630D)
 (Refer to Fig. 13)

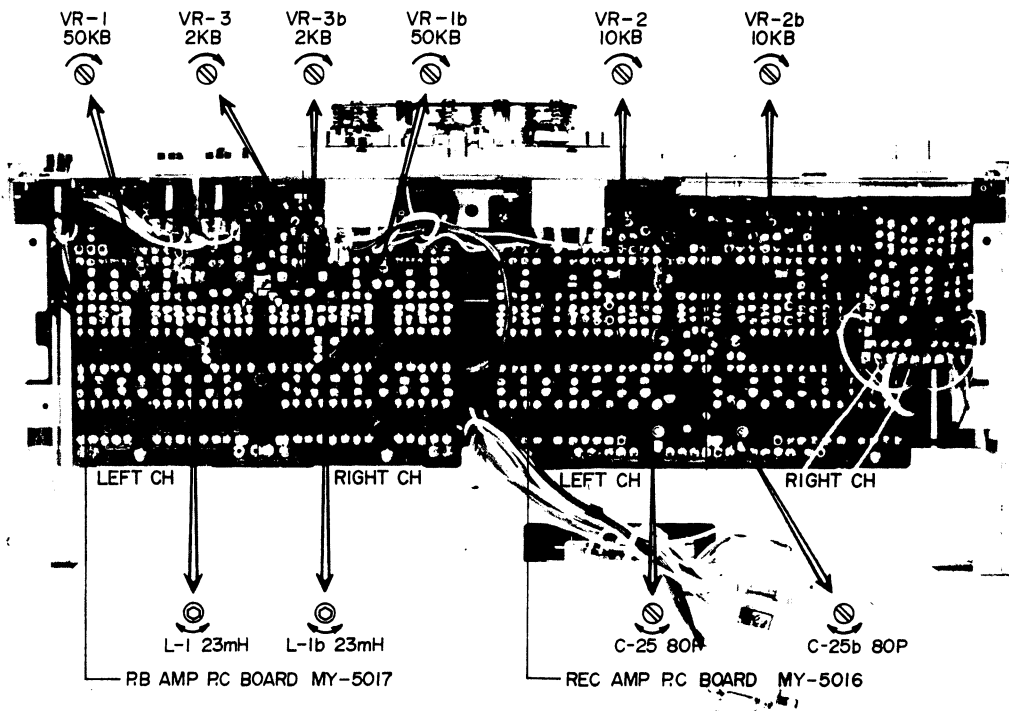

Fig. 13

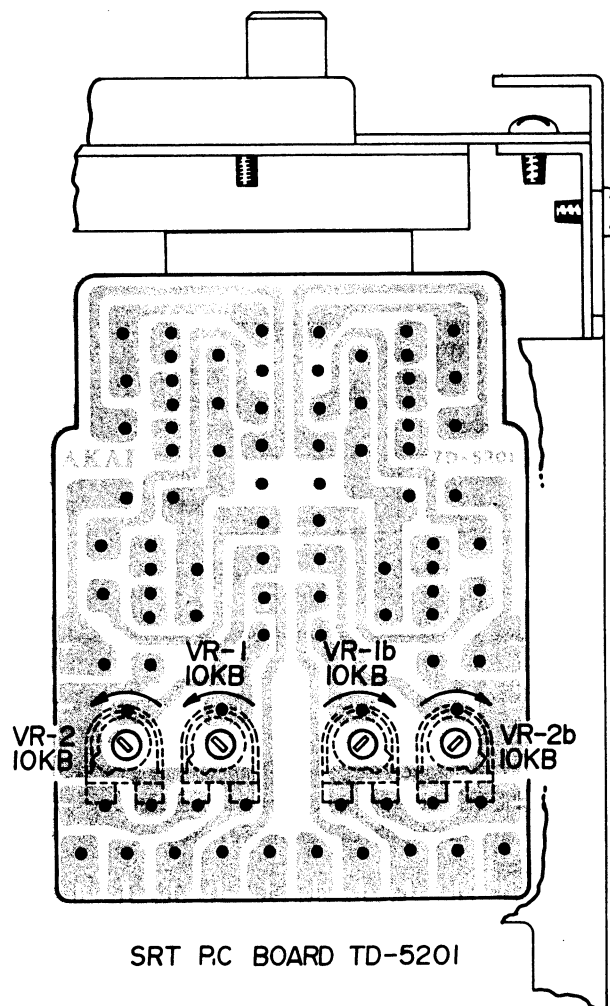

Fig. 14

Step	Adjustment Item	Test Tape Supply Signal	Mode	Adjustment Point	Result	Remarks
1	Playback Level Adjustment	700 Hz 7-1/2 ips 0 VU Test Tape	PLAY	VR-1 50 kB	0 ± 1.5 dB (0.775V)	
2	VU Meter Sensitivity Adjustment	700 Hz 7-1/2 ips 0 VU Test Tape	PLAY	VR-3 2 kB	0 VU	
3	Recording Level Adjustment	SCOTCH #211 Tape 1,000 Hz 0 VU recording	REC	VR-2 10 kB	0 ± 1.5 dB (0.775V)	
4	Frequency Response Adjustment	SCOTCH #211 Tape 1,000 Hz 10,000 Hz -20 VU recording	REC	C-25 80P	1,000 Hz to 10,000 Hz flat	Tape Speed 3-3/4 ips. Recheck recording level.
5	Bias Leak		REC	L-1 23 mH	Less than -30 VU	Less than -20 VU at monaural.

Chart 2

4. RECORDING AND PLAYBACK AMPLIFIER ADJUSTMENT (Model GX-630DB) (Refer to Figs. 13, 14)

Step	Adjustment Item	Test Tape Supply Signal	Mode	Adjustment Point	Result	Remarks
1	Playback Level Adjustment	700 Hz 7-1/2 ips 0 VU Test Tape	PLAY	VR-1 50 kB	0 ± 1.0 dB (0.775V)	
2	VU Meter Sensitivity Adjustment	700 Hz 7-1/2 ips 0 VU Test Tape	PLAY	VR-3 2 kB	0 VU	
3	Recording Level Adjustment (Low Noise Tape)	SCOTCH #211 Tape 1,000 Hz 0 VU recording	REC	VR-1 10 kB	0 ± 1.5 dB (0.775V)	
4	Recording Level Adjustment (Wide Range Tape)	AKAI LN-150-7 Tape 1,000 Hz 0 VU recording	REC	VR-2 10 kB	0 ± 1.5 dB (0.775V)	
5	Frequency Response Adjustment	SCOTCH #211 Tape 1,000 Hz 10,000 Hz -20 VU recording	REC	C-25 80P	1,000 Hz to 10,000 Hz flat	Tape Speed 3-3/4 ips. Recheck recording level.
6	Bias Leak		REC	L-1 23 mH	Less than -50 VU	
7	Dolby Noise Reduction Adjustment					Refer to Item V-5 below.

Chart 3

- NOTES: 1) Set tape speed to 3-3/4 ips for frequency response adjustment and to 7-1/2 ips for all other adjustments.
2) Set Tape Selector to "LOW NOISE" except where otherwise noted.
3) Set Monitor Switch to "TAPE" except where otherwise noted.
4) Output Volume at maximum.
5) New test tape should be used.
6) The letter b following an adjustment part number indicated "Right Channel".

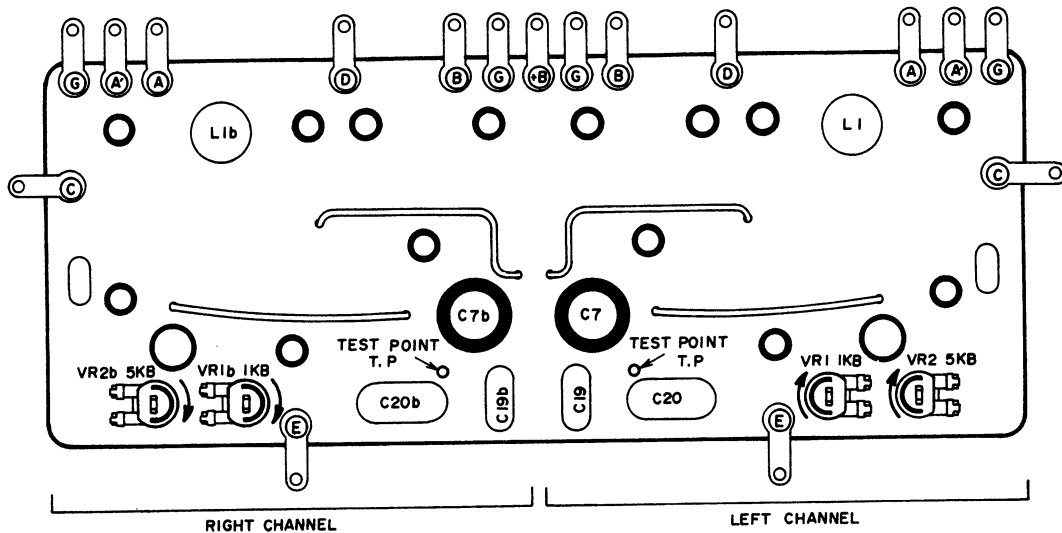

DOLBY NR P.C BOARD TD-5301

Fig. 15

5. DOLBY NOISE REDUCTION ADJUSTMENT (Model GX-630DB) (Refer to Fig. 15)

NOTE: Identical P.C Boards are utilized for Recording Dolby N.R and Playback Dolby N.R. The Recording Dolby N.R P.C Board is located on the Recording Amp P.C Board and the Playback Dolby N.R P.C Board is located on the Playback Amp P.C Board, Adjust left and right channels respectively.

PART-1. RECORDING DOLBY N.R CIRCUIT ADJUSTMENT

Disconnect the wire connected to Dolby circuit input and output terminals (A) and (B). Connect an Audio frequency oscillator to terminal (A) and connect a High-sensitivity VTVM to terminal (B).

- 1) Turn semi-fixed resistors VR1 1k Ω and VR2 5 k Ω fully clockwise (Fig. 15).
- 2) Ground test points T.P (Fig. 15)
- 3) Set Dolby Switch to OFF position.
- 4) Supply a 5 kHz, -10 dBm signal which has been verified with a frequency counter from the audio frequency oscillator and confirm that at this time the indication of the high-sensitivity VTVM connected to terminal (B) is 0 dBm.
- 5) Reduce the output of the audio frequency oscillator by -30.5 dB from the condition outlined in item 1-4) (5 kHz, -40.5 dB) and at this time confirm that the indication of the high-sensitivity VTVM connected to terminal (B) is -30.5 dB.
- 6) Set Dolby Switch to ON position and adjust semi-fixed resistor VR1 1 k Ω to obtain a -20.5 dBm indication on the high-sensitivity VTVM connected terminal (B).
- 7) Disconnect ground wire from test point T.P (grounded in item 1-2) and at this time adjust semi-fixed resistor VR2 5 k Ω to obtain a -22.5 dBm indication on the high-sensitivity VTVM connected to terminal (B).

PART-2. PLAYBACK DOLBY N.R CIRCUIT ADJUSTMENT

This adjustment is carried out in essentially the same way as the recording Dolby circuit adjustment.

Disconnect the wire connected to input and output terminals(A') and (B), connect an audio frequency oscillator to terminal(A'), and connect a high-sensitivity VTVM to terminal(B). Turn semi-fixed resistor VR1 1 k Ω and VR2 5 k Ω fully clockwise, and ground test points T.P.

- 1) Set Dolby Switch to OFF position and supply a 5 kHz, 10 dBm signal which has been verified with a frequency counter from the audio frequency oscillator, Confirm that the high-sensitivity VTVM indication at this time is 0 dBm. Next, lower the oscillator output by -22.5 dB and confirm that the high-sensitivity VTVM indication is -22.5 dB.
- 2) Set Dolby Switch to ON position and at this time adjust semi-fixed resistor VR1 1 k Ω to obtain a -32.5 dB high-sensitivity VTVM indication. Next, disconnect ground wire from test points T.P and adjust semi-fixed resistor VR-2 5 k Ω to obtain a -30.5 dBm indication.

VII D.C RESISTANCE OF VARIOUS COILS

Part	Designation	D.C Resistance
Main Motor	SCM2-24KJ	Between BLU-RED: 100 ohm Between YLW-GRN: 180 ohm Pick-up Coil: 635 ohm
Reel Motor	24XO-TD	Between RED-BLU: 72 ohm Between YLW-GRN: 160 ohm
Pinch Roller Solenoid	1660 THT3	700 ohm
Brake Solenoid	1240 PHT3	900 ohm
Relay	MY4-02-US-24DC	700 ohm
Relay	LC1-C-J1DC-24V	1,150 ohm
Relay	TECK-36	1,000 ohm
Headphone Output Transformer	N16-535S	Primary: 565 ohm \pm 15% Secondary: 0.95 ohm \pm 15%
Oscillator Coil	OT-204	Between 1 - 3 : 0.3 ohm Between 4 - 6 : 0.7 ohm Between 7 - 9 : 8.2 ohm
Erase Head	E4-260	2.0 ohm
Recording Head	R4-200	8.0 ohm
Playback Head	P4-202	268 ohm

Chart 4

NOTE: The resistance values shown in this chart are average values.

2) RELAY P.C BOARD TE-2002

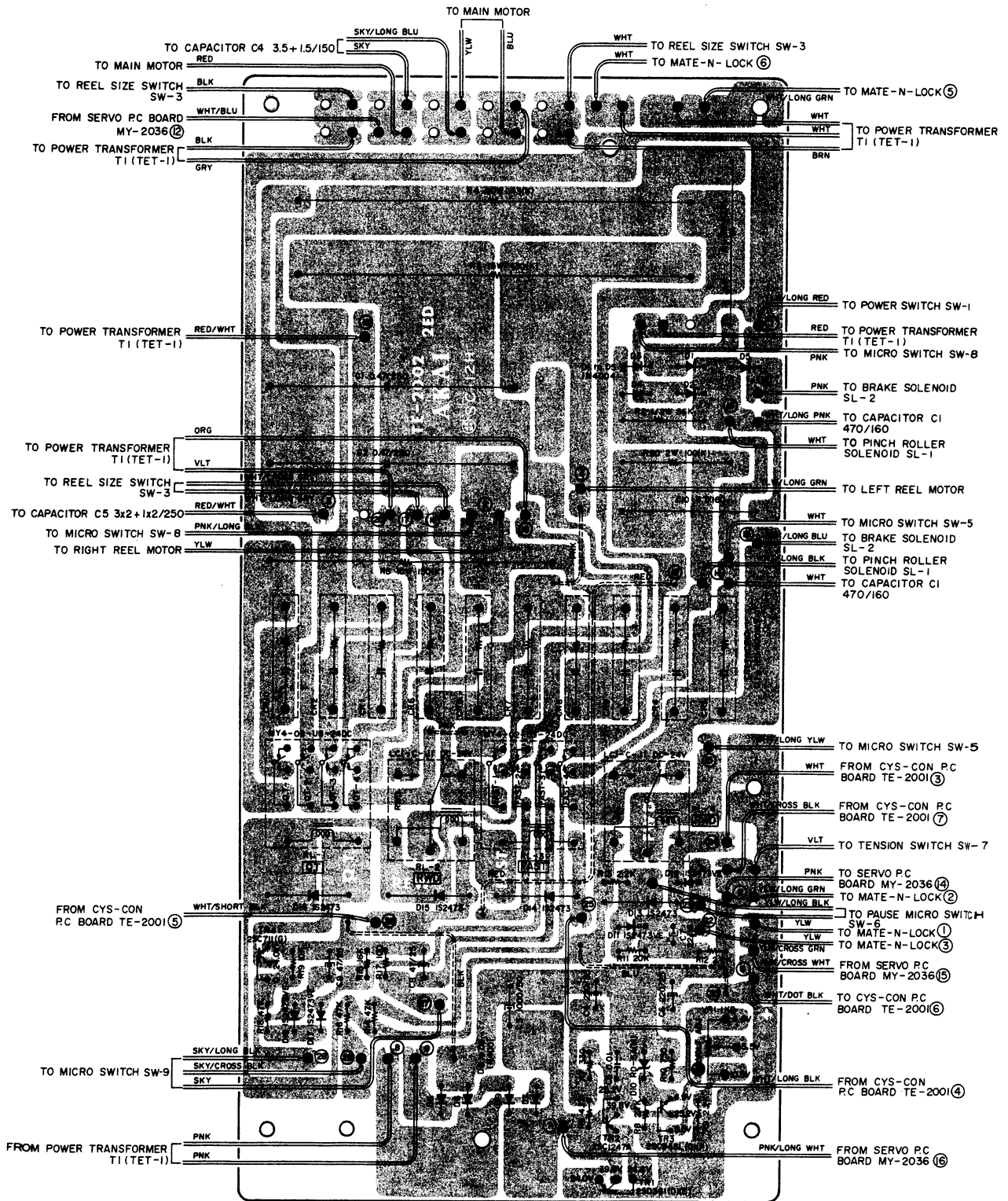

3) SERVO P.C BOARD MY-2036

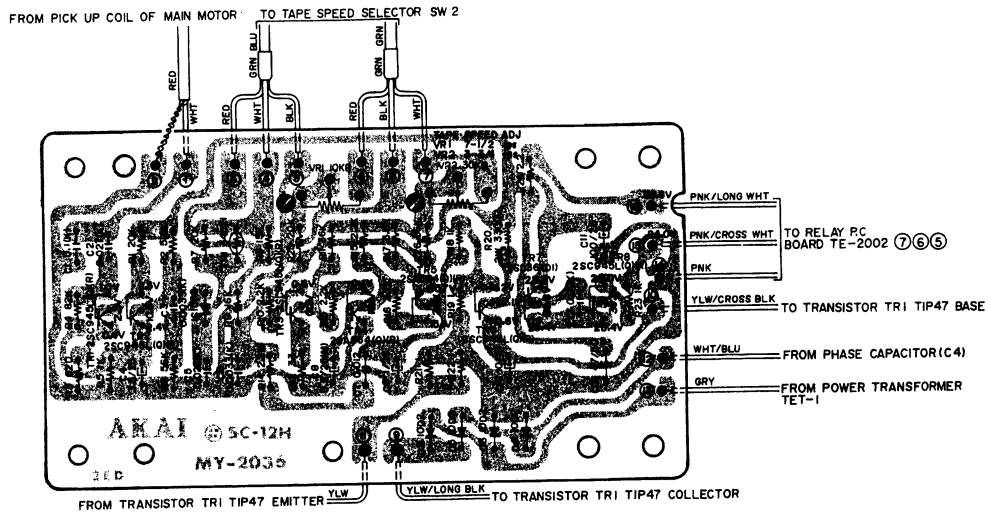

4) RECORDING AMP P.C BOARD MY-5016

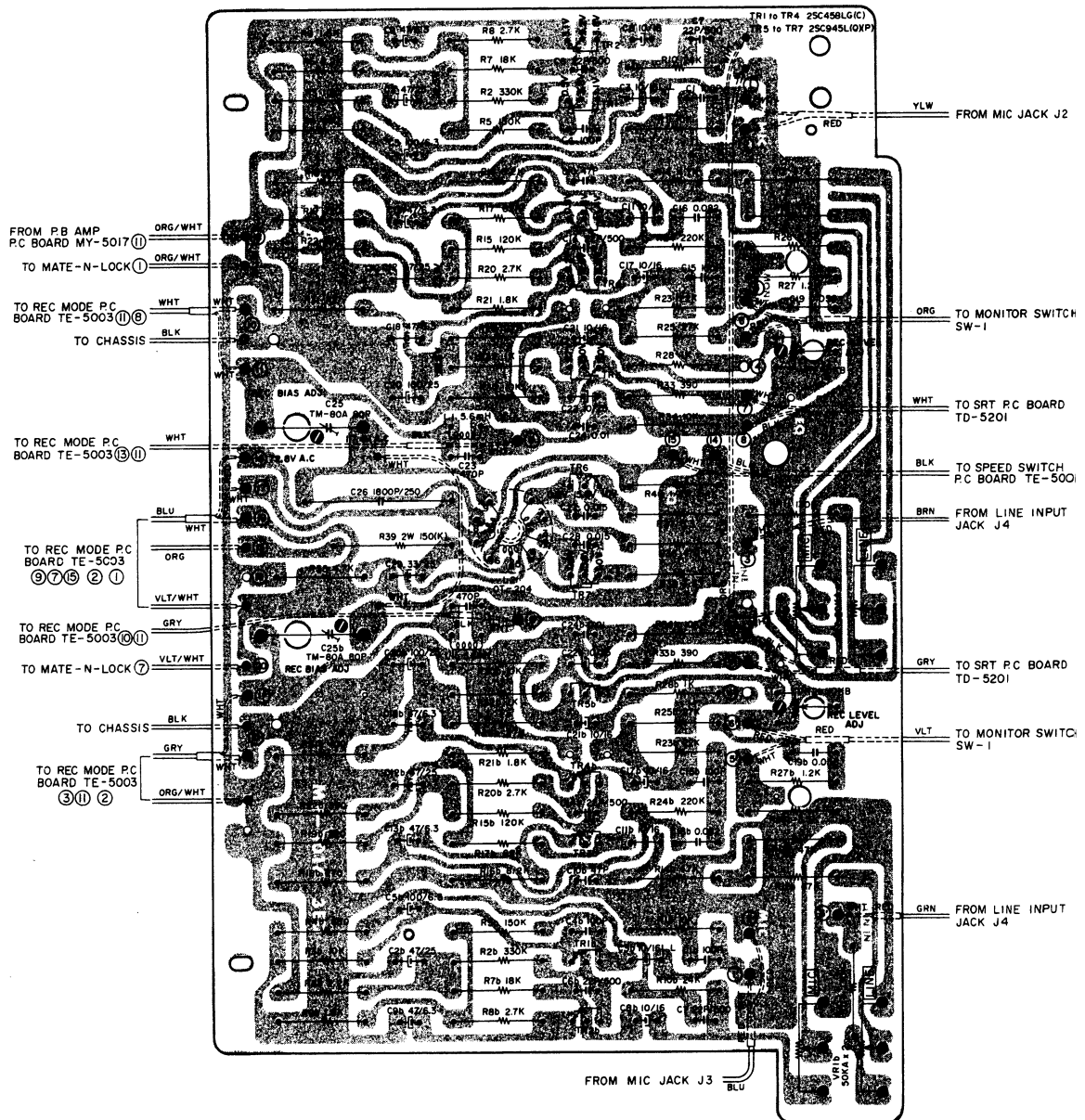

5) PLAYBACK AMP P.C BOARD MY-5017

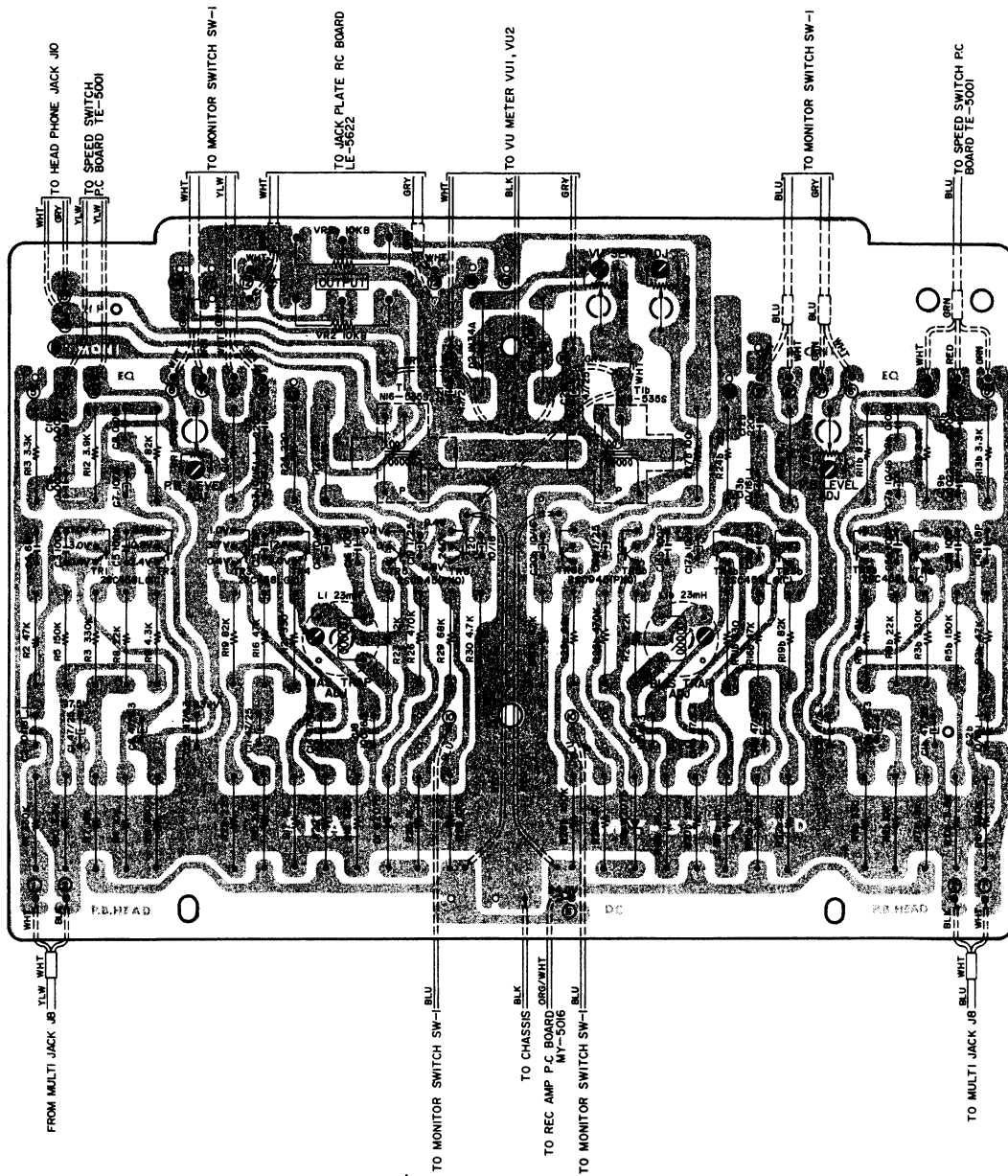

6) RECORDING MODE P.C BOARD TE-5003

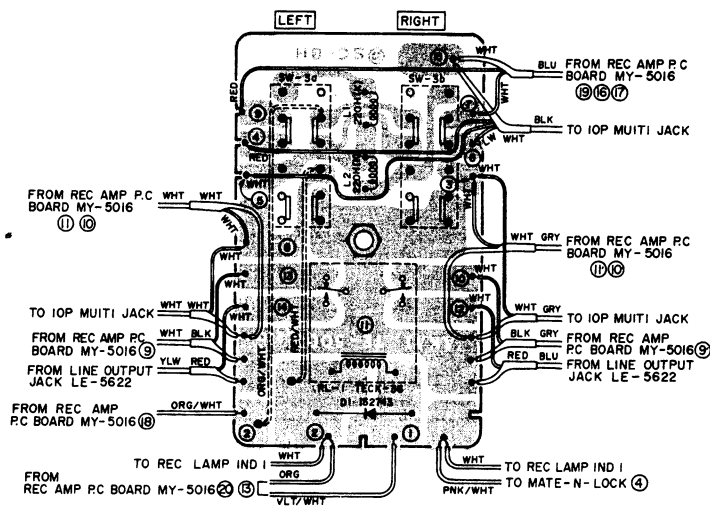

7) SRT P.C BOARD TD-5201

A. GX-630D

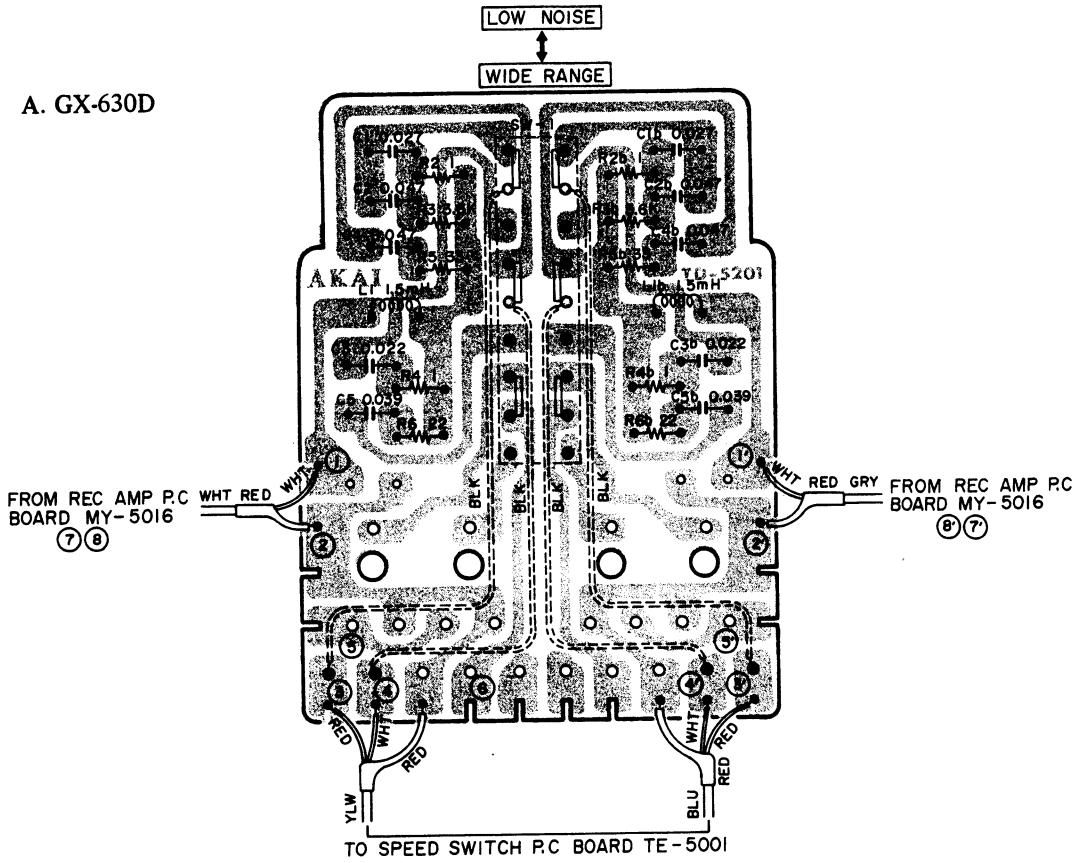

B. GX-630DB

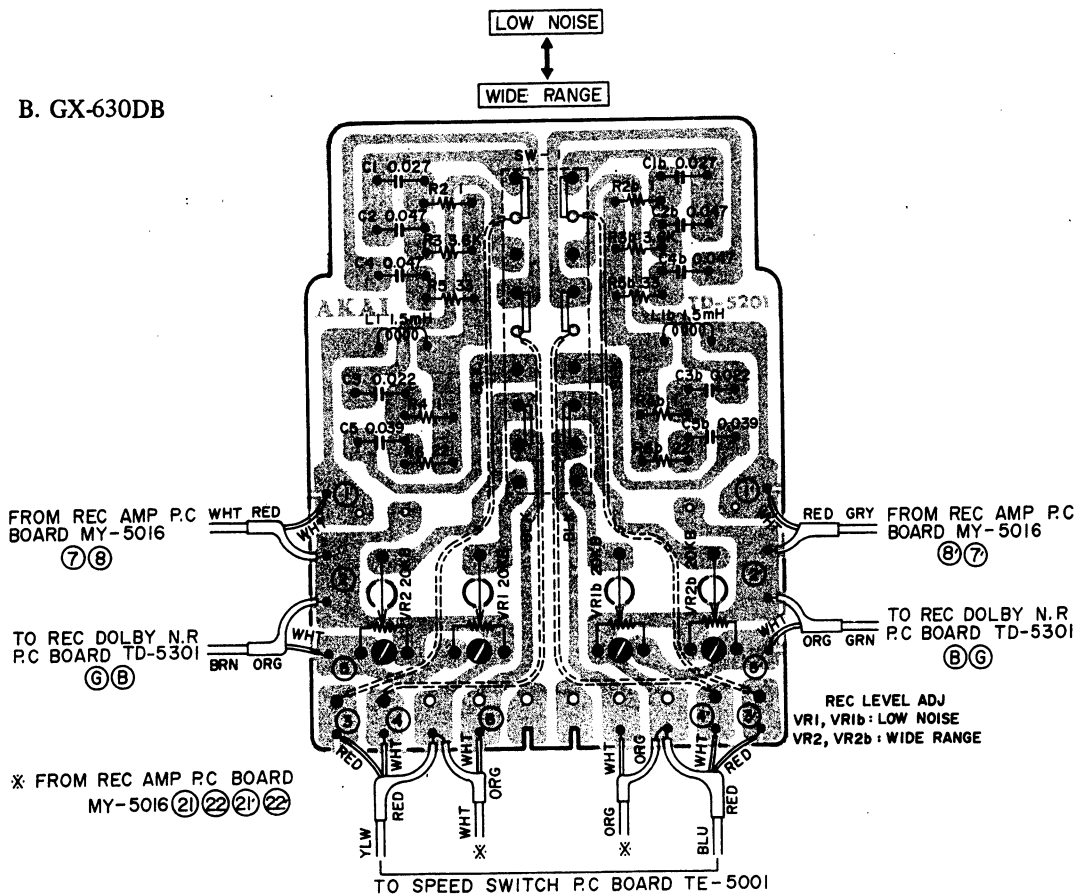

8) JACK PLATE P.C BOARD LE-5622

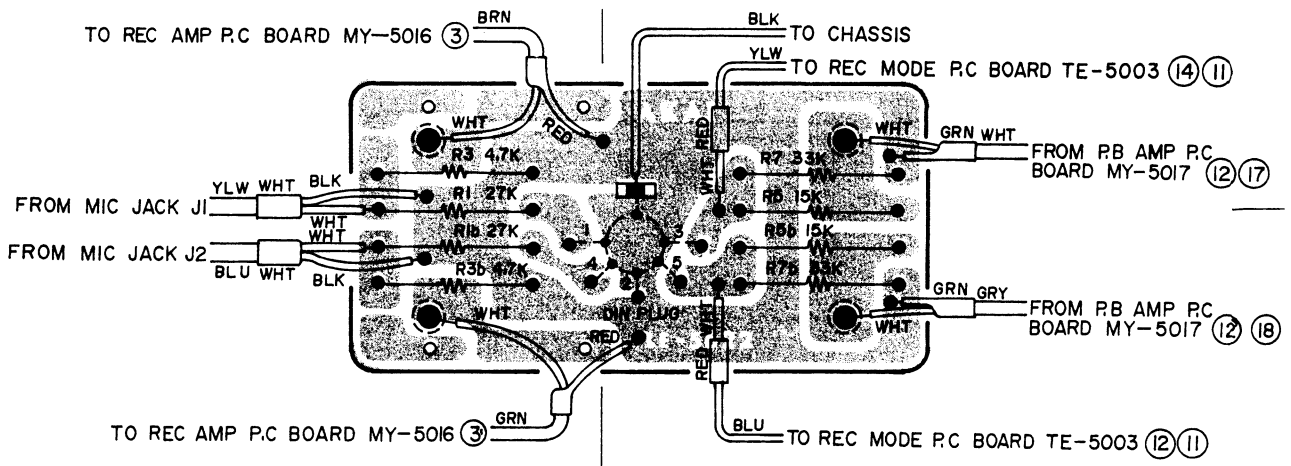

9) TRANSISTOR P.C BOARD KJ-2049

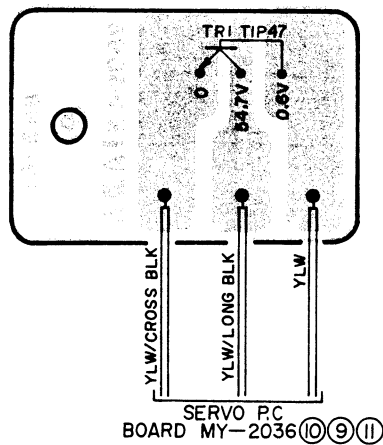

10) SPEED SWITCH P.C BOARD TE-5001

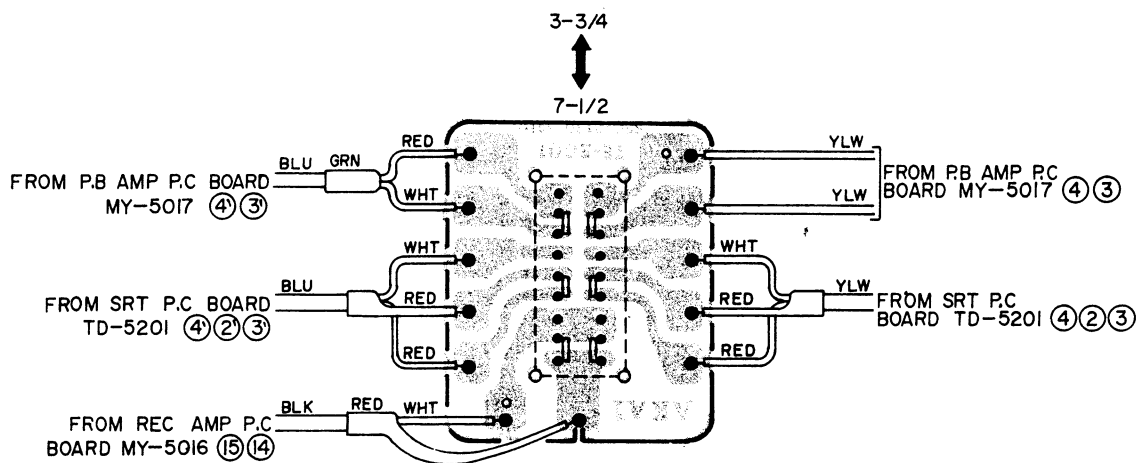

SECTION 2

PARTS LIST

TABLE OF CONTENTS

1. HEAD BLOCK	26
2. MAIN MOTOR BLOCK	28
3. REEL MOTOR/REEL TABLE BLOCK	29
4. IMPEDANCE ROLLER BLOCK	30
5. BRAKE PLUNGER BLOCK	31
6. TENSION ARM BLOCK	32
7. POWER SUPPLY/CONNECTOR PANEL BLOCK	34
8. MECH. ASSEMBLY BLOCK	35
9. P.B P.C BOARD (MY-5017) BLOCK	37
10. REC, OSC P.C BOARD (MY-5016) BLOCK	37
11. DOLBY P.C BOARD (TD-5301) BLOCK	37
12. SRT P.C BOARD (TD-5201) BLOCK	38
13. SYS. CON P.C BOARD (TE-2001) BLOCK	38
14. SERVO P.C BOARD (MY-2036) BLOCK	38
15. RELAY P.C BOARD (TE-2002) BLOCK	38
16. REC MODE P.C BOARD (TE-5003) BLOCK	39
17. SPEED SWITCH P.C BOARD (TE-5001) BLOCK	39
18. AMP. ASSEMBLY BLOCK	40
19. FINAL ASSEMBLY BLOCK	41
20. LIST OF INTERCHANGEABLE SEMICONDUCTORS	42
INDEX	43

Some of the parts in this parts list are only available as a complete assembly, and can not be supplied as individual parts.

i ILLUSTRATION OF HEAD BLOCK

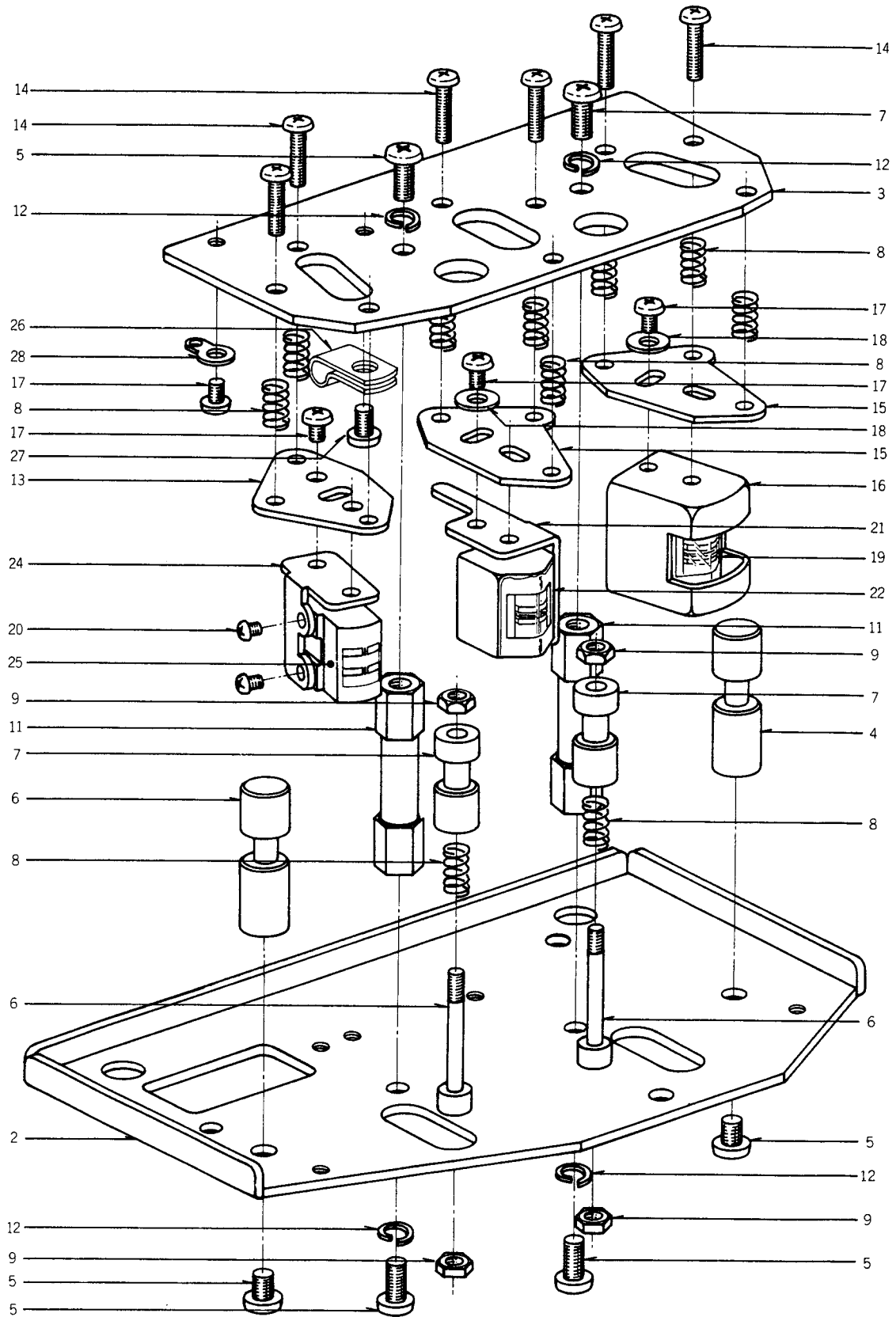

When ordering parts, please describe Parts Number, Serial Number, and Model Number in detail.

1) HEAD BLOCK

Ref. No.	Parts No.	Description	Schematic No.	Q'ty
1-1x	BH638008	Head Block Comp. GX-630D/DB		1
1-2	HZ643544	Head Base	TE-0001	1
1-3	HZ645298	Head Base C	TD-0001	1
1-4	HZ803597	Tape Guide A	RD-3	2
1-5	ZS537006	Screw, binding head 4x8		6
1-6	MH578957	Tape Guide Prop	TD-0003	2
1-7	HZ532710	Tape Guide B	TW-0006	2
1-8	ZG466312	Angle Adjust Spring E	BS-0018	11
1-9	ZW273835	Nut M3		4
1-10x	ZW273745	Spring Washer M3		2
1-11	MH529233	Head Base Prop B	ND-0017	2
1-12	ZW273914	Spring Washer M4		4
1-13	HZ532732	CH Retaining Base	TW-0008	1
1-14	ZS562432	Screw, binding head 3x13		9
1-15	HZ532765	PH Retaining Base	TW-0010	2
1-16	HZ532776	Shield Case	TW-0011	1
1-17	ZS396000	Screw, binding head 3x4		7
1-18	ZW413256	Washer (SPC) D3.4x7.8x0.5t		2
1-19	HP536501	PB. HEAD P4-202		1
1-20	ZS394525	Screw, binding head 2x3		2
1-21	HA533597	RH Angle	TW-0201	1
1-22	HR384513	REC. HEAD R4-200		1
1-23x	ZS460438	Screw, binding head 2x3		2
1-24	HA533608	EH Angle	TW-0202	1
1-25	HE563220	ERASE HEAD E4-260		1
1-26	EJ315101	Nylon Clip HP-4N	2-7-38	1
1-27	ZS355511	Screw, binding head 3x6		1
1-28	ZW273881	Earth Lug M4		1

2) MAIN MOTOR BLOCK

Ref. No.	Parts No.	Description	Schematic No.	Q'ty
2-1x	BM637975	Main Motor Block (SCM2-24KJ) Comp.		KJ,MY,NE,TE 1
2-2	ZW597543	Thrust Washer A		KJ-7009 2
2-3	ZW597622	Felt Washer		KJ-7022 1
2-4	SK597633	Cap		KJ-7023 1
2-5	BZ600300	Detector Gear Block Comp.		KJ,MY,NE,TE 1
2-6	MV368886	Steel Ball D3		1
2-7	MZ650046	Motor Shield Plate		TE-7008 1
2-8	MZ597644	Thrust Angle		KJ-7024 1
2-9	MZ597690	Ball Holder		KJ-7029 1
2-10	MS597655	Thrust Holding Prop		KJ-7025 2
2-11	ZS413234	Screw, pan head 4x12		4
2-12	ZW603786	Adjust, Washer (U) D4x13x0.2t		2
2-13x	ZW603797	Adjust, Washer (U) D4x13x0.5t		2
2-14x	ZW603764	Adjust, Washer (U) D4x13x1.2t		2
2-15x	ZW603775	Adjust, Washer (U) D4x13x1.6t		2
2-16	EZ627862	Coil End Shield Plate		MY-7001 1

2 ILLUSTRATION OF MAIN MOTOR BLOCK

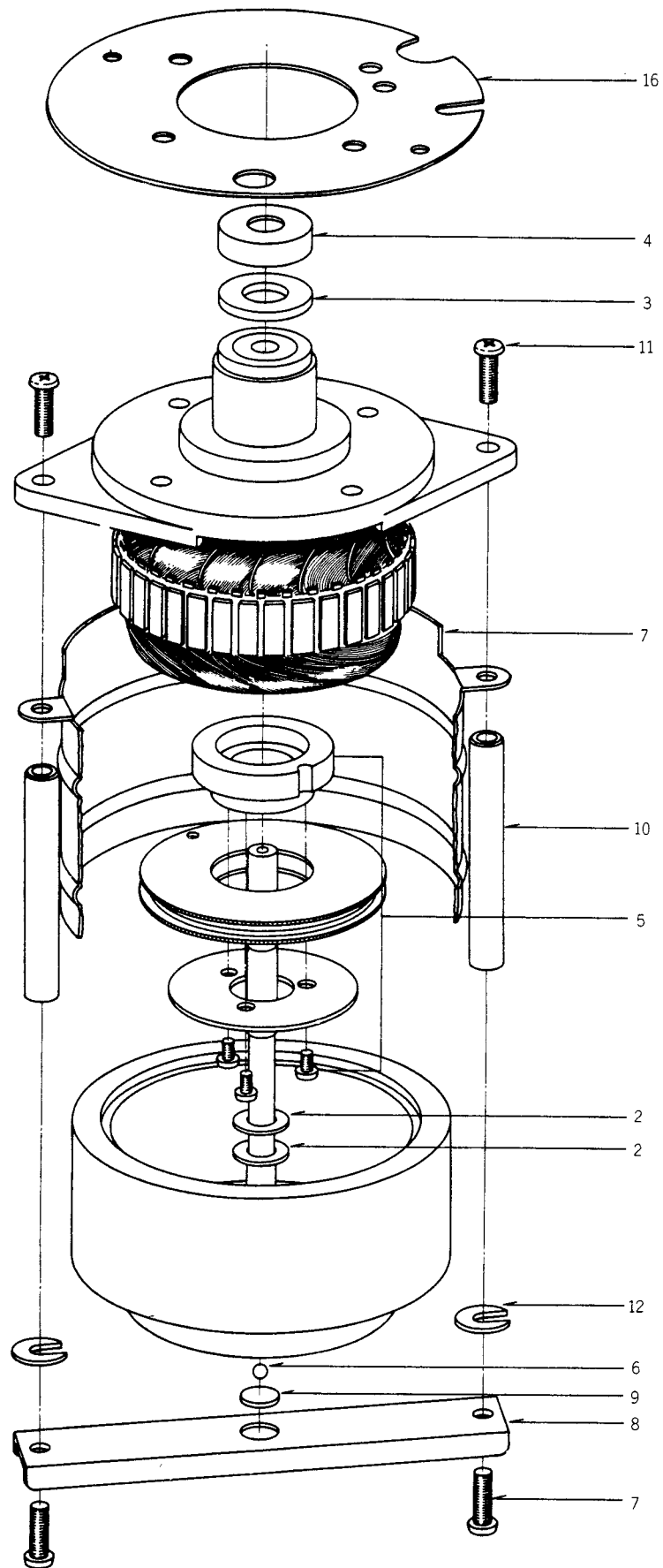

3 ILLUSTRATION OF REEL MOTOR/REEL TABLE BLOCK

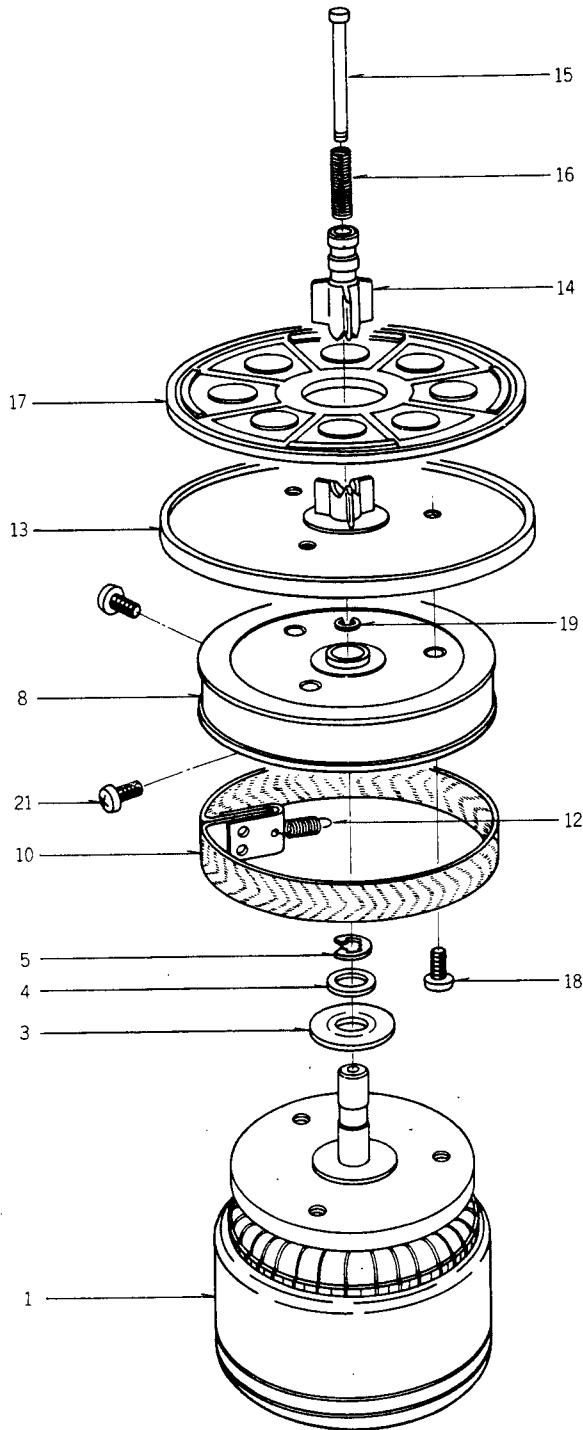

3) REEL MOTOR/REEL TABLE BLOCK

Ref. No.	Parts No.	Description	Schematic No.	Q'ty
REEL MOTOR BLOCK				
3-1	BM587518	Reel Motor Block (24XO-TD)		1
		Comp.	TD,TE,TY	1
3-2x	MV408510	Bearing 608VVMC2ERAV2L		1
3-3	MZ248185	Bearing Retainer	3R-758	1
3-4	ZW260278	Washer (Nylon) D8.1x13x0.5t		1
3-5	ZW270156	'E' Ring 6M	6-1-9	1
REEL TABLE BLOCK				
3-6x	BR587542	Reel Table Block (Left)	TD,TE	1
3-7x	BR587553	Reel Table Block (Right)	TD,TE	1
3-8	MT577473	Brake Drum Left B	MR-216	1
3-9x	MZ576538	Brake Drum Light B	MR-216	1
3-10	MT436860	Brake Cloth Comp.	MR-269	1
3-11x	MT317485	U Metal Fitting	MR-218	1
3-12	ZG317496	Felt Tension Spring	MR-260	1
3-13	MT534666	Reel Table	TW-2131	1
3-14	MT534677	Reel Clamper	TW-2132	1
3-15	MS342000	Reel Shaft	3R-101	1
3-16	ZG540617	Clamp Spring	TW-2196	1
3-17	MT534688	Reel Table Rubber	TW-2133	1
3-18	ZS413785	Screw, binding head 3x12		3
3-19	ZW270088	'E' Ring 1.9M	6-1-9	1
3-20x	ZW562476	Earth Lug M3		1
3-21	ZS435273	Screw, binding Head 4x10		2

4 ILLUSTRATION OF IMPEDANCE ROLLER BLOCK

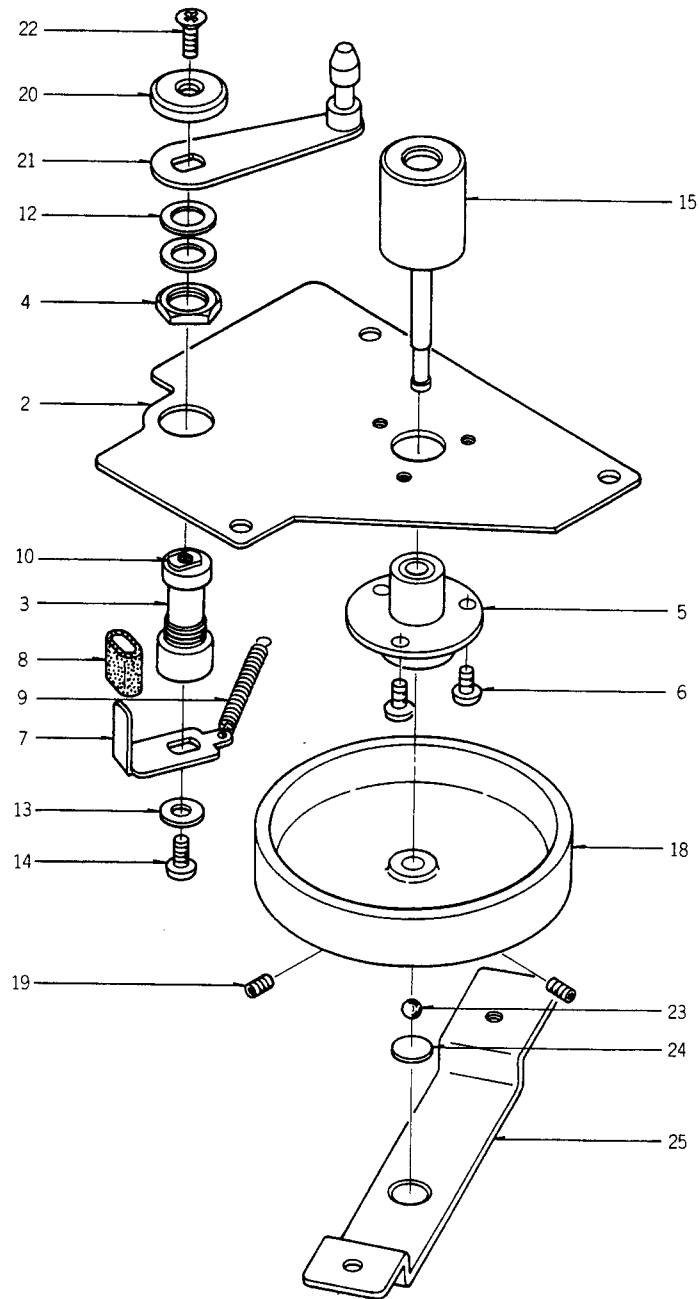

4) IMPEDANCE ROLLER BLOCK

Ref. No.	Parts No.	Description	Schematic No.	Q'ty	Ref. No.	Parts No.	Description	Schematic No.	Q'ty
4-1x	BI637931	Impedance Roller Block	TE	1	4-15	MR597115	Impedance Roller, w/shaft	KJ-2033	1
		Comp.	TE-2004	1	4-16x	MZ597126	Roller Plate	KJ-2035	1
4-2	MZ643375	Impedance Plate	TE-2005	1	4-17x	ZW655953	Washer D4.1x10x1t		1
4-3	MV643386	Shaft Metal	6-3-9	1	4-18	MI597183	Flywheel	KJ-2041	1
4-4	ZW603990	Metal Nut		1	4-19	ZS593796	Set Screw, hexagon socket 3x6 (Flat/P.)		2
4-5	MZ597093	Metal Case, w/metal	KJ-2029	1	4-20	ZW535094	Decorative Washer	TW-2077	1
4-6	ZS499331	Screw, pan head 2.3x5		3	4-21	MZ643858	T Arm, w/Guide	TE-2003	1
4-7	MZ643408	Stopper	TE-2007	1	4-22	ZS411660	Screw, oval countersunk head 3x6		2
4-8	MB665561	TE Stopper Rubber	TE-2039	1	4-23	MV269965	Steel Ball D4		1
4-9	ZG535105	Tension Arm Spring	TW-2078	1	4-24	ZW235585	Nylon Plate D8		1
4-10	MS643397	Shaft	TE-2006	1	4-25	MZ640664	Thrust Supporting Plate	TE-2022	1
4-11x	ZS481724	ISO Screw, truss head 3x6		1					
4-12	ZW260010	Washer (PBP) D6.1x10x0.1t		3					
4-13	ZW556828	Washer D3.5x10x0.5t		1					
4-14	ZS417216	Screw, pan head 3x4		1					

5 ILLUSTRATION OF BRAKE PLUNGER BLOCK

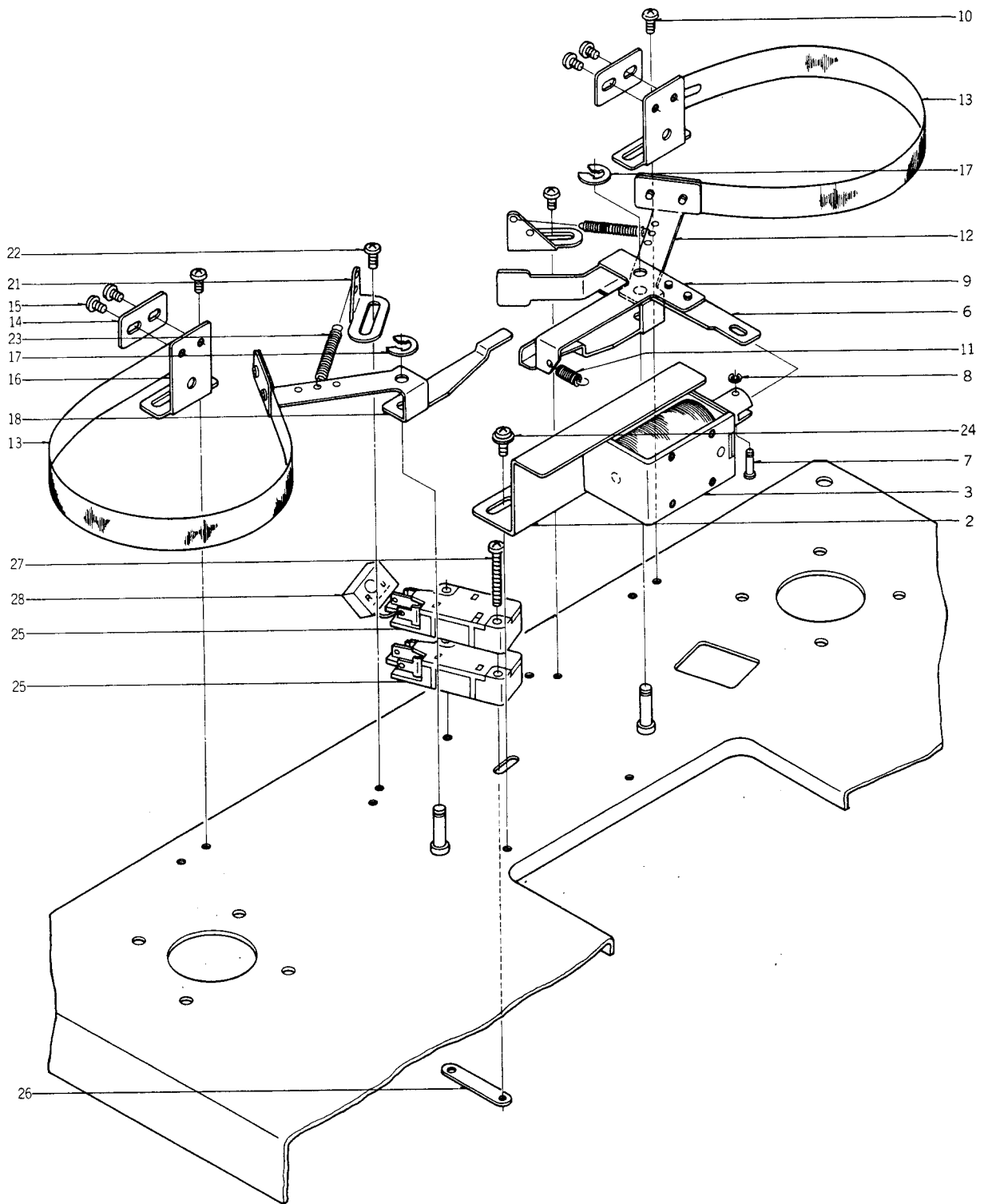

6 ILLUSTRATION OF TENSION ARM BLOCK

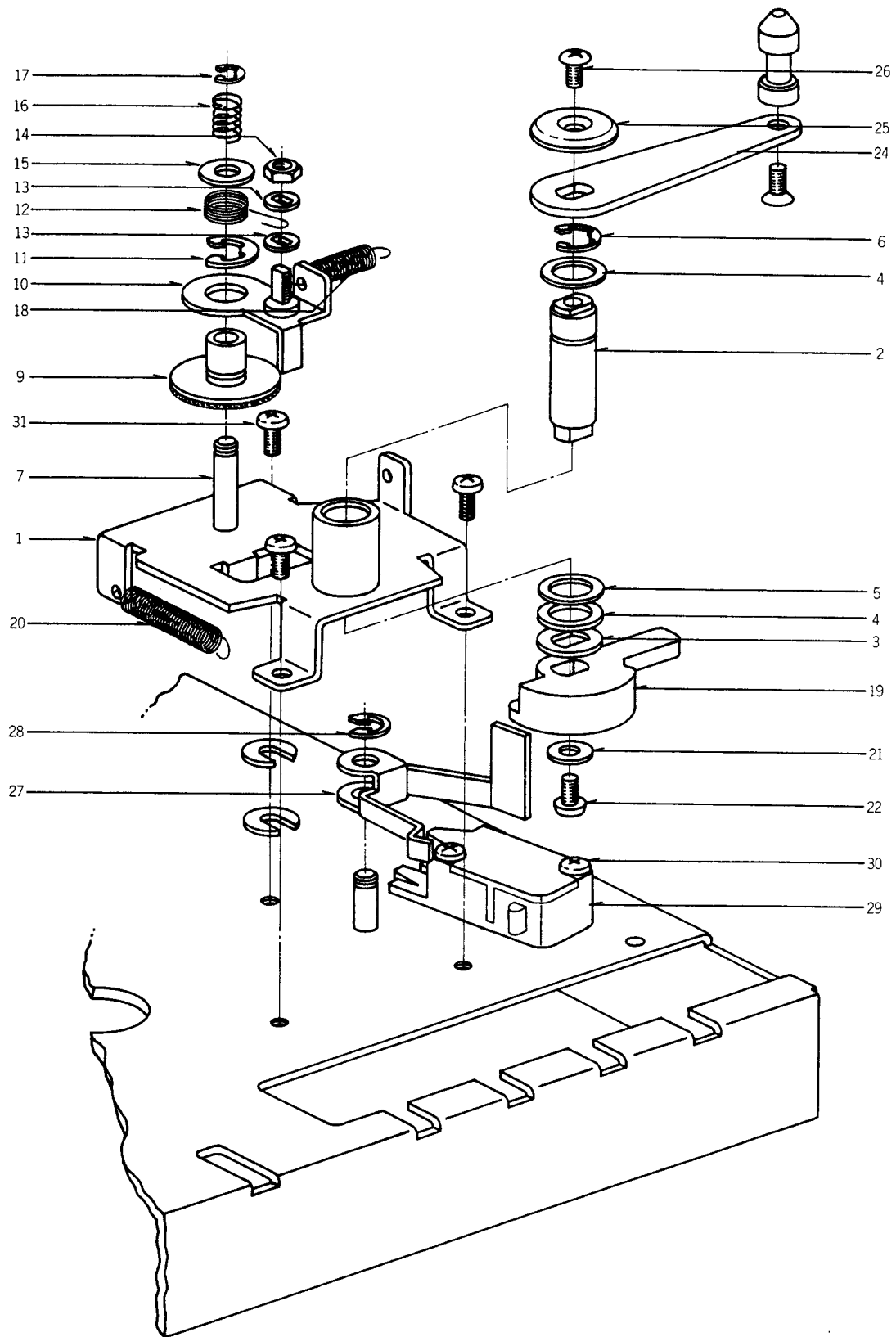

5) BRAKE PLUNGER BLOCK

Ref. No.	Parts No.	Description	Schematic No.	Q'ty
5-1x	BZ637986	Brake Plunger Block Comp.	TE	1
5-2	MZ643498	Plunger Retaining Plate	TE-2016	1
5-3	EP638695	Plunger Solenoid 1240PHT3	44-1-80	1
5-4x	ED570273	Silicon Diode LN4004	45-2-59	1
5-5x	ZS422076	Screw, pan head 3x5		2
5-6	ML643476	Brake Plunger Lever	TE-2014	1
5-7	MH257477	Connecting Pin	RD-211	1
5-8	ZW270088	'E' Ring 1.9M	6-1-9	1
5-9	ML643387	Brake Band Lever	TE-2015	1
5-10	ZS323728	Screw, binding head 3x5		6
5-11	ZG586427	Reverse Spring	CP-1192	1
5-12	ML533643	Brake Lever B	TW-1030	1
5-13	MT314987	Brake Band	MR-213	2
5-14	MZ314998	Brake Band Retaining Plate	MR-212	4
5-15	ZS417137	Screw, binding head 3x4		8
5-16	ML582074	Brake Band Support	TD-1023	2
5-17	ZW290283	'U' Ring 2.85M	6-1-1	2
5-18	ML582041	Brake Lever A	TD-1019	1
5-19x	MZ317406	Brake Band Guide	MR-120	2
5-20x	ZS413166	Screw, round head 3x6		4
5-21	MZ314605	Spring Rack, MR	MR-104	2
5-22	ZS379405	ISO Screw, binding head 3x6		4
5-23	ZG540090	Brake Lever Spring	TW-1058	2
5-24	ZS422076	Screw, pan head 3x5		2
5-25	ES573456	Micro SW. K-2	25-1-30	2
5-26	ZW397146	Micro SW. Nut	KD-1057	1
5-27	ZS608354	Scres, pan head 3x30		2
5-28	ER450786	Spark Quencher U/L 0.1μ+120ohm 400WV	41-1-33	1

6) TENSION ARM BLOCK

Ref. No.	Parts No.	Description	Schematic No.	Q'ty
6-1	ML580443	Tension Arm Base, w/metal	TD-2037	1
6-2	MS645502	Tension Shaft	TD-2041	1
6-3	ZW580498	Tension Arm Washer	TD-2042	1
6-4	ZW575763	Washer (SPC) D8.1x13x0.5t		2
6-5	ZW260256	Washer (PBP) D8.1x13x0.1t		2
6-6	MH244710	Flywheel Fixing Pin	900-250	1
6-7	MH580588	Damper Prop	TD-2052	1
6-8x	TC387617	Clutch Felt	CS-2011	1
6-9	MZ580577	Clutch Plate, w/metal A	TD-2051	1
6-10	ML580555	Clutch Lever, w/spring retainer	TD-2048	1
6-11	ZW270156	'E' Ring 6M	6-1-9	1
6-12	ZG580511	Clutch Spring	TD-2044	1
6-13	ZW580678	Spring Retaining Washer	TD-2067	2
6-14	ZW273756	Nut M3		2
6-15	ZW575774	Washer D4.5x9.8x0.7t		1
6-16	ZG580533	Cramp Spring	TD-2046	1
6-17	ZW410051	'E' Ring 2.5	6-1-9	1
6-18	ZG580522	Clutch Lever Spring	TD-2045	1
6-19	MZ580500	Cam. SW.	TD-2043	1
6-20	ZG659608	Tension Spring	TE-2034	1
6-21	ZW550642	Washer (SPC) D3.1x7.9x0.5t		1
6-22	ZS323728	Screw, binding head 3x5		1
6-23x	MZ810191	Cushion Rubber, RD	RD-278	1
6-24	ML580465	Tension Arm, w/guide B	TD-2039	1
6-25	ZW535094	Decorative Washer	TW-2077	1
6-26	ZS200384	Screw, countersunk head 3x6		1
6-27	MZ580680	Actuator	TD-2068	1
6-28	ZW290283	'U' Ring 2.85M	6-1-1	1
6-29	ES573456	Micro SW. K-2	25-1-30	2
6-30	ZS508354	Screw, pan head 3x30		2
6-31	ZS413155	Screw, binding head 3x6		4

7 PHOTO OF POWER SUPPLY/CONNECTOR PANEL BLOCK

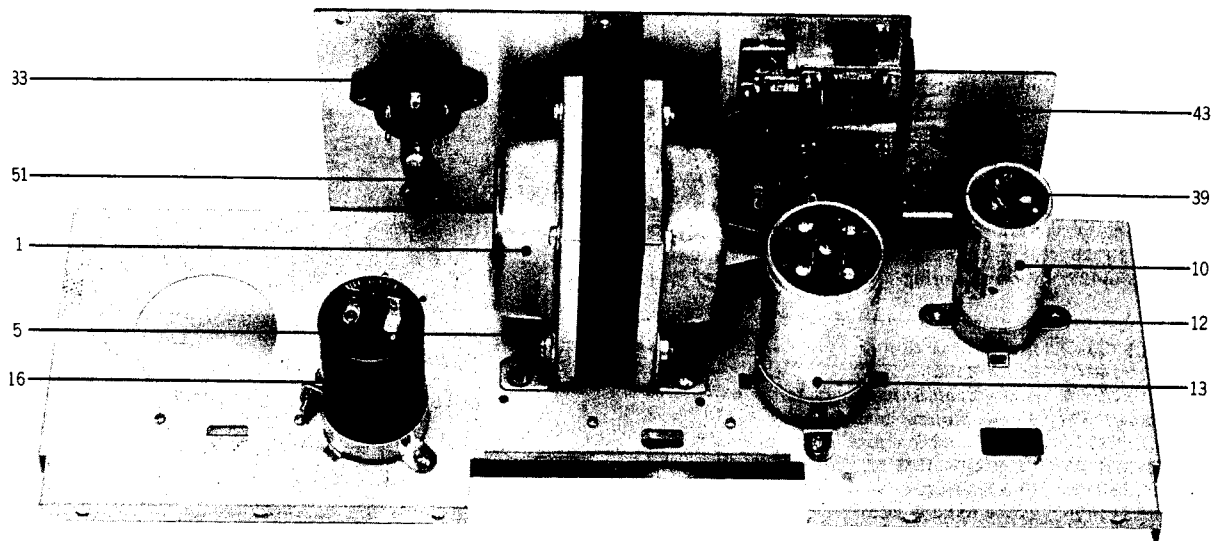

7) POWER SUPPLY/CONNECTOR PANEL BLOCK

Ref. No.	Parts No.	Description	Schematic No.	Q'ty	Ref. No.	Parts No.	Description	Schematic No.	Q'ty
POWER SUPPLY BLOCK									
7-1	BT640517	Power Trans. TET-1	38-4-354	1	7-26x	EJ654221	Lug Plate KPL4L (CEE,CSA,JPN)	33-3-26	1
7-2x	BT661858	Power Trans. TET-5 (CEE)	38-4-389	1	7-27x	ZW273881	Earth Lug M4 (CEE)		1
7-3x	BT661926	Power Trans. TET-4 (CSA)	38-4-388	1	7-28x	ZS417150	Screw, pan head 4x6 (CEE)		1
7-4x	BT661904	Power Trans. TET-3 (JPN)	38-4-387	1	7-29x	ZW413188	Nut M4 (CEE)		1
7-5	ZW510827	Tapping Screw #2 4x6 BR		4	7-30x	ZW273892	Toothed Lock Washer M4 (CEE)		1
7-6x	ZS413201	Screw, pan head 4x8 (CEE, CSA, JPN)		4	7-31x	MT553948	Wire Band B	2-35-3	2
7-7x	ZW273892	Toothed Lock Washer M4 (CEE)		4	7-32x	EJ510333	Wire Clip 220-JD481610-0104 (Nylon)	2-7-17	1
7-8x	ZW413188	Nut M4 (CEE, CSA, JPN)		4	7-33	EJ233370	Socket (Volt. Selector) S-18010	40-2-3	1
7-9x	ZW273914	Spring Washer M4 (CSA, JPN)		4	7-34x	EZ654208	Fuse Holder TE (CEE,JPN)	40-1-74	1
7-10	EC593763	MP/C. 3.5+1.5μF 150WV AC (LUG Type Uni/D.)	24-9-88	1	7-35x	EZ655198	Fuse Holder 5P Base (CSA)	40-1-71	1
7-11x	EC661882	MP/C. 5μF 150WV AC (Lug Type Uni/D.) (CEE)	24-9-111	1	7-36x	MZ583198	Fuse Angle TD (CEE,CSA,JPN)	TD-1067	2
7-12	ZS325495	Tapping Screw #2 3x6		13	7-37x	ZS379350	ISO Screw, pan head 3x6 (CEE,CSA,JPN)		2
7-13	EC520626	MP/C. (3+1)μFx2 250WV AC (Lug Type Uni/D.)	24-9-74	1	7-38x	EF623114	Fuse (SEMKO T Type) 200MAT (C1200MAT (CEE)	39-1-53	1
7-14x	EC641136	MP/C. 4+4 μF 250WV AC (Lug Type Uni/D.) (CEE)	24-9-103	1	CONNECTOR PANEL BLOCK				
7-15x	EC536927	MP/C. 3μFx2 250WV AC (Lug Type Uni/D.) (CSA)	24-9-79	1	7-39	EJ222748	Socket, Sub Magnale #311SG	31-1-39	1
7-16	EC557190	Elect./C. 470μF 160WV (Lug Type)	24-10-88	1	7-40x	MZ302400	Remote Control Socket Mt. Plate	RX-515	1
7-17x	EF623103	Fuse 1AT (SEMKO T Type) (CEE)	39-1-53	5	7-41x	ZS355522	Screw, pan head 3x6		5
7-18x	EF487427	Fuse ULMF61M 250V 0.2A (CSA)	39-1-45	1	7-42x	ML580612	F SW. Table A	TD-2059	1
7-19x	EF511637	Fuse ULMF61M 250V 1A (CSA)	39-1-45	4	7-43	ES479485	Slide SW. S-1	25-3-66	3
7-20x	EF588420	Fuse 1A 125V (JPN)	39-1-52	5	7-44x	ZS422076	Screw, pan head 3x5		4
7-21x	EF654210	Fuse 0.25A 125V (JPN)	29-1-52	1	7-45x	ZS327835	ISO Screw, countersunk head 3x5		2
7-22x	EA642701	Repeater P.C Board (CEE)	33-2-52	1	7-46x	MZ580601	F SW. Plate	TD-2058	1
7-23x	EZ614586	Fuse Table MY (CEE)	MY-2043	1	7-47x	EA597251	Transistor P.C Board	KJ-2049	1
7-24x	ZS379350	ISO Screw, pan head 3x6 (CEE)		2	7-48x	ET621786	Transistor T1P-48	45-1-197	1
7-25x	EC650968	Thermister (SINE) PTH62AR 100M (CEE,CSA,JPN)	45-14-3	2	7-49x	ZS421806	Screw, pan head 3x8		1
					7-50x	ZW516611	Nut M3		1
					7-51	EJ631945	Strain Relief SR-4N-4	2-7-49	1
					7-52x	EZ246936	Strain Relief SR-6W-1 (CEE)	2-7-8	1

8 ILLUSTRATION OF MECH ASSEMBLY BLOCK

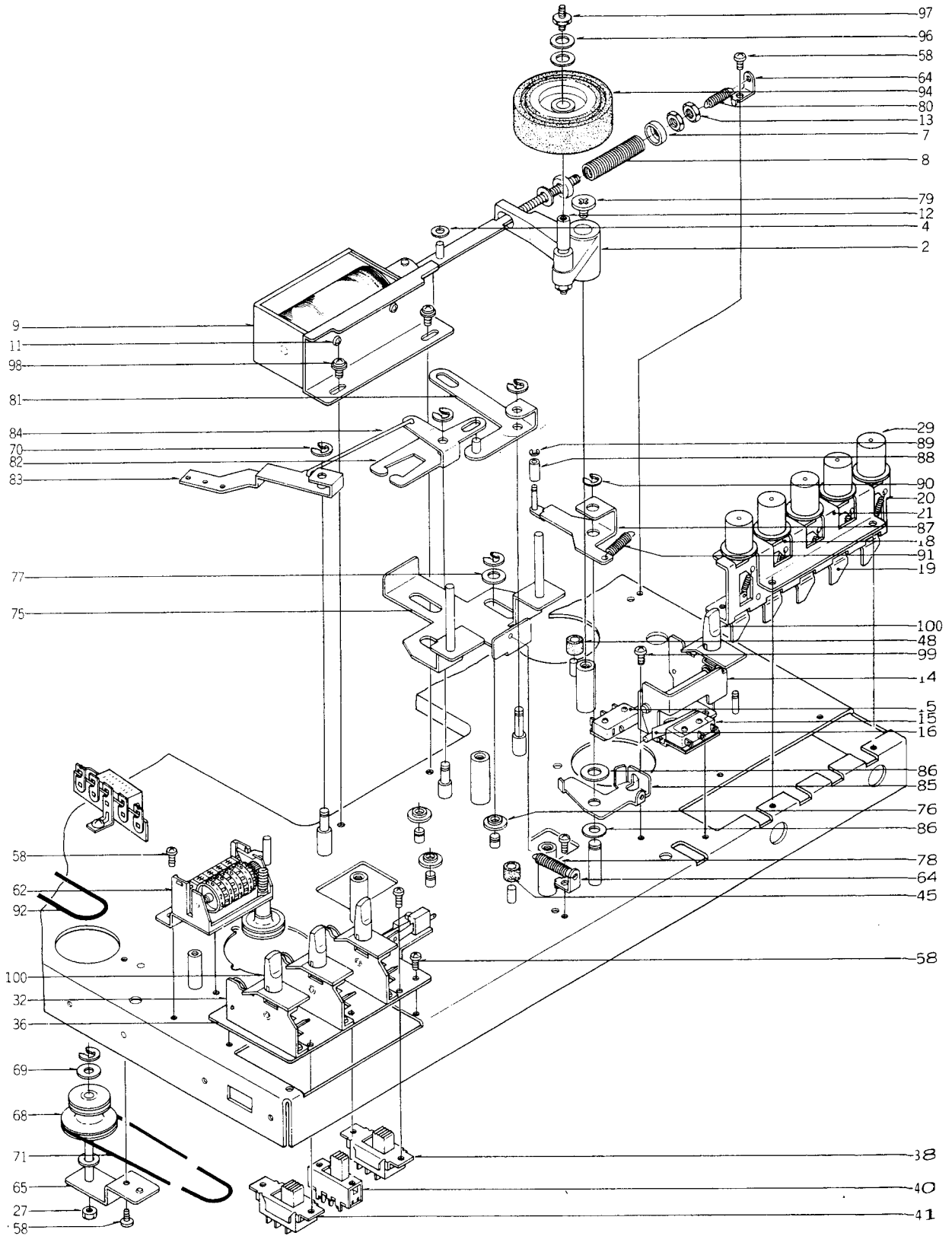

8) MECH ASSEMBLY BLOCK

Ref. No.	Parts No.	Description	Schematic No.	Q'ty	Ref. No.	Parts No.	Description	Schematic No.	Q'ty
PINCH ROLLER PLUNGER BLOCK									
8-1x	BZ637918	Pinch Roller Plunger Block	Comm	1	8-61x	ZW413278	Nut M5		1
8-2	ML300809	Pinch Roller Arm w/shaft	TE	1	8-62	MC638684	Counter MP490-23	9-1-43	1
8-3	MZ580781	Pinch Roller Arm Joint, w/pin	TD-2079	1	8-63x	MZ643443	Counter Base	TE-2011	1
8-4	ZW345442	Washer (Nylon) D4.2x9x1t		1	8-64	MZ582030	Spring Hanger	TD-1018	2
8-5x	MH533913	Connecting Pin	TW-2010	1	8-65	ML580127	Middle Pulley Base	TD-1050	1
8-6x	ZW270088	'E' Ring 1.9M	6-1-9	2	8-66x	MS580116	Middle Pulley Shaft	TD-1049	1
8-7	MZ802980	Spring Holder	RD-276	2	8-67	ZW259773	Washer (Nylon) D4.1x7x0.5t		1
8-8	ZG428927	Pinch Roller Cramp Spring B	KD-1032	1	8-68	MR580105	Middle Pulley, w/metal	TD-1048	1
8-9	EP573658	Plunger Solenoid 1660THT-3	44-1-66	1	8-69	ZW259738	Washer (Polyslider) D4.1x7x0.25t		1
8-10	MZ581275	PK Plunger Bracket	TD-1061	1	8-70	ZW290283	'U' Ring 2.85M	6-1-1	7
8-11	ZS323728	Screw, binding head 3x5		2	8-71	MB580138	Counter Belt D73x1.5	TD-1051	1
8-12	MS582153	Pinch Roller Shaft	TD-1033	1	8-72x	ES250064	Micro SW. V-1A44 U/L	25-1-7	1
8-13	ZW416698	Nut M4		6	8-73x	MZ402377	Micro Insulator D	KD-2050	1
PAUSE SWITCH BLOCK									
8-14	BS637920	Pause Switch Block Comp.	TE	1	8-74x	ZS483502	Screw, pan head 3x13		2
8-15	ES389700	Micro SW. SS-5	25-1-19	2	8-75	MZ636985	Shifter Plate, w/pin B	TD-1028	1
8-16	MZ605283	SW. Actuator	CW-1060	1	8-76	ZW580173	Guide Washer	TD-1055	3
OPERATION BLOCK									
8-17x	BZ637953	Operation Block Comp.	TE	1	8-77	ZW420682	Washer (Nylon) D4.2x9x0.5t		3
8-18	MZ640675	Operation Bracket	TE-2023	1	8-78	ZG582131	Shifter Spring	TD-1030	1
8-19	ML630887	Operation Lever	MY-2202	5	8-79	ZS243516	Screw, pinch roller	XR-140	1
8-20	ZG456120	Setting Lever Spring	CS-1187	5	8-80	ZG580770	Pinch Roller Spring	TD-2078	1
8-21	MZ640383	Operation Holder	TE-2025	1	8-81	ML646198	Shifter Lever, w/pin	TE-1006	1
8-22x	ZS325495	Tapping Screw #2 3x6		6	8-82	ML582096	Shifter Lever B	TD-1025	1
8-23x	EZ640686	P.C Board Support A	TE-2024	1	8-83	ML643847	Spring Lever	TE-1005	1
8-24x	EZ640372	P.C Board Support B	TE-2024	1	8-84	MZ582120	Connecting Bar	TD-1029	1
8-25x	ZS609298	Screw, flat fillister head 3x6		5	8-85	MZ643454	Shifter Lock Arm A	TE-2012	1
8-26x	ZW273802	Toothed Lock Washer M3		5	8-86	ZW403200	Washer (SPC) D6.2x13x1t		1
8-27	ZW516611	Nut M3		13	8-87	MZ643465	Shifter Lock Arm B, w/prop	TE-2013	1
8-28x	SB643500	Button A	TE-2017	1	8-88	MZ580061	Shifter Rock Collar	TD-1044	1
8-29	SB643577	Button B	TE-2017	2	8-89	ZW270088	'E' Ring 1.9M	6-1-9	1
8-30x	SB640732	Button C	TE-2017	1	8-90	ZW270123	'E' Ring 4M	6-1-9	1
8-31x	SB640743	Button D	TE-2017	1	8-91	ZG315011	Brake Lever Spring	MR-116	1
LEVER SWITCH BLOCK									
8-32	BS637997	Lever Switch Block Comp.	TE	1	8-92	MB527556	Counter Belt D93x1.5	ND-1022	1
8-33x	BS660227	Lever Switch Block Comp. (CEE)	TE	1	8-93x	ZG540090	Brake Lever Spring	TW-1058	2
8-34x	BS660238	Lever Switch Block Comp. (CSA)	TE	1	8-94	MP582164	Pinch Roller D=42	TD-1034	1
8-35x	BS660240	Lever Switch Block Comp. (JPN)	TE	1	8-95	ZW430402	Washer (Nylon) D6.2x10x0.5t		1
8-36	MZ643522	SW. Plate	TE-2019	1	8-96	ZW648685	Washer D6.2x10x0.1t		2
8-37	ES563387	Leaf SW. BSW-1A	25-10-19	1	8-97	ZS533766	Pinch Roller Screw	TW-1042	1
8-38	ES479496	Slide SW. S-2	25-3-67	1	8-98	ZS422076	Screw, pan head 3x5		2
8-39x	ES661860	Slide SW. JE1 (CEE)	25-3-63	1	8-99	ZS417216	Screw, pan head 3x4		2
8-40	ES422436	Slide SW. SL-222B4C	25-3-40	1	8-100	SK638976	Knob 1-C	CP-5018	4
8-41	ES479485	Slide SW. S-1	25-3-66	1					
8-42x	ES642677	Slide SW. JE08 (CEE)	25-3-116	1					
8-43x	ES641068	Slide SW. JE06 (CSA,JPN)	25-3-114	1					
MECH. ASSEMBLY BLOCK									
8-44x	ML581883	Shifter Stopper	TD-1002	2					
8-45	MZ810191	Cushion Rubber, RD	RD-278	1					
8-46x	MH581894	Head Base Prop	TD-1003	3					
8-47x	ZS413201	Screw, pan head 4x8		3					
8-48	MB606712	Stopper Rubber KJ	KJ-2060	1					
8-49x	MH581940	Shifter Lever Post A	TD-1008	1					
8-50x	MH581927	Shifter Guide Post	TD-1006	3					
8-51x	MH581951	Spring Lever Post	TD-1010	1					
8-52x	MH581962	Shifter Lever Post B	TD-1011	1					
8-53x	MH581973	Brake Lever Post A	TD-1012	1					
8-54x	MH581984	Brake Lever Post B	TD-1013	1					
8-55x	MH580691	Actuator Prop	TD-2069	1					
8-56x	MH640350	Shifter Lock Arm Prop	TE-1003	1					
8-57x	MH642565	Prop	TE-1002	3					
8-58	ZS379350	ISO Screw, pan head 3x6		11					
8-59x	MS397001	Pinch Roller Arm Shaft	KD-1002	1					
8-60x	ZW664841	Washer D8.1x13x0.3t		1					

9) P.B P.C BOARD (MY-5017) BLOCK

Symbol No.	Parts No.	Description	Q'ty
9-1	BA622732	P.B P.C Board Comp. (MY-5017)	1
9-TR1 to 4	ET234854	Transistor 2SC458LG(C)	8
9-TR5,6	ET639437	Transistor 2SC945L(Q)(P)	4
9-D1	ED570475	Zener Diode WZ-075	2
9-D2	ED219464	Germanium Diode 1N34A	2
9-L1	EO496361	Inductor 6070GE 23MH(J)	2
9-T1	BT517274	Headphone Trans. N16-535S	2
9-VR1	EV464220	Semi-fixed/Vol. V8K4-1 50 k Ω	2
9-VR2	EV622056	Co-axial 2-throw Vol. V24L5GPHN B10kx2	1
9-VR3	EV464196	Semi-fixed/Vol. V8K4-1 2 k Ω	2
Capacitor, Vertical Type			
9-C1	EC220678	Elect. 47 μ F 25WV	2
9-C2	EC432810	Elect. 10 μ F 16WV NL	2
9-C3	EC290520	VFM 100PF(J) 50WV	2
9-C4	EC467133	VFM 68PF(J) 50WV	2
9-C5	EC290520	VFM 100PF(J) 50WV	2
9-C6	EC329771	Elect. 47 μ F 6.3WV	2
9-C7	EC320051	Elect. 10 μ F 16WV	2
9-C8	EC389485	Mylar 0.018 μ F(J) 50WV	2
9-C9,10	EC250683	Mylar 0.0022 μ F(J) 50WV	4
9-C11	EC220678	Elect. 47 μ F 25WV	2
9-C12	EC329850	VFM 220PF(J) 50WV	2
9-C13	EC432810	Elect. 10 μ F 16WV NL	2
9-C14	EC329771	Elect. 47 μ F 6.3WV	2
9-C15	EC399565	FM 22PF(J) 50WV	2
9-C16	EC290520	VFM 100PF(J) 50WV	2
9-C17	EC320051	Elect. 10 μ F 16WV	2
9-C18	EC220364	Elect. 100 μ F 6.3WV	2
9-C19	EC450055	Elect. 1 μ F 25WV	2
9-C20	EC320051	Elect. 10 μ F 16WV	2
9-C21	EC450527	Elect. 4.7 μ F 25WV	2
9-C22	EC329771	Elect. 47 μ F 6.3WV	2

Carbon Resistor Omitted

10) REC, OSC P.C BOARD(MY-5016)BLOCK

Symbol No.	Parts No.	Description	Q'ty
10-1	BA647684	Rec., Osc. P.C Board Comp. (MY-5016)	1
10-2	BA647842	Rec., Osc. P.C Board Comp. (MY-5016)(DB)	1
10-TR1,2	ET234854	Transistor 2SC458LG(C)	4
10-TR3,4	ET234854	Transistor 2SC458LG(C)	4
10-TR5,6,7	ET639437	Transistor 2SC945L(Q)(P)	4
10-L1	EO321254	Ferri Inductor FL7H 5.6MH(J)	2
10-L2	EO383365	OSC. Coil OT-204	1
10-VR1	EV622078	Double Vol. V24L5DPHN A50kx2	2
10-VR2	EV520806	Semi-fixed/Vol. V8K4-1 10 k Ω	2
10-R39	ER515070	Metal Oxide Film/R. 2W 150 ohm(K)	1
10-R40	ER426892	Solid/R. RC1/2 2.4k(J)	1
Capacitor, Vertical Type			
10-C1	EC290520	VFM 100PF(J) 50WV	2
10-C2	EC220678	Elect. 47 μ F 25WV	2
10-C3	EC432810	Elect. 10 μ F 16WV NL	2
10-C4	EC290520	VFM 100PF(J) 50WV	2
10-C5	EC220364	Elect. 100 μ F 6.3WV	2
10-C6,7	EC399565	FM 22PF(J) 50WV	4
10-C8	EC320051	Elect. 10 μ F 16WV	2
10-C9	EC329771	Elect. 47 μ F 6.3WV	2
10-C10	EC377212	VFM 47PF(J) 50WV	2
10-C11	EC320051	Elect. 10 μ F 16WV	2
10-C12	EC220678	Elect. 47 μ F 25WV	2
10-C13	EC329771	Elect. 47 μ F 6.3WV	2
10-C14	EC399565	FM 22PF(J) 50WV	2
10-C15	EC290520	VFM 100PF(J) 50WV	2

Symbol No.	Parts No.	Description	Q'ty
10-C16	EC438041	Mylar 0.082 μ F(J) 50WV	2
10-C17	EC320051	Elect. 10 μ F 16WV	2
10-C18	EC329771	Elect. 47 μ F 6.3WV	2
10-C19	EC368357	Mylar 0.056 μ F(J) 50WV	2
10-C20	EC220151	Elect. 100 μ F 25WV	2
10-C21	EC320051	Elect. 10 μ F 16WV	2
10-C22	EC220994	Elect. 10 μ F 25WV	2
10-C23	EC405898	Styrol 470PF(J) 50WV	2
10-C24	EC250841	Mylar 0.01 μ F(J) 50WV	2
10-C25	EC558202	Trimmer TM-80A 80PF	2
10-C26	EC558235	Styrol 1800PF(J) 250WV	1
10-C27,28	EC250975	Mylar 0.015 μ F(J) 50WV	2
10-C29	EC220612	Elect. 33 μ F 25WV	1

Carbon Resistor Omitted

11) DOLBY P.C BOARD (TD-5301) BLOCK

Symbol No.	Parts No.	Description	Q'ty
11-1	BA588003	Dolby P.C Board Comp. (TD-5301)	1
11-TR1	ET234854	Transistor 2SC458LG(C)	2
11-TR2	ET329218	Transistor 2SC458(C)	2
11-TR3	ET352146	Transistor 2SC458LG(D)	2
11-TR4	ET329218	Transistor 2SC458(C)	2
11-TR5	ET491051	FET 2SK30A(GR)	2
11-TR6	ET234854	Transistor 2SC458LG(C)	2
11-TR7	ET350335	Transistor 2SA564(Q)	2
11-TR8	ET329218	Transistor 2SC458(C)	2
11-D1	ED219464	Germanium Diode 1N34A	2
11-D2	ED491130	Zener Diode WZ-083	2
11-D3,4	ED560913	Silicon Diode 1S2473 VE	4
11-D5	ED219464	Germanium Diode 1N34A	2
11-D6	ED560913	Silicon Diode 1S2473 VE	2
11-VR1	EV478686	Semi-fixed/Vol. V8K4-1 1 k Ω	2
11-BR2	EV464207	Semi-fixed/Vol. V8K4-1 5 k Ω	2
11-L1	EO496350	Inductor 146LY 36 MH(J)	2
11-2	EJ363126	P.C Board Terminal	2

Capacitor, Vertical Type

11-C1	EC320051	Elect. 10 μ F 16WV	2
11-C2	EC350875	Mylar 0.001 μ F(J) 50WV	2
11-C3	EC336194	VFM 270PF(J) 50WV	2
11-C4,5	EC320051	Elect. 10 μ F 16WV	4
11-C6	EC320051	Elect. 10 μ F 16WV	2
11-C7	EC313121	Elect. 220 μ F 25WV	2
11-C8	EC329883	Mylar 0.0056 μ F(J) 50WV	2
11-C9	EC329861	Mylar 0.027 μ F(J) 50WV	2
11-C10	EC337500	Mylar 0.0047 μ F(J) 50WV	2
11-C11	EC320051	Elect. 10 μ F 16WV	2
11-C12	EC379170	Mylar 0.1 μ F(J) 50WV	2
11-C13	EC320040	Elect. 47 μ F 16WV	2
11-C14	EC290520	VFM 100PF(J) 50WV	2
11-C15	EC320051	Elect. 10 μ F 16WV	2
11-C16	EC379170	Mylar 0.1 μ F(J) 50WV	2
11-C17	EC320051	Elect. 10 μ F 16WV	2
11-C18	EC379170	Mylar 0.1 μ F(J) 50WV	2
11-C19	EC379170	Mylar 0.1 μ F(J) 50WV	2
11-C20	EC395504	Mylar 0.33 μ F(K) 50WV	2

Carbon Resistor Omitted

12) SRT P.C BOARD (TD-5201) BLOCK

Symbol No.	Parts No.	Description	Q'ty
12-1	BA647796	SRT P.C Board Comp. (TD-5201)	1
12-2	BA647763	SRT P.C Board Comp. (TD-5201)(DB)	1
12-SW1	ES550001	Push SW. 1FS-6U-49	1
12-L1	EO369178	Ferri Inductor FL7H 1.5 MH(J)	2
12-VR1,2	EV520806	Semi-fixed/Vol. V8K4-1 10 KB (DB)	4
Capacitor, Vertical Type			
12-C1	EC329861	Mylar 0.027 μ F(J) 50WV	2
12-C2	EC379214	Mylar 0.047 μ F(J) 50WV	2
12-C3	EC368335	Mylar 0.022 μ F(J) 50WV	2
12-C4	EC379214	Mylar 0.047 μ F(J) 50WV	2
12-C5	EC379192	Mylar 0.039 μ F(J) 50WV	2

Carbon Resistor Omitted

13) SYS. CON P.C BOARD (TE-2001) BLOCK

Symbol No.	Parts No.	Description	Q'ty
13-1	BA637964	Sys. Con. P.C Board Comp. (TE-2001)	1
13-TR1	ET639437	Transistor 2SC945L(Q)(P)	1
13-TR2,3	ET511920	Transistor 2SC1247A(B)(V)	2
13-TR4to6	ET639437	Transistor 2SC945L(Q)(P)	3
13-TR7	ET399881	Transistor 2SC711(F)	1
13-TR8to11	ET639437	Transistor 2SC945L(Q)(P)	4
13-D1to3	ED560913	Silicon Diode 1S2473 VE	3
13-D4	ED494583	Silicon Diode 10D05	1
13-D5to10	ED560913	Silicon Diode 1S2473 VE	6
13-D11	ED498150	Zener Diode WZ-192	1
13-D12,13	ED560913	Silicon Diode 1S2473 VE	2
13-D14to29	ED624903	Silicon Diode 1S2473	16
Capacitor, Vertical Type			
13-C1	EC459505	Mylar 0.039 μ F(K) 50WV	1
13-C2	EC350684	Elect. 22 μ F 25WV	1
13-C3	EC362158	Mylar 0.0047 μ F(K) 50WV	1
13-C4	EC350684	Elect. 22 μ F 25WV	1
13-C5	EC220612	Elect. 33 μ F 25WV	1
13-C6	EC350684	Elect. 22 μ F 25WV	1
13-C7	EC251087	Mylar 0.022 μ F(K) 50WV	1
13-C8	EC368256	Elect. 0.47 μ F 25WV	1

Carbon Resistor Omitted

14) SERVO P.C BOARD (MY-2036) BLOCK

Symbol No.	Parts No.	Description	Q'ty
14-1	BA657167	Servo P.C Board Comp. (MY-2036)	1
14-TR1,2	ET639437	Transistor 2SC945(P)(Q)	2
14-TR3,4	ET399886	Transistor 2SC945(Q)	2
14-TR5	ET538154	Transistor 2SA564(Q)(R)	1
14-TR6	ET399886	Transistor 2SC945(Q)	1
14-TR7	ET623867	Transistor 2SD361(D1)(D2)	1
14-TR8	ET639437	Transistor 2SC945(P)(Q)	1
14-D1	ED557447	Silicon Diode 1S1588	1
14-D2to5	ED224548	Silicon Diode 10D2	4
14-TH1	ED593357	Thermister 34D21	1
14-VR1	EV621955	Semi-fixed/Vol. V10K8-1-5 B10K	1
14-VR2	EV621966	Semi-fixed/Vol. V10K8-1-5 B30K	1
14-2	ZS421806	Screw, pan head 3x8	1
14-3	ZW273756	Nut M3	1
14-4	EZ615047	Heat-sink Plate A	1
14-5	ZS422076	Screw, pan head 3x5	6

Symbol No.	Parts No.	Description	Q'ty
14-6	EZ615060	P.C Board Holder B	1
14-7	EZ615071	P.C Board Holder C	1
14-R20	ER593346	Cement/R. 2W 330 ohm(K) (Wire-wound Type)	1
Capacitor, Vertical Type			
14-C1	EC251291	Mylar 0.1 μ F(K) 50WV	1
14-C2	EC251122	Mylar 0.027 μ F(K) 50WV	1
14-C3	EC250582	Mylar 0.0033 μ F(K) 50WV	1
14-C4	EC331828	Elect. 3.3 μ F 25WV	1
14-C5	EC251122	Mylar 0.027 μ F(K) 50WV	1
14-C6	EC250582	Mylar 0.0033 μ F(K) 50WV	1
14-C7	EC311793	Mylar 0.012 μ F(J) 50WV	1
14-C8	EC557166	Solid Aluminum 3.3 μ F 25WV	1
14-C9	EC450055	Elect. 1 μ F 25WV	1
14-C10	EC320051	Elect. 10 μ F 16WV	1
14-C11	EC220151	Elect. 100 μ F 25WV	1
14-C12	EC250885	Mylar 0.01 μ F(K) 50WV	1
14-C13	EC346735	Elect. 47 μ F 50WV	1

Carbon Resistor Omitted

15) RELAY P.C BOARD (TE-2002) BLOCK

Symbol No.	Parts No.	Description	Q'ty
15-1	BA638021	Relay P.C Board Comp. (TE-2002)	1
15-TR1	ET537300	Transistor 2SD361(D)(E)	1
15-TR2	ET511920	Transistor 2SC1247A(B)(V)	1
15-TR3	ET639437	Transistor 2SC945L(Q)(P)	1
15-TR4	ET517353	Transistor 2SC711(E)(G)	1
15-D1to5	ED570273	Silicon Diode 1N4004	5
15-D6to9	ED511097	Silicon Diode 1N4001	4
15-D10	ED357794	Zener Diode RD-5A(M)	1
15-D11,12	ED560913	Silicon Diode 1S2473 VE	2
15-D13to16	ED624903	Silicon Diode 1S2473	4
15-D17,18	ED560913	Silicon Diode 1S2473 VE	2
15-CR1to10	ER450786	Spark Quencher U/L 0.1 μ +120 ohm 400WV	10
15-VR1	EV498071	Semi-fixed/Vol. V10K8-1-5 1 kB	1
15-RL1	EP616500	Relay LC1-C-JT DC24V	1
15-RL2	EP638763	Relay MY4-0-US DC24V	1
15-RL3	EP616500	Relay LC1-C-JT DC24V	1
15-RL4	EP638763	Relay MY4-0-US DC24V	1
15-2	EZ640462	Relay P.C Board Retaining Part	1
15-3	ZS325495	Tapping Screw #2 3x6	6
15-4	EZ640642	Relay P.C Board Retaining Part B	1
15-5	ZS421806	Screw, pan head 3x8	1
15-6	ZW516993	Nut M3	1
15-R1	ER535948	Cement/R. 5W 10 ohm(K) (Wire-wound Type)	1
15-R3	ER563354	Cement/R. 15W 430 ohm(K) (Metal OX. Film Type)	1
15-R4	ER641261	Cement/R. 20W 43 ohm(K) (Wire-wound Type)	1
15-R5	ER573524	Cement/R. 10W 150 ohm(K) (Wire-wound Type)	1
15-R20	ER372082	Cement/R. 2W 100 ohm(K) (Wire-wound Type)	1
Capacitor, Vertical Type			
15-C1,2	EC350987	MP/C. 0.47 μ F(M) 250V DC (Tub. Type)	2
15-C3	EC565345	Elect. 1000 μ F 50WV	1
15-C4	EC372148	Elect. 220 μ F 35WV	1
15-C5	EC250918	Mylar 0.01 μ F(M) 50WV	1
15-C6	EC313121	Elect. 220 μ F 25WV	1
15-C7	EC331705	Elect. 22 μ F 16WV	1
15-C8,9	EC220678	Elect. 47 μ F 25WV	2
15-C10	EC646031	Elect. 4.7 μ F 160WV (Tub. Type)	1

Carbon Resistor Omitted

16) REC MODE P.C BOARD(TE-5003)BLOCK

Symbol No.	Parts No.	Description	Q'ty
16-1	BZ647831	Rec. Mode P.C Board Comp. (TE-5003)	1
16-D1	ED624903	Silicon Diode 1S2473	1
16-SW3	ES640541	Push SW. 2FT-0014FF1320	1
16-RL1	EP383321	Relay TECK-36 DC22V 1000 ohm	1
16L1,2	EO390622	Ferri Inductor FL9H 220 μ H(K)	2
16-2	EZ640451	SW. Shield	1
16-3	ZS379350	ISO Screw, pan head 3x6	1
16-4	ZW516611	Nut M3	1
16-5	ZW273802	Toothed Lock Washer M3	1

17) SPEED SWITCH P.C BOARD (TE-5001) BLOCK

Symbol No.	Parts No.	Description	Q'ty
17-1	BA647717	Speed Switch P.C Board Comp. (TE-5001)	1
17-SW2	ES640552	Slide SW. SSA06207	1
17-L1	EO379923	Ferri Inductor FL7H 8.2 MH(J)	2
17-2	MZ640618	Equalizer Bracket	1
17-3	ZS432843	Screw, pan head 2.6x4	2
17-C1	EC250841	Mylar/C. 0.01 μ F(J) 50WV (Vert. Type)	2
Carbon Resistor Omitted			

2. GX-630D/DB

Name and parts number of Speed Switch P.C Board changed as follows:

Speed Switch P.C Board Comp. TE-5001 BA647717
 changed to
 Speed Switch Block Comp. TE-5001 BS647717

18 PHOTO OF AMP ASSEMBLY BLOCK

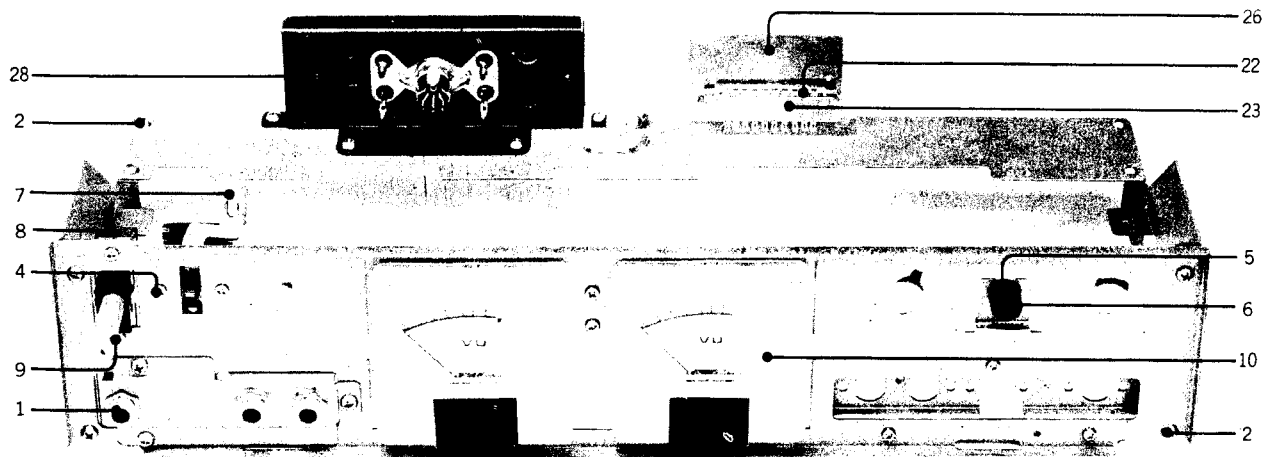

18) AMP ASSEMBLY BLOCK

Ref. No.	Parts No.	Description	Schematic No.	Q'ty	Ref. No.	Parts No.	Description	Schematic No.	Q'ty
FRONT CHASSIS BLOCK									
18-1	EJ655830	3-throw Jack C	31-2-69	1	18-31x	ER214290	Carbon/R. RD1/4 4.7k(J) (Insu. Type)	35-9-5	2
18-2	ZS325495	Tapping Screw #2 3x6		12	18-32x	ER345677	Carbon/R. RD1/4 15k(J) (Insu. Type)	35-9-5	2
18-3x	MZ640405	SW. Retaining Plate	TE-5007	1	18-33x	ER324685	Carbon/R. RD1/4 33k(J)	35-9-5	2
18-4	ZS422076	Screw, pan head 3x5		2	AMP ASSEMBLY BLOCK				
18-5	EZ586326	Lamp Holder	LF-5324	1	18-34x	EJ639112	9P Plug Housing 103-3-9P	42-1-85	1
18-6	EL639472	Lamp 24V 35MA(190M/Mx2) (Read Type)	28-2-24	1	18-35x	EJ514607	Wire Clip 220-JD485210-01 (Nylon)	2-7-18	2
18-7	MZ640945	Connecting Plate B	TE-5009	1	18-36x	EJ510333	Wire Clip 220-JD481610- 0104 (Nylon)	2-7-17	3
18-8	ES641283	Lever SW. S-J6399	25-12-21	1	18-37x	MT553948	Wire Band B	2-35-3	4
18-9	ZS379350	ISO Screw, pan head 3x6		4	18-38x	MZ640440	Jack Plate Holder	TE-5014	1
18-10	EM573748	VU Meter KL-280B-28 (Yellow)	46-1-86	2					
18-11x	MZ659632	Meter Mask	TE-5027	2					
18-12x	ZG290878	VU Meter Spring	DX-504	4					
18-13x	ZW516611	Nut M3		4					
18-14x	EZ640620	P.C Board Holder	TE-5011	1					
18-15x	ES573671	Push SW. 1FST-6U-122-3 (DB)	25-5-119	1					
18-16x	ZS422076	Screw, pan head 3x5 (DB)		2					
18-17x	EA640438	Dolby Lamp P.C Board (DB)	TE-5004	1					
18-18x	EL619064	Lamp 24V 35MA (DB)	28-2-40	1					
18-19x	ZS325495	Tapping Scres #2 3x6		1					
REAR CHASSIS BLOCK									
18-20x	MZ640574	Amp. Side Plate A	TE-5012	1					
18-21x	MZ640585	Amp. Side Plate B	TE-5012	1					
18-22	EJ292961	Multi-jack 10P 500-010-005	31-4-4	1					
18-23	EZ530021	Jack Nut Plate	ND-5052	1					
18-24x	ZS462947	Screw, pan head 2.3x12		2					
18-25x	ZW273881	Earth Lug M4		1					
18-26	EZ655942	MJJack Shield	TE-5017	1					
JACK PLATE BLOCK									
18-27x	BJ647728	Jack Plate Block Comp.		1					
18-28	EJ624104	Jack Plate J-2	31-5-121	1					
18-29x	EA628222	P.C Board for Jack	LE-5622	1					
18-30x	ER440921	Carbon/R. RD1/4 27k(J) (Insu. Type)	35-9-5	2					

19 PHOTO OF FINAL ASSEMBLY BLOCK

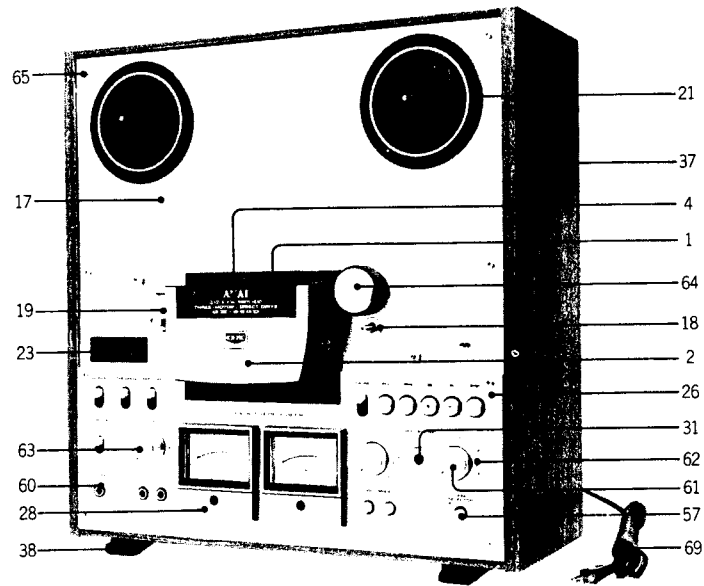

19) FINAL ASSEMBLY BLOCK

Ref. No.	Parts No.	Description	Schematic No.	Q'ty	Ref. No.	Parts No.	Description	Schematic No.	Q'ty
HEAD COVER TABLE BLOCK					CASE BLOCK				
19-1	SC640991	Head Cover Base	TE-6007	1	19-36x	BC647673	Case Block Comp.	TE	1
19-2	SC643724	Head Cover	TY-6004	1	19-37	BC640978	Wood Case	TE-6001	1
19-3x	SZ534543	Cushion Rubber C	TW-6039	2	19-38	SA640934	Square Foot, w/rubber	TE-6000	2
19-4	SM640956	Model Name Plate GX-630D	TE-6005	1	19-39x	ZS200610	Tapping Screw #1 4x12 (Truss)		4
19-5x	SM640967	Model Name Plate GX-630DB (DB)	TE-6005	1	19-40x	SZ480712	Dust Cover Pin	LE-6004	2
19-6x	MZ640800	Hinge Bracket	TE-6006	1	FINAL ASSEMBLY BLLCK				
19-7x	MZ598263	Hinge Angel	KJ-6017	1	19-41x	SP641024	Lower Side Plate A	TE-6003	1
19-8x	MV269965	Steel Ball D4		1	19-42x	SP641035	Lower Side Plate B	TE-6003	1
19-9x	ZG249107	Ball Retaining Spring	RD-632	1	19-43x	ZS325495	Tapping Screw #2 3x6		30
19-10x	ZW499593	Set Screw, hexagon socket 5x4 (Flat Point)		1	19-44x	SP641046	Upper Side Plate A	TE-6004	1
19-11x	MS597431	Hinge Shaft	KJ-6015	1	19-45x	SP641057	Upper Side Plate B	TE-6004	1
19-12x	SZ597420	Collar	KJ-6014	1	19-46x	MZ640877	Supporting Plate	TE-6005	2
19-13x	ZW420682	Washer (Nylon) D4.2x9x0.5t		1	19-47x	ZS417150	Screw, pan head 4x6		8
19-14x	ZW270101	'E' Ring 3M	6-1-9	2	19-48x	SZ529920	Reinforcement Angle A	ND-6000	1
19-15x	ZS323728	Screw, binding head 3x5		4	19-49x	ZS432674	Screw, pan head 3x3		1
MECH. PANEL BLOCK					19-50x	SA428714	LM Rubber Foot, w/screw	LM-400	4
19-16x	BZ647662	Mech. Panel Block Comp.	TE	1	19-51x	ZW324281	Screw, pan head 4x25		4
19-17	SP641237	Mech. Panel	TE-6001	1	19-52x	ZW419646	Washer (SPC) D4.5x9.8x0.5t		4
19-18	SE640754	Motor Escutcheon A	TE-6002	1	19-53x	ZS665550	Screw, pan head 4x15, w/washer		2
19-19	MZ640787	Impedance Roller Collar	TE-6003	1	19-54x	ZS664345	Screw, pan head 4x30 w/washer		4
19-20x	MZ640798	Arm Collar	TE-6004	2	19-55x	EZ640980	Amp. Shield	TE-6000	1
19-21	SE581602	Reel Table Escutcheon 2	TD-6021	2	19-56	SK638976	Knob 1-C	CP-5000	4
19-22x	ZW575730	Speed Nut (P Type) 3	6-3-6	8	19-57	SK634410	Push Button Knob J	91-5050	3
19-23	SE626951	Counter Escutcheon	MY-6006	1	19-58x	EF563681	Fuse 1A250V	39-1-50	1
AMP. PANEL BLOCK					19-59x	ZS411660	Screw, oval countersunk head 3x6		2
19-24x	BZ647730	Amp. Panel Block Comp.	TE	1	19-60	EZ436217	Collar For Jack	MC-5000	3
19-25x	BZ647741	Amp. Panel Block Comp. (DB)	TE	1	19-61	SK640912	Double Knob (Upper)	TE-6001	2
19-26	SP641002	Amp. Panel	TE-6008	1	19-62	SK640923	Double Knob (Lower)	TE-6001	2
19-27x	SP641013	Amp. Panel (DB)	TE-6008	1	19-63	SK640901	Single Knob	TE-6001	1
19-28	SE631102	VU Escutcheon	MY-6205	2	19-64	SK645300	Pinch Roller Cap	TD-6001	1
19-29x	ZS575392	Screw, pan head 2.6x8		8	19-65	ZS613901	Panel Screw	CW-6001	8
19-30x	ZW318014	Washer (BSP) D2.6x4.5x0.4t		8	19-66x	ZS312221	Screw, truss head 3x15 (Black)		4
19-31	SE612055	Lamp Lens A (Red)	CH-6314	1	19-67x	SE627120	Ventilator	MY-6001	1
19-32x	SE639696	Lamp Lens B-2 (DB)	NE-6005	1	19-68x	ZS392141	Tapping Screw #1 3x8 (Truss)		2
19-33x	SE613888	Button Escutcheon A (DB)	CW-6021	4	19-69	EW374894	AC Cord 3M	26-3-10	1
19-34x	SE613866	Button Escutcheon C	CW-6016	5	19-70x	EW516600	AC Cord VM-0065 (CEE)	26-3-20	1
19-35x	TC494267	Lamp Cover(DB)	CG-2206	1	19-71x	EW524845	AC Cord 2.5M (JPN)	26-3-30	1

20 LIST OF INTERCHANGEABLE SEMICONDUCTORS

As far as service in concerned, in case the original parts cannot be obtained, the interchangeable parts listed below can be substituted.

Original Parts			Interchangeable Parts	
Description	Parts No.	Utilizing P.C Board	Description	Parts No.
2SA564 (Q)	ET350335	MY-2036 TD-5301	2SA733 (Q),(R) 2SA628 (D),(E) 2SA640 (E),(F)	ET538378 ET538110 ET623790
2SC458 (C)	ET329218	TD-5301	2SC458LG (C) 2SC693U (F)	ET234854 ET315472
2SC458LG (C)	ET234854	MY-5016 MY-5017 TD-5301	2SC693U (F) 2SC1312R (G),(H) 2SC1312S (G),(H)	ET315472 ET610413 ET603257
2SC711 (F),(G)	ET398777	TE-2001 TE-2002	2SC536 (E),(F) 2SC945 (E),(F)	ET370607 ET398711
2SC945L (Q),(P)	ET639437	MY-2036 MY-5016 MY-5017 TE-2001 TE-2002	2SC711 (E),(F) 2SC1647 (R)(S)(E) 2SC1641 (R)(S)(E)	ET453486 ET623733 ET603843
2SC1247A (B),(V)	ET511920	TE-2001 TE-2002	2SC1211 (D),(E)	ET511694
2SD361 (D),(E)	ET537000	TE-2002	2SD361 (D1),(D2) 2SC1061 (B),(C) 2SC1449 (K)(L)(H)	ET623867 ET375603 ET635815
TIP47	ET621775		TIP48	ET621786
1N34A	ED219464	MY-5017	1N60	ED428264
1N4001	ED511097	TE-2002	10D05	ED494583
1S1588	ED557447	MY-2036	1S2473 WG599 1S2473VE	ED624903 ED514721 ED560913
1S2473	ED624903	TD-5301	1S1588	ED557447
1S2473VE	ED560913	TE-2001 TE-2002	WG599 WG713	ED514721 ED515790

INDEX

Parts No.	Ref. No. & Symbol No.	Parts No.	Ref. No. & Symbol No.	Parts No.	Ref. No. & Symbol No.	Parts No.	Ref. No. & Symbol No.	Parts No.	Ref. No. & Symbol No.
BA588003	11-1	EC320051	10-C11	ED560913	11-D3,4	ES624677	8-42x	MC638684	8-62
BA622732	9-1	EC320051	10-C17	ED560913	11-D6	ES661860	8-39x	MH244710	6-6
BA637964	13-1	EC320051	10-C21	ED560913	13-D1to3	ET234854	9-TH1to4	MH257477	5-7
BA638021	15-1	EC320051	11-C1	ED560913	13-D5to10	ET234854	10-TR1,2	MH529233	1-11
BA647684	10-1	EC320051	11-C4,5	ED560913	13-D12,13	ET234854	10-TR3,4	MH533913	8-5x
BA647717	17-1	EC320051	11-C6	ED560913	15-D11,12	ET234854	11-TR1	MH578957	1-6
BA647763	12-2	EC320051	11-C11	ED560913	15-D17,18	ET234854	11-TR6	MH580588	6-7
BA647842	10-2	EC320051	11-C15	ED570273	5-4x	ET329218	11-TR2	MH580691	8-55x
BA647796	12-1	EC320051	11-C17	ED570273	15-D1to5	ET329218	11-TR4	MH581894	8-46x
BA651667	14-1	EC320051	14-C10	ED570475	9-D1	ET329218	11-TR8	MH581927	8-50x
BC640978	19-37	EC329771	9-C6	ED593357	14-TH1	ET350335	11-TR7	MH581940	8-49x
BC647673	19-36x	EC329771	9-C14	ED624903	13-D14to29	ET352146	11-TR3	MH581951	8-51x
BH638008	1-1x	EC329771	9-C22	ED624903	15-D13to16	ET399846	14-TR3,4	MH581962	8-52x
BI637931	4-1x	EC329771	10-C9	ED624903	16-D1	ET399846	14-TR6	MH581973	8-53x
BJ647728	18-27x	EC329771	10-C13	EF487427	7-18x	ET399881	13-TR7	MH581984	8-54x
BM587518	3-1	EC329771	10-C18	EF511637	7-19x	ET491051	11-TR5	MH640350	8-56x
BM637975	2-1x	EC329850	9-C12	EF563681	19-58x	ET511920	13-TR2,3	MH642565	8-57x
BR587542	3-6x	EC329861	11-C9	EF588420	7-20x	ET511920	15-TR2	MI597183	4-18
BR587553	3-7x	EC329861	12-C1	EF623103	7-17x	ET517353	15-TR4	ML396933	8-2
BS637920	8-14	EC329883	11-C8	EF623114	7-38x	ET537300	15-TR1	ML533643	5-12
BS637997	8-32	EC331705	15-C7	EF654210	7-21x	ET538154	14-TR5	ML580127	8-65
BS660227	8-33x	EC331828	14-C4	EJ222748	7-39	ET621786	7-48x	ML580443	6-1
BS660238	8-34x	EC336194	11-C3	EJ233370	7-33	ET623867	14-TR7	ML580465	6-24
BS660240	8-35x	EC337500	11-C10	EJ292961	18-22	ET639437	9-TR5,6	ML580555	6-10
BT517274	9T-1	EC346735	14-C13	EJ315101	1-26	ET639437	10-TR5,6,7	ML580612	7-42x
BT640517	7-1	EC350684	13-C2	EJ363126	11-2	ET639437	13-TR1	ML581883	8-44x
BT661858	7-2x	EC350684	13-C4	EJ510333	7-32x	ET639437	13-TR4to6	ML582041	5-18
BT661904	7-4x	EC350684	13-C6	EJ510333	18-36x	ET639437	13-TR8to11	ML582074	5-16
BT661926	7-3x	EC350875	11-C2	EJ514607	18-35x	ET639437	14-TR1,2	ML582096	8-82
BZ600300	2-5	EC350987	15-C1,2	EJ624104	18-28	ET639437	14-TR8	ML630887	8-19
BZ637918	8-1x	EC362158	13-C3	EJ631945	7-51	ET639437	15-TR3	ML643476	5-6
BZ637953	8-17x	EC368256	13-C8	EJ639112	18-34x	EV464196	9-VR3	ML643487	5-9
BZ637936	5-1x	EC368335	12-C3	EJ654221	7-26x	EV464207	11-VR2	ML643847	8-83
BZ647662	19-16x	EC368357	10-C19	EJ655830	18-1	EV464220	9-VR1	ML646198	8-81
BZ647730	19-24x	EC372148	15-C4	EL619064	18-18x	EV478686	11-VR1	MP582164	8-94
BZ647741	19-25x	EC377212	10-C10	EL639472	18-6	EV498071	15-VR1	MR580105	8-68
BZ647831	16-1	EC379170	11-C12	EM573748	18-10	EV520806	10-VR2	MS597115	4-15
EA597251	7-74x	EC379170	11-C16	EO321254	10-L1	EV520806	12-VR1,2	MR342000	3-15
EA628222	18-29x	EC379170	11-C18	EO369178	12-L1	EV621955	14-BR1	MS397001	8-59x
EA640438	18-17x	EC379170	11-C19	EO379923	17-L1	EV621966	14-VR2	MS580116	8-66x
EA642701	7-22x	EC379192	12-C5	EO383365	10-L2	EV622056	9-VR2	MS582153	8-12
EC220151	10-C20	EC379214	12-C2	EO390622	16-L1,2	EV622078	10-VR1	MS597431	19-11x
EC220151	14-C11	EC379214	12-C4	EO496350	11-L1	EW374894	19-69	MS597655	2-10
EC220364	9-C18	EC389485	9-C8	EO496361	9-L1	EW516600	19-70x	MS643397	4-10
EC220364	10-C5	EC395504	11-C20	EP383321	16-RL1	EW524845	19-71x	MS645502	6-2
EC220612	10-C29	EC399565	9-C15	EP573658	8-9	EZ246936	7-52x	MT314987	5-13
EC220612	13-C5	EC399565	10-C6,7	EP616500	15-RL1	EZ436217	19-60	MT317485	3-11x
EC220678	9-C1	EC399565	10-C14	EP616500	15-RL3	EZ530021	18-23	MT436860	3-10
EC220678	9-C11	EC405898	10-C14	EP638695	5-3	EZ586326	18-5	MT534666	3-13
EC220678	10-C2	EC432810	9-C2	EP638763	15-RL2	EZ614586	7-23x	MT534677	3-14
EC220678	10-C12	EC432810	9-C13	EP638763	15-RL4	EZ615047	14-4	MT534688	3-17
EC220678	15-C8,9	EC432810	10-C	ER214290	18-31x	EZ615060	14-6	MT553948	7-31x
EC220994	10-C22	EC438041	10-C16	ER324685	18-33x	EZ615071	14-7	MT553948	18-37x
EC250582	14-C6	EC450055	9-C19	ER345677	18-32x	EZ78862	2-16	MT577473	3-8
EC250582	14-C3	EC450055	14-C9	ER372082	15-R20	EZ640372	8-24x	MV269965	4-23
EC250683	9-C9,10	EC450527	9-C21	ER426892	10-R40	EZ640451	16-2	MV269965	19-8x
EC250841	10-C24	EC459505	13-C1	ER440921	18-30x	EZ640462	15-2	MV368886	2-6
EC250841	17-C1	EC467133	9-C4	ER450786	5-28	EZ640620	18-14x	MV408510	3-2x
EC250885	14-C12	EC520626	7-13	ER450786	15-CR1to10	EX640642	15-4	MV643386	4-3
EC250918	15-C5	EC536927	7-15x	ER515070	10-R39	EZ640686	8-23x	MZ248185	3-3
EC250975	10-C27,28	EC557166	14-C8	ER535948	15-R1	EZ640980	19-55x	MZ302400	7-40x
EC251087	13-C7	EC557190	7-16	ER563354	15-R3	EZ654208	7-34x	MZ314605	5-21
EC251122	14-C2	EC558202	10-C25	ER573524	15-R5	EZ655198	7-35x	MZ314998	5-14
EC251122	14-C5	EC558235	10-C26	ER593346	14-R20	EX655942	18-26	MZ317406	5-19x
EC251291	14-C1	EC565345	15-C3	ER641261	15-R4	HA533597	1-21	MZ402377	8-73x
EC290520	9-C3	EC593763	7-10	ES250064	8-72x	HA533608	1024	MZ576538	3-9x
EC290520	9-C5	EC641136	7-14x	ES389700	8-15	HE563220	1-25	MZ580061	8-88
EC290520	9-C16	EC646031	15-C10	ES422436	8-40	HP536501	1-19	MZ580500	6-19
EC290520	10-C1	EC650968	7-25x	ES479485	7-43	HR384513	1-22	MZ580577	609
EC290520	10-C4	EC661882	7-11x	ES479485	8-41	HZ532710	1-7	MZ580601	7-46x
EC290520	10-C15	ED219464	9-D2	ES479496	8-38	HZ532732	1-13	MZ580680	6-27
EC290520	11-C14	ED219464	11-D1	ES550001	12-SW1	HZ532765	1-15	MZ580781	8-3
EC311793	14-C7	ED219464	11-D5	ES563387	8-37	HZ532776	1-16	MZ581275	8-10
EC313121	11-C7	ED224548	14-D2to5	ES573456	5-25	HZ643544	1-2	MZ582030	8-64
EC313121	15-C6	ED357794	15-D10	ES573456	6-29	HZ645298	1-3	MZ582120	8-84
EC320040	11-C13	ED491130	11-D2	ES573671	18-15x	HZ803597	1-4	MZ583198	7-36x
EC320051	9-C7	ED494583	13-D4	ES640541	16-SW3	MB527556	8-92	MZ597093	4-5
EC320051	E9-C17	ED498150	13-D11	ES640552	17-SW2	MB580138	8-71	MZ597126	4-16x
EC320051	9-C20	ED511097	15-D6to9	ES641068	8-43x	MB606712	8-48	MZ597644	2-8
EC320051	10-C8	ED557447	14-D1	ES641283	18-8	MB665561	4-8	MZ597690	2-9

INDEX

Parts No.	Ref. No. & Symbol No.	Parts No.	Ref. No. & Symbol No.	Parts No.	Ref. No. & Symbol No.	Parts No.	Ref. No. & Symbol No.	Parts No.	Ref. No. & Symbol No.
MZ598263	19-7x	GZ580511	6-12	ZW260278	3-4				
MZ605283	8-16	ZG580522	6-18	ZW270088	3-19				
MZ636985	8-75	ZG580533	6-16	ZW270088	5-8				
MZ640383	8-21	ZG580770	8-80	ZW270088	8-6x				
MZ640405	18-3x	ZG582131	8-78	ZW270088	8-89				
MZ640440	18-38x	ZG586427	5-11	ZW270101	9-14x				
MZ640574	18-20x	ZG659608	6-20	ZW270123	8-90				
MZ640585	18-21x	ZS200384	6-26	ZW270156	3-5				
MZ640618	17-2	ZS200610	19-39x	ZW270156	6-11				
MZ640664	4-25	ZS243516	8-79	ZW273745	1-10x				
MZ640675	8-18	ZS312221	19-66x	ZW273756	6-14				
MZ640787	19-19	ZS323728	5-10	ZW273756	14-3				
MZ640798	19-20x	ZS323728	6-22	ZW273802	8-26x				
MZ640800	19-6x	ZS323728	8-11	ZW273802	16-5				
MZ640877	19-46x	ZS323728	19-15x	ZW273835	1-9				
MZ640945	18-7	ZS325495	7-12	ZW273881	1-28				
MZ643375	4-2	ZS325495	8-22x	ZW273881	7-27x				
MZ643408	4-7	ZS325495	15-3	ZW273881	18-25x				
MZ643443	8-63x	ZS325495	18-2	ZW273892	7-7x				
MZ643454	8-85	ZS325495	18-19x	ZW273892	7-30x				
MZ643465	8-87	ZS325495	19-43x	ZW273914	1-12				
MZ643498	5-2	ZS327835	7-45x	ZW273914	7-9x				
MZ643522	8-36	ZS355511	1-27	ZW290283	5-17				
MZ643858	4-21	ZS355522	7-41x	ZW290283	6-28				
MZ650046	2-7	ZS379350	7-24x	ZW290283	8-70				
MZ659632	18-11x	ZS379350	7-37x	ZW318014	19-30x				
MZ802980	8-7	ZS379350	8-58	ZW324281	19-51x				
MZ810191	6-23x	ZS379350	16-3	ZW345442	8-4				
MZ810191	8-45	ZS379350	18-9	ZW397146	5-26				
SA428714	19-50x	ZS379405	5-22	ZW403200	8-86				
SA640934	19-38	ZS392141	19-68x	ZW410051	6-17				
SB640732	8-30x	ZS394525	1-20	ZW413188	7-8x				
SB640743	8-31x	ZS396000	1-17	ZW413188	7-29x				
SB643500	8-28x	ZS411660	4-22	ZW413256	1-18				
SB643577	8-29	ZS411660	19-59x	ZW413278	8-61x				
SC640991	19-1	ZS413155	6-31	ZW416698	8-13				
SC643724	19-2	ZS413166	5-20x	ZW419646	19-52x				
SE581602	19-21	ZS413201	7-6x	ZW420682	8-77				
SE612055	19-31	ZS413201	8-47x	ZW420682	19-13x				
SE613866	19-34x	ZS413234	2-11	ZW430402	8-95				
SE613888	19-13x	ZS413785	3-18	ZW499593	19-10x				
SE626951	19-23	ZS417137	5-15	ZW510827	7-5				
SE627120	19-67x	ZS417150	7-28x	ZW516611	7-50x				
SE631102	19-28	ZS417150	19-47x	ZW516611	8-27				
SE639696	19-23x	ZS417216	4-14	ZW516611	16-4				
SE640754	19-18	ZS417216	8-99	ZW516611	18-13x				
SK597633	2-4	ZS421806	7-49x	ZW516993	15-6				
SK634410	19-57	ZS421806	14-2	ZW535094	4-20				
SK638976	8-100	ZS421806	15-5	ZW535094	6-25				
SK638976	19-56	ZS422076	5-5x	ZW550642	6-21				
SK640901	19-63	ZS422076	5-24	ZW556828	4-13				
SK640912	19-61	ZS422076	7-44x	ZW562476	3-20x				
SK640923	19-62	ZS422076	8-98	ZW575730	19-22x				
SK645300	19-64	ZS422076	14-5	ZW575763	6-4				
SM640956	19-4	ZS422076	18-4	ZW575774	6-15				
SM640967	19-5x	ZS422076	18-16x	ZW580173	8-76				
SP641002	19-26	ZS432674	19-49x	ZW580498	6-3				
SP641013	19-27x	ZS432843	17-3	ZW580678	6-13				
SP641024	19-41x	ZS435273	3-21	ZW597543	2-2				
SP641035	19-42x	ZS460438	1-23x	ZW597622	2-3				
SP641046	19-44x	ZS462947	18-24x	ZW603764	2-14x				
SP641057	19-45x	ZS481724	4-11x	ZW603775	2-15x				
SP641237	19-17	ZS483502	8-74x	ZW603786	2-12				
SZ480712	19-40x	ZS499331	4-6	ZW603797	2-13x				
SZ529920	19-48x	ZS508354	6-30	ZW603990	4-4				
SZ534543	19-3x	ZS533766	8-97	ZW648685	8-96				
SZ597420	19-21x	ZS537006	1-5	ZW655953	4-17x				
TC387617	6-8x	ZS562432	1-14	ZW664841	8-60x				
TC494267	19-35x	ZS575392	19-29x						
ZG249107	19-9x	ZS593796	4-19						
ZG290878	18-12x	ZS608354	5-27						
ZG315011	8-91	ZS609298	8-25x						
ZG317496	3-12	ZS613901	19-65						
ZG428927	8-8	ZS664345	19-54x						
ZG456120	8-20	ZS665550	19-53x						
ZG466312	1-8	ZW235585	4-24						
ZG535105	4-9	ZW259738	8-69						
ZG540090	5-23	ZW259773	8-67						
ZG540090	8-93x	ZW260010	4-12						
ZG540617	3-16	ZW260256	6-5						

LEFT

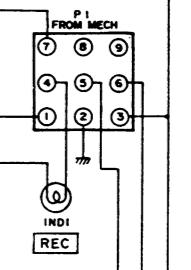
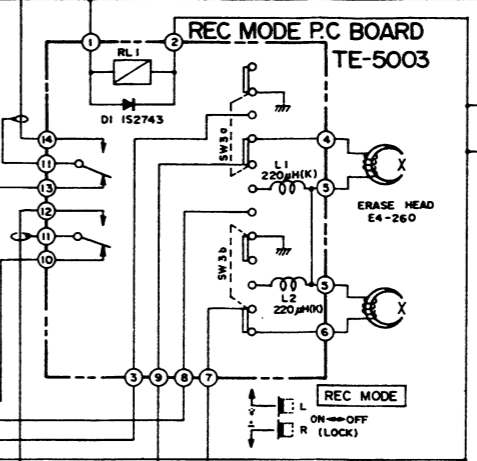
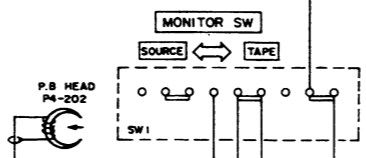
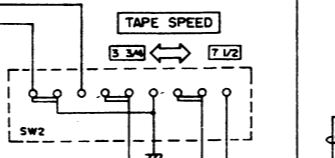
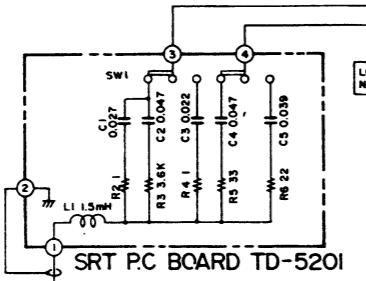

REC AMP P.C BOARD MY-5016(3ED)

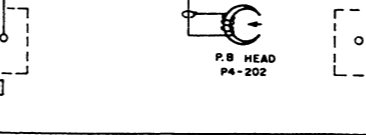
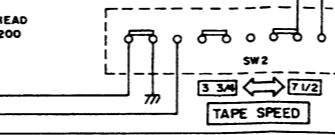
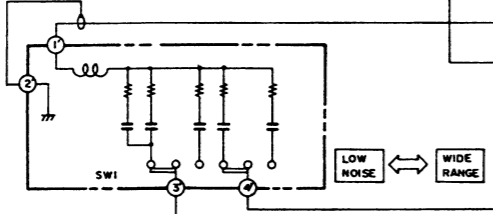
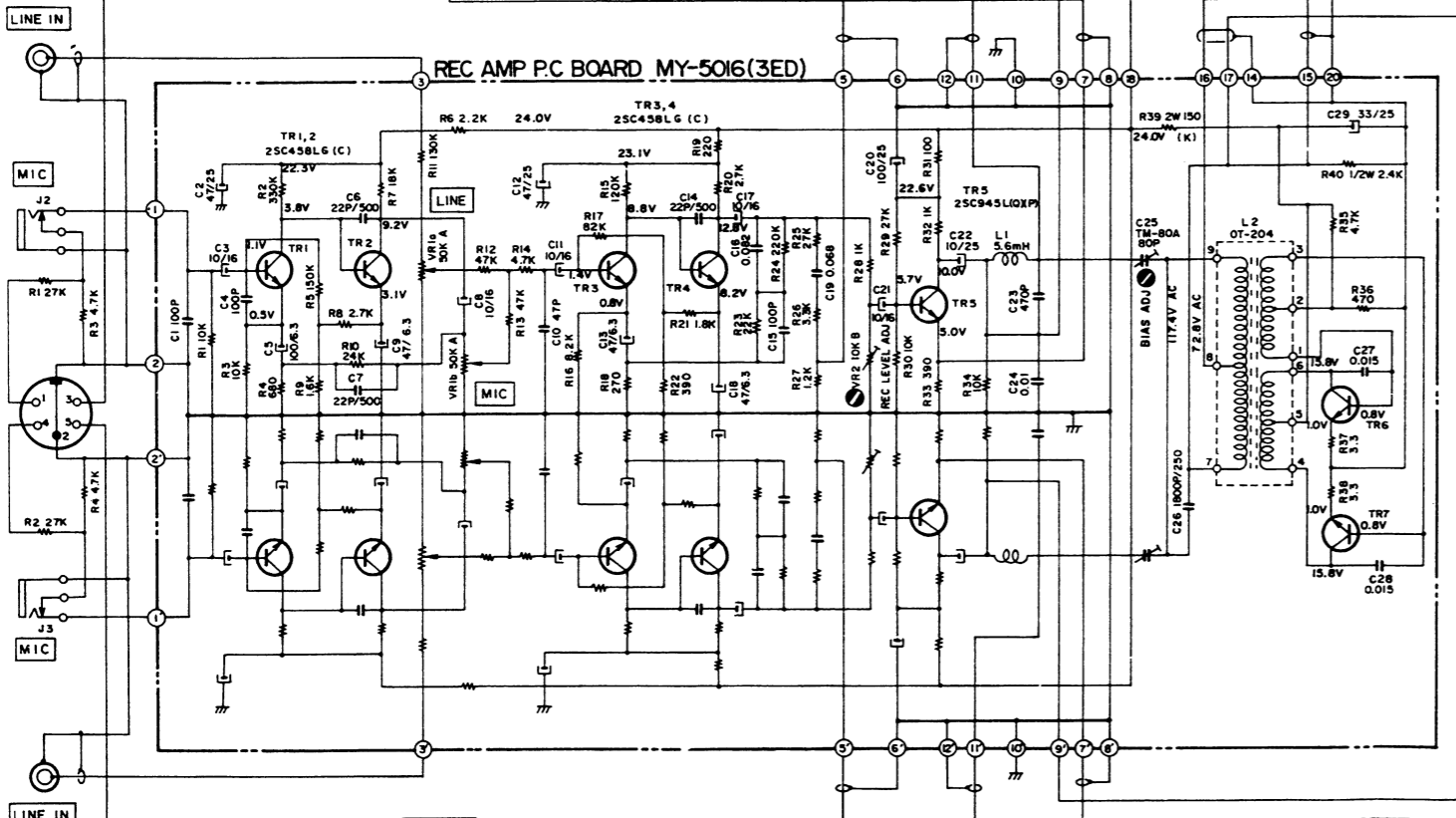

PB AMP P.C BOARD MY-5017(2ED)

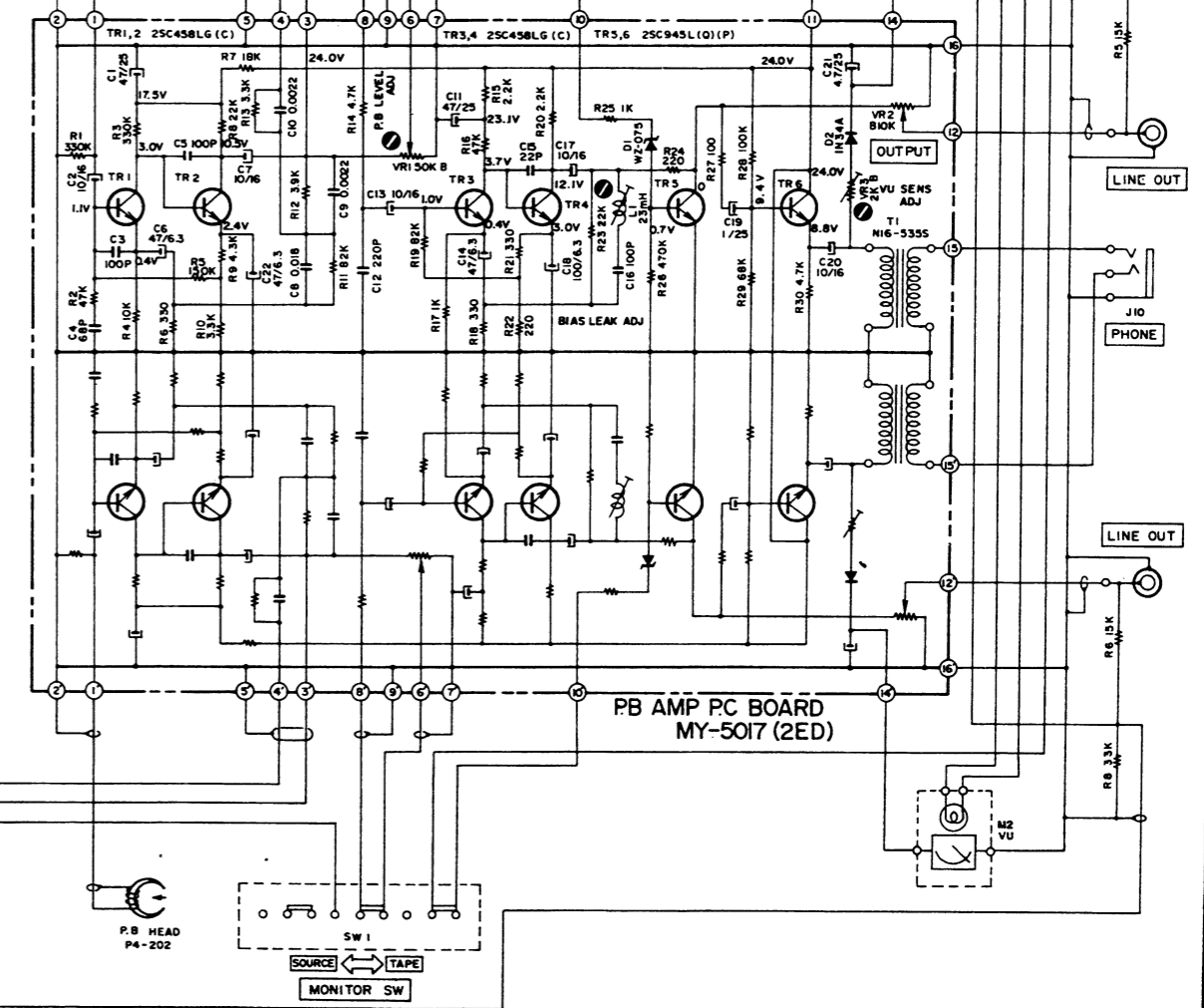

NOTE
UNLESS OTHERWISE SPECIFIED
ALL RESISTORS IN Ω 1/4W(J)
ALL CAPACITORS IN μF 50V(V)

GX-630D
SCHEMATIC DIAGRAM
NO. 5-1 1501636A

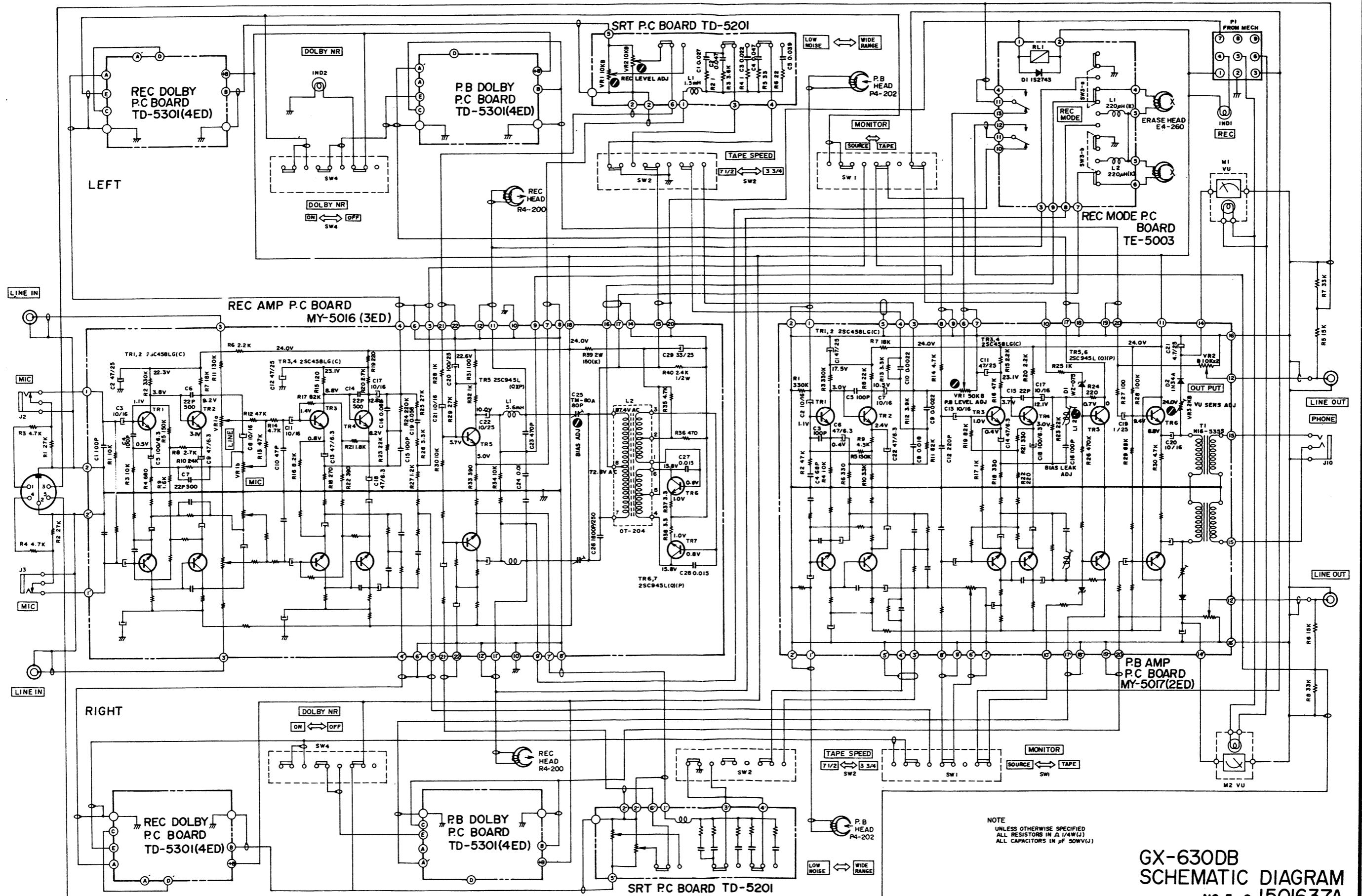

GX-630DB
 SCHEMATIC DIAGRAM
 No. 5-2 1501637A

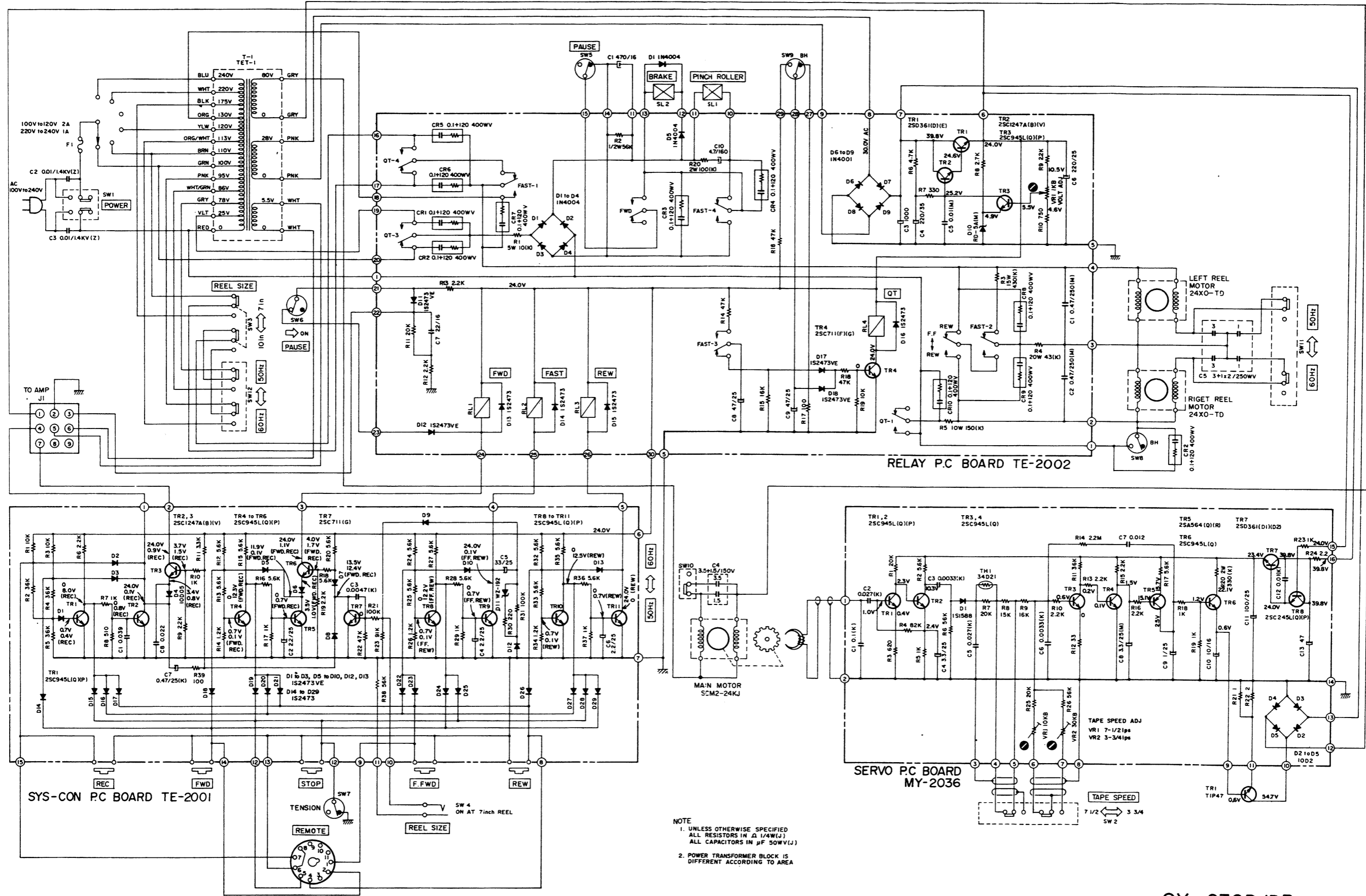

NOTE
 1. UNLESS OTHERWISE SPECIFIED ALL RESISTORS IN Ω 1/4W(L) ALL CAPACITORS IN μ F 50WV(J)
 2. POWER TRANSFORMER BLOCK IS DIFFERENT ACCORDING TO AREA

GX-630D/DB
 SCHEMATIC DIAGRAM
 No. 5-3 1501638A

GX-630DB

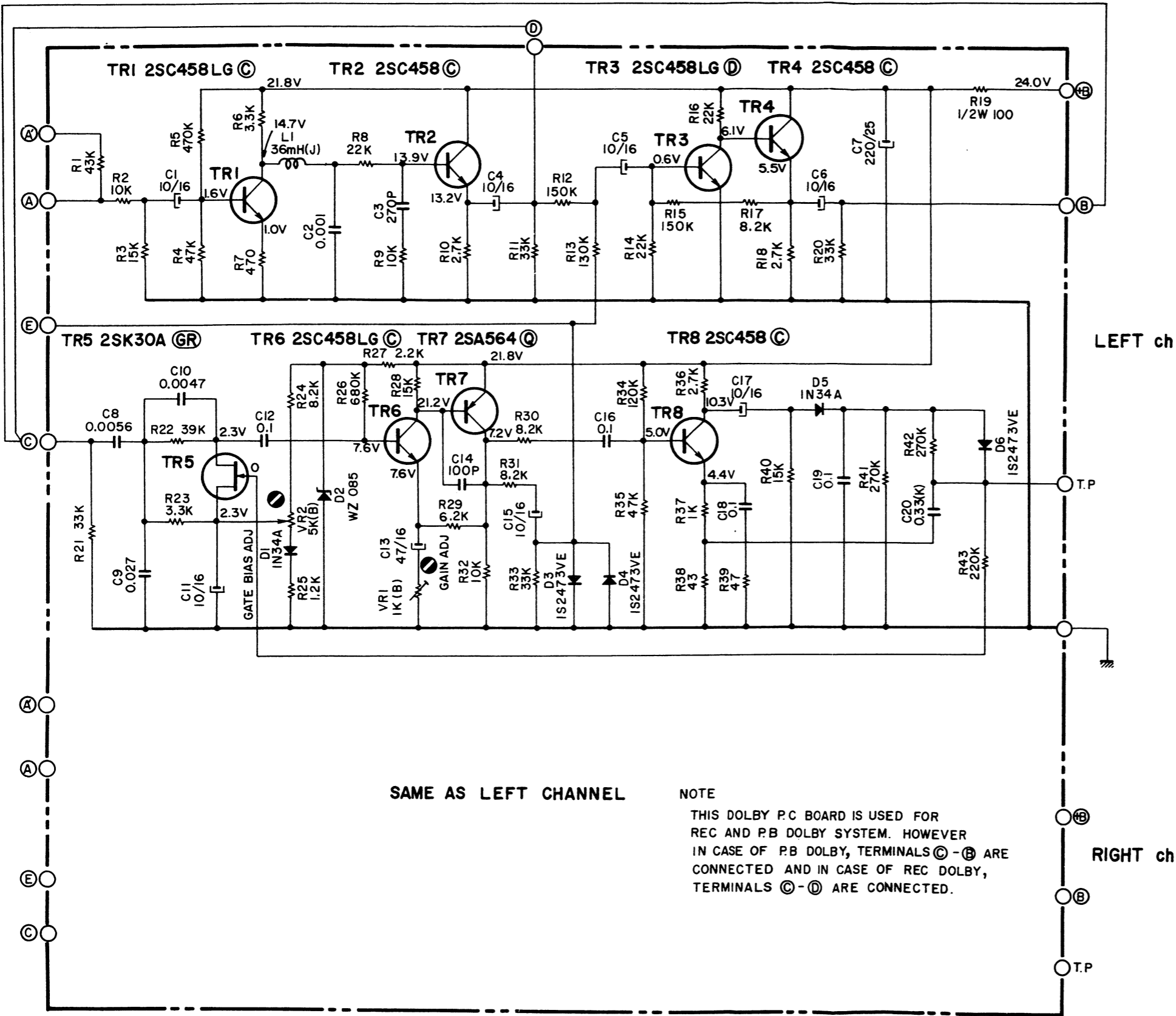

SAME AS LEFT CHANNEL

NOTE
 THIS DOLBY P.C BOARD IS USED FOR
 REC AND P.B DOLBY SYSTEM. HOWEVER
 IN CASE OF P.B DOLBY, TERMINALS (C)-(B) ARE
 CONNECTED AND IN CASE OF REC DOLBY,
 TERMINALS (C)-(D) ARE CONNECTED.

NOTE
 UNLESS OTHERWISE SPECIFIED
 ALL RESISTORS IN Ω 1/4W(J)
 ALL CAPACITORS IN μ F 50WV(J)

DOLBY P.C BOARD TD-5301 4ED

GX-630DB
 SCHEMATIC DIAGRAM
 NO.5-4 1501639A

GX-630D/DB

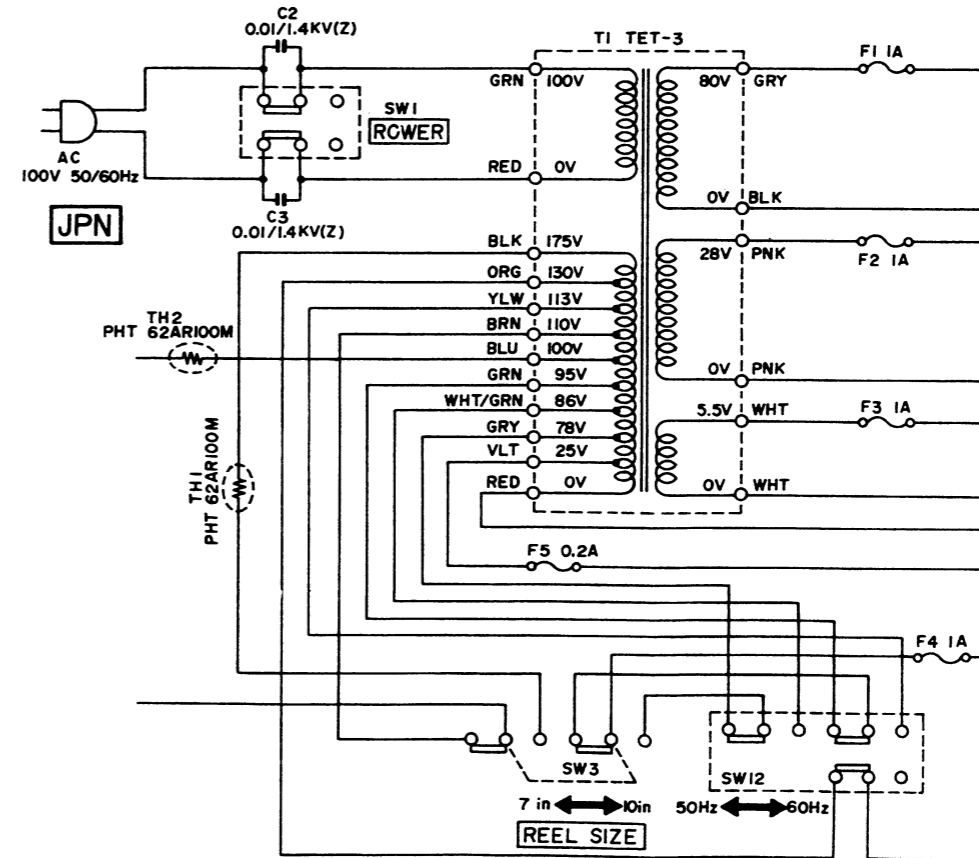
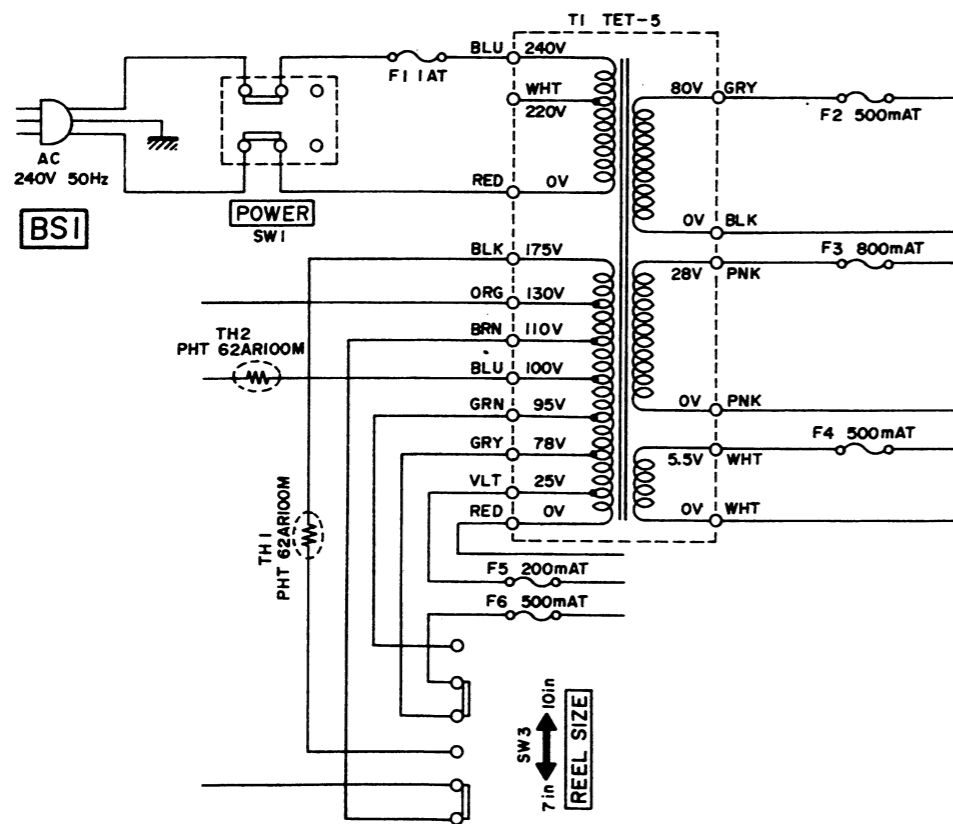
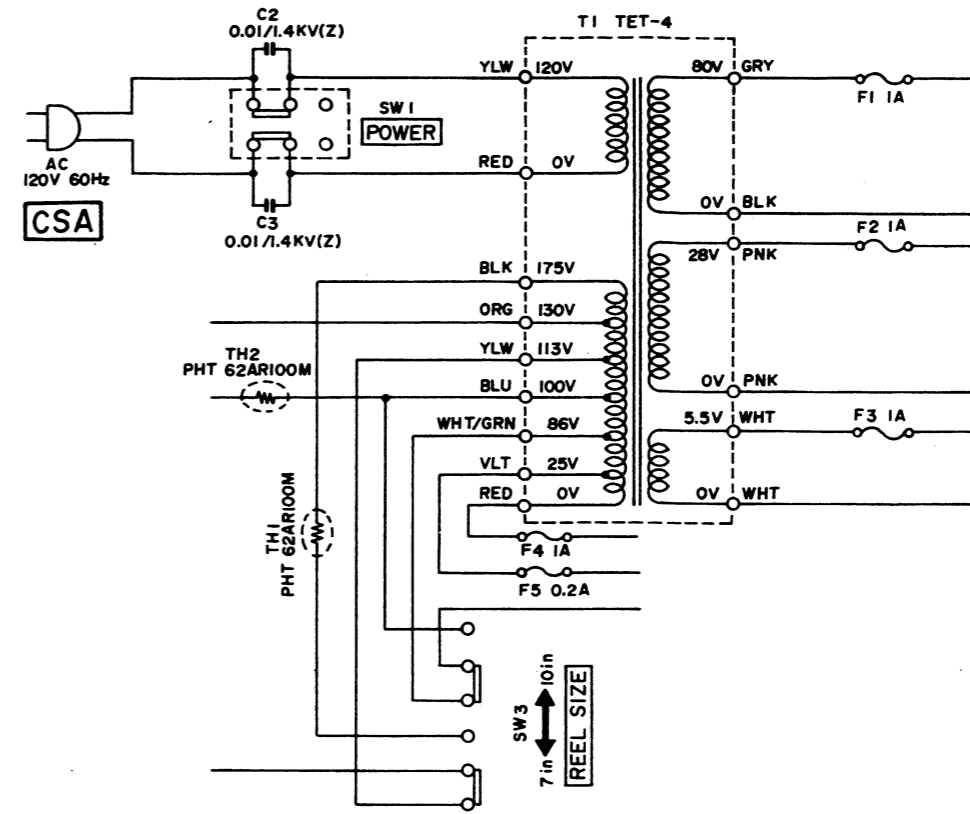
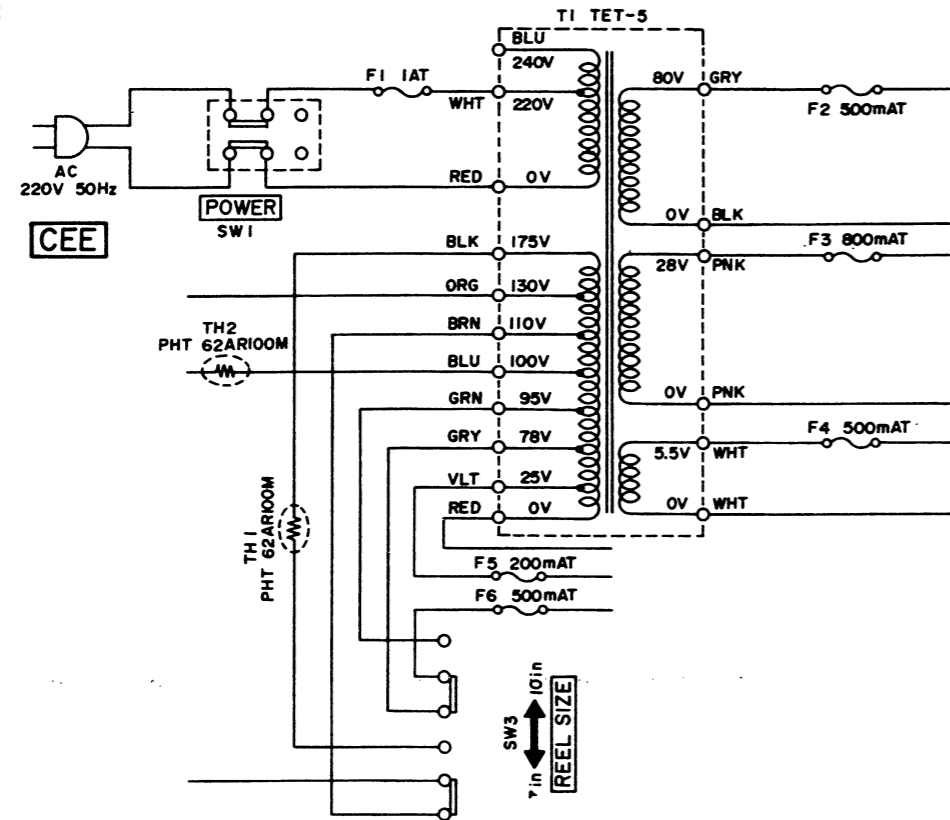

GX-630D/DB SCHEMATIC DIAGRAM
No. 5-5 1501640A